

DOUBLE-EFFECT STEAM-FIRED ABSORPTION CHILLERS



SUPER ABSORPTION

COOLING

16NK

Nominal cooling capacity 345 to 4652 kW

Eighteen sizes with nominal cooling capacities from 345 to 4652 kW.

The 16NK absorption chillers are designed for cooling applications where low-pressure steam is available as waste heat.

Minimises global warming effect by greatly reducing power consumption and eliminating the generation of greenhouse gases.

Allows diversification of critical cooling requirements. Critical cooling loads are met with minimal electrical power input.

Allows use of smaller emergency generators since the electrical load associated with an absorption chiller is minimal.

PHYSICAL DATA

16NK		11	12	13	21	22	31	32	41	42
Cooling capacity	kW	345	447	549	689	861	1034	1238	1378	1551
Chilled water system*										
Flow rate	l/s	14.8	19.2	23.6	29.7	37.2	44.4	53.3	59.4	66.7
Pressure drop	kPa	44	64	64	57	42	41	49	46	41
Connection (ANSI)	in	4	4	4	5	6	6	6	8	8
Retention volume	m ³	0.13	0.15	0.17	0.24	0.28	0.34	0.36	0.46	0.48
Cooling water system*										
Flow rate	l/s	24.7	31.9	39.4	49.4	61.9	74.2	88.9	98.9	111.4
Pressure drop	kPa	68	40	49	109	74	53	65	67	73
Connection (ANSI)	in	5	5	5	6	8	8	8	10	10
Retention volume	m ³	0.34	0.38	0.42	0.58	0.63	0.89	0.95	1.11	1.9
Steam system Saturated steam 784 kPa										
Consumption	kg/h	400	510	630	790	980	1180	1410	1570	1770
Dimensions mm										
Length A		2810	3850	3850	3880	4920	5040	5040	5100	5100
Height B		2200	2200	2200	2250	2250	2390	2390	2600	2600
Width C		2050	1910	1910	2240	2070	2170	2170	2400	2400
Operating weight	kg	4600	5800	6100	7500	8800	11200	11800	13900	14500
Power supply V-ph-Hz 400-3-50										
Total current drawn	A	10.8	10.8	10.8	13.3	13.3	13.6	13.6	20.7	20.7

16NK		51	52	53	61	62	63	71	72	81
Cooling capacity	kW	1723	1927	2170	2412	2757	3101	3446	3963	4652
Chilled water system*										
Flow rate	l/s	74.2	83.1	93.9	103.9	118.6	133.6	148.3	170.6	200.3
Pressure drop	kPa	98	46	61	123	83	78	54	81	84
Connection (ANSI)	in	8	8	8	10	10	10	12	12	14
Retention volume	m ³	0.65	0.71	0.77	0.99	1.06	1.13	1.41	1.61	1.94
Cooling water system*										
Flow rate	l/s	123.6	138.3	155.6	173.1	197.8	222.5	247.2	284.4	333.9
Pressure drop	kPa	53	71	94	61	83	111	77	113	122
Connection (ANSI)	in	12	12	12	14	14	14	16	16	16
Retention volume	m ³	1.87	2.01	2.14	2.79	2.97	3.15	3.67	4.11	4.76
Steam system Saturated steam 784 kPa										
Consumption	kg/h	1960	2200	2470	2750	3140	3530	3920	4510	5300
Dimensions mm										
Length A		5330	5870	6370	6100	6190	6710	6440	7460	7460
Height B		2900	2900	2900	3330	3330	3330	3450	3450	3650
Width C		2770	2800	2800	2970	3000	3000	3300	3300	3500
Operating weight	kg	18800	20800	22300	26500	30000	32100	38000	42300	47300
Power supply V-ph-Hz 400-3-50										
Total current drawn	A	22.7	24.5	24.5	25.5	25	25	33.5	33.5	33.5

Cooling per ARI 560 2000:

* 12.2 → 6.7°C (fouling factor = 0.0176 m² K/kW)

** 29.4 → 35.4°C (fouling factor = 0.044 m² K/kW)

FEATURES AND ADVANTAGES

- Eighteen sizes with nominal cooling capacities from 345 to 4652 kW.
- The 16NK absorption chillers are designed for cooling applications where low-pressure steam is available as waste heat.
- Can tie into district steam systems.
- Allows diversification of critical cooling requirements. Critical cooling loads are met with minimal electrical power input.
- Allows use of smaller emergency generators since the electrical load associated with an absorption chiller is minimal.
- Environmentally balanced and CFC-free.
- Minimises global warming effect by greatly reducing power consumption and eliminating the generation of greenhouse gases.
- Reduced noise and vibration levels. The absorption chiller does not use a large motor-compressor, leading to quiet, vibration-free operation.
- Small footprint. The high efficiency associated with double-effect chillers results in a reduction of the required installation space.
- Auto-diagnosis system monitors operating conditions, predicts chiller information and maintains stable operation.
- Advanced high-precision control system.
- Absorption pump with inverter control for efficient, energy-saving operation.
- High-performance purge system minimises maintenance requirements.
- State-of-the-art protection devices guarantee enhanced operating safety.

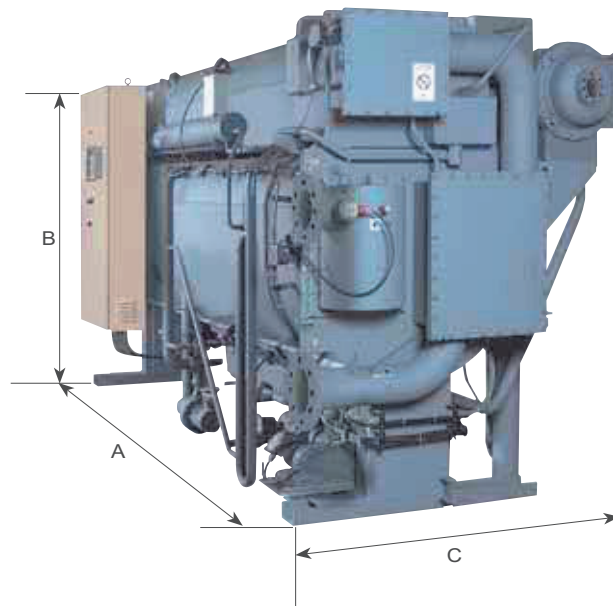

CONTROLS

Display and control board

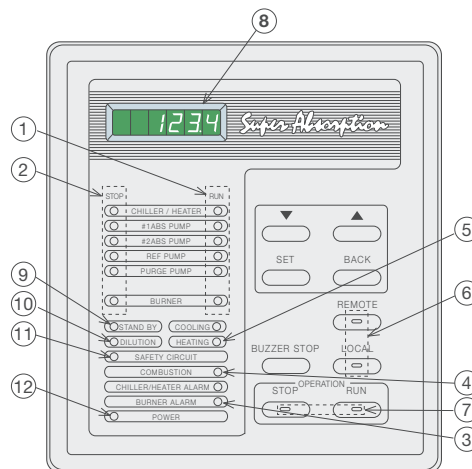

- | | |
|------------------------------|------------------------------|
| 1 Operation indication | 7 Operation mode selection |
| 2 Stop indication | 8 Data display |
| 3 Alarm indication | 9 Stand-by indication |
| 4 Combustion indication | 10 Dilution indication |
| 5 Cooling/heating indication | 11 Safety circuit indication |
| 6 Remote/local select button | 12 Power indication |