

NEW

**WATER CHILLERS
HEAT PUMPS**



- Energy excellence
- Compact and reliable
- Twin-turbine centrifugal compressors
- Oil-Free compressors
- Flooded shell and tubes evaporator
- Self-adjusting electronic control
- Touch screen control interface

COOLING

19PV

AQUAEDGE.

Cooling capacity 550-1600 kW
Heating capacity 650-1875 kW

The latest generation of **19PV** water chillers and water-to-water heat pumps are the perfect solution for all heating and cooling applications in the Office, Healthcare, Industry, Administration, Shopping centers, data centers and Collective Housing markets.

19PV is optimised to use non-ozone depleting HFC R134a refrigerant.

This range guarantees compliance with the most demanding requirements for high energy efficiency and CO₂ reduction to comply with the various applicable European directives and regulations.

When producing chilled water, these units can be connected to a drycooler or a water cooling tower.

With the heat pump option, the units can produce hot water for heating applications. They can also be used in cooling mode by reversing the cycle on the hydraulic circuits using a set of valves (hydraulic valves not supplied).



CARRIER participates in the ECP programme for LCP/HP
Check ongoing validity of certificate:
www.eurovent-certification.com

DESCRIPTION

■ 19PV, series

Very High Efficiency cooling or heating version

The product is optimised to meet the most demanding technical and economic requirements.

The product is optimised for very high energy efficiency applications for which optimum seasonal performance SEER values are required, ensuring operating costs are kept to a minimum.

19PV units are packaged machines supplied as standard with the following components:

- Maglev centrifugal semi-hermetic compressors
- No oil
- Shell and tube type chilled-water evaporator
- Shell and tube type hot water condenser
- Electrical power and remote control cabinet:
 - 400 V-3ph-50 Hz general power supply (+/-10%) + Earth
 - transformer fitted as standard on the machine for supplying the remote control circuit with 24 V
- Touch'Pilot electronic control module
- Casing for indoor installation

The entire 19PV range complies with the following EC directives and standards:

- Machinery Directive 2006/42/EC
- Electromagnetic Compatibility Directive 2014/30/EU
- EMC immunity and emissions EN 61800-3 'C2'
- Low Voltage Directive 2014/35/EU
- RoHS 2011/65/EU
- Pressure Equipment Directive (PED) 2014/68/EU
- Machinery Directive EN 60-204 -1
- Refrigeration systems and heat pumps EN 378-2.
- Regulation (EU) 2016/2281 implementing Directive 2009/125/EC with regard to ecodesign requirements

DESIGNATION

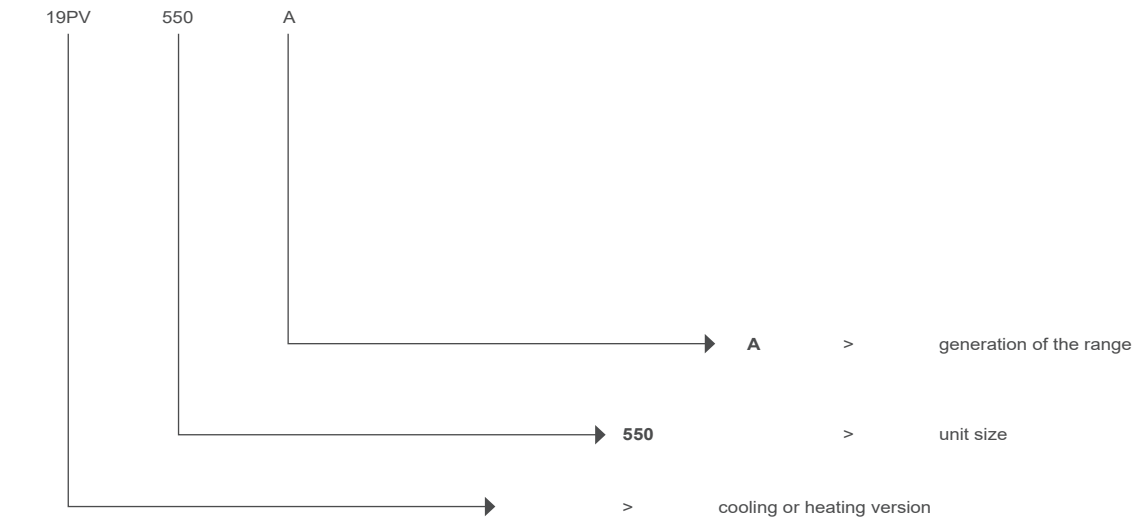

TECHNICAL INSIGHTS

Twin-turbine centrifugal compressors,

- 2 Stages centrifugal compressors
- Optimized for R134a refrigerant
- Oil-free type
- Noiseless, vibration less via Magnetic levitation
- Compression ratio: from 1.5 to 5.0
- High efficiency permanent-magnet synchronous inverter motor.
- Linear step less capacity control via integrated inverter motor (up to 36000 rpm)
- Compressor equipped with Inlet Guide Valve at the turbine suction
- Compressor capacity control by successive use of speed variation swept volume variation at the turbine
- Integrated Soft- Start system (starting current limited to 5A)
- High Power Factor motor ($\cos\phi > 0.9$ for main operating conditions)
- Motor and electronic power section cooled by refrigerant
- Full electronic protection of motor against thermal and electrical overload via Internal sensors
- Rotation direction, no phase, under voltage, over voltage and power failure control
- Sensor on refrigerant suction and discharge for temperature monitoring
- Degree of protection: IP54

Shell and tube evaporator

- High performance glandless technology
- Copper tube bundle with internal and external grooves
- 19 mm thermal insulation
- Victaulic type coupling
- Maximum pressure, water side, of 10 bar.

Shell and tube condenser

- Copper tube bundle with internal and external grooves
- 19 mm thermal insulation (option)
- Built-in oil separator
- Victaulic type coupling
- Maximum pressure, water side, of 10 bar.

Refrigerant accessories

- Dehumidifier filters with rechargeable cartridges
- Hygroscopic sight glasses
- Electronic expansion valves
- Check-valve to prevent fluid recirculation in the compressor during transition phase

Regulation and safety instruments

- High and low pressure sensors
- Safety relief valves on refrigerating circuit
- High pressure switch on each compressor
- Evaporator antifreeze protection sensor
- Chilled water and hot water control sensors
- Electronic evaporator water circulation controller

Electrical cabinet

- Electrical cabinet index of protection IP23
- Safety disconnect switch
- 24 V control circuit
- Remote control transformer circuit
- Protection of the power and control circuits
- Touch'Pilot microprocessor-controlled electronic control module
- Electrical cabinet wire numbers
- Location of main components
- EMC filters and line reactors
- Door contact protection

Touch'Pilot control module

- User interface with 7 inch touchscreen
- Intuitive, user-friendly navigation using icons
- Clear information display in 10 languages (English, Spanish, French, German, Dutch, Turkish, Italian, Portuguese, Russian +1 Free)



The electronic control module performs the following main functions:

- regulation of the chilled water temperature (at the return or at the outlet)
- regulation of the water temperature based on the outdoor temperature (water law)
- regulation for low temperature energy storage
- second set-point management
- complete management of compressors with start-up sequence, timer and operating time balancing
- self-regulating and proactive functions with adjustment of settings on drift control
- continuous power control slide system on the compressors according to the thermal requirements
- management of compressor short cycle protection
- phase reversal protection
- management of occupied/unoccupied modes (according to the time schedule)
- equalisation of compressor operating hours
- condensing temperature limitation (Option 152)
- diagnosis of fault and operating statuses
- management of a fault memory allowing a log of the last 50 incidents to be accessed, with operating readings taken when the fault occurs
- blackbox memory
- master/slave management of two machines with equalisation of operating hours and automatic switching in case of a machine fault
- weekly and hourly time schedule for the machine, including 16 periods of absence
- display of all machine parameters (3 access levels, User/Maintenance/Factory, password-protected): temperature, set-points, pressures, flow rate, operation time.
- display of trend curves for the main values
- storage of maintenance manual, wiring diagram and spare parts list.

Unit construction

- Electrical cabinet in light grey (RAL 7035)

TECHNICAL INSIGHTS

Remote management

Touch'Pilot is equipped as standard with an ETHERNET (IP) connection, offering a range of options for remote management, monitoring and diagnostics.

Using the integrated Webserver, a simple internet connection uses the unit's IP address to access the Touch'Pilot interface on the PC, facilitating everyday management tasks and maintenance operations.

Numerous communication protocols are available: MODBUS/JBUS TC/IP as standard, BACNET IP optional, enabling integration with most CMS/BMS

Several contacts are available as standard, enabling the machine to be controlled remotely by wired link:

- automatic operation control: when this contact is open, the machine stops
- set-point 1/set-point 2 selector: when this contact is closed, a second cooling set-point is activated (energy storage or unoccupied mode, for example)
- heating/cooling operating mode selection
- fault reporting: this contact indicates the presence of a major fault which has caused one or both refrigerating circuits to stop
- operational status reporting indicates that the unit is in production mode
- Condenser flow switch
- set-point adjustable via 4-20 mA signal: this input is used to adjust the active set-point.
- power limitation adjustable by 4-20 mA signal
- power indication: analogue output (0-10 V) providing an indication of the unit's load rate.
- user fault reporting enables integration of a fault in the water loop
- general fault reporting: this contact indicates that the unit has stopped completely
- User interlock (open=unit shuts down / closed = enable to operate)
- alert reporting: this contact indicates the presence of a minor fault which has not caused the circuit affected to stop.
- end of storage signal: enables return to the second set-point at the end of the storage cycle
- schedule override: closing this contact cancels the time schedule.
- Evaporator pump control (control by 0-10V command)

Direct access to technical literature

- Instruction manual
- Electrical diagram
- Spare parts list



Web server integrate
as standard

IP address



Remote management via web server
Connection to RJ port
Connection via IP address
All the HMI functionalities available on the PC
Simplified remote monitoring



E-mail alerts
(2 addresses)

Maintenance alert as standard

Touch'Pilot has two maintenance reminder functions as standard, making users aware of the need to regularly perform maintenance operations and to guarantee the service life and performance of the unit. These two functions can be activated independently.

A reminder message appears on the unit's HMI screen, and stays there until it is acknowledged by the maintenance operator. The information and alert relating to these functions are available on the communication bus to be used on the CMS/BMS.

- the scheduled maintenance reminder: when activated, this function enables the period between two maintenance inspections to be set. This period may be set by the operator in either days, months or operating hours, depending on the application.
- the compulsory F-GAS sealing test maintenance reminder: when activated, this function, which is the default factory setting, enables the period between two sealing tests to be selected, according to the refrigerant charge, in compliance with the F-GAS regulations.

OPTIONS

Option	No.	Description	Advantage	Use 19PV
Low noise level	15	Discharge piping acoustic insulation	Up to 3 dB(A) quieter than standard unit	0550-1600
Master/slave operation	58A	Unit equipped with supplementary water outlet temperature sensor kit (to be field installed) allowing master/slave operation of two units connected in parallel over Ethernet network (IP)	Optimised operation of two units connected in parallel operation with operating time equalisation	0550-1600
Single power connection point	81	Unit power connection via one main supply connection	Quick and easy installation	0900-1600
Evap. single pump power/control circuit	84	Unit equipped with an electrical power and control circuit for one pump evaporator side	Quick and easy installation: the control of fixed speed pumps is embedded in the unit control	0550-1180
Cond. single pump power/control circuit	84R	Unit equipped with an electrical power and control circuit for one pump condenser side	Quick and easy installation: the control of fixed speed pumps is embedded in the unit control	0550-1180
Condenser insulation	86	Thermal condenser insulation	Minimizes thermal dispersions condenser side (key option for heat pump or heat recovery applications)	0550-1600
Service valve set	92	Liquid line valve (evaporator inlet) and compressor suction line valve	Allow isolation of various refrigerant circuit components for simplified service and maintenance	0550-1600
Evaporator with one pass less	100C	Evaporator with one pass on the water side. Evaporator inlet and outlet on opposite sides.	Easy to install, depending on site. Reduced pressure drops	0550-1600
Condenser with one pass less	102C	Condenser with one pass on the water side. Condenser inlet and outlet on opposite sides.	Easy to install, depending on site. Reduced pressure drops	0550-1600
Reversed evaporator water connections	107	Evaporator with reversed water inlet/outlet	Easy installation on sites with specific requirements	0550-1600
Reversed condenser water connections	107A	Condenser with reversed water inlet/outlet	Easy installation on sites with specific requirements	0550-1600
Bacnet over IP	149	Bi-directional high-speed communication using BACnet protocol over Ethernet network (IP)	Easy and high-speed connection by ethernet line to a building management system. Allows access to multiple unit parameters	0550-1600
Control for low cond. temperature	152	Output signal (0-10 V) to control the condenser water inlet valve	Simple installation: for applications with cold water at condenser inlet (ex. ground-source, groundwater-source, superficial water-source applications) the signal permits to control a 2 or 3-way valve to maintain condenser water temperature (and so condenser)	0550-1600
Dry-cooler control	154	Remote control of 09PE or 09VE dry-cooler based on a 0-10V signal. The 09PE or 09VE dry-cooler shall be selected with control cabinet option	Easy system management, extended control capabilities of a remote dry-cooler	0550-1600
Input contact for Refrigerant leak detection	159	0-10 V signal to report any refrigerant leakage in the unit directly on the controller (the leak detector itself must be supplied by the customer)	Immediate customer notification of refrigerant losses to the atmosphere, allowing timely corrective actions	0550-1600
Compliance with Swiss regulations	197	Additional tests on the water heat exchangers: supply (additional of PED documents) supplementary certificates and test certifications	Conformance with Swiss regulations	0550-1600
Compliance with Russian regulations	199	EAC certification	Conformance with Russian regulations	0550-1600
Welded evaporator connection kit	266	Victaulic piping connections with welded joints	Easy installation	0550-1600
Welded condenser water connection kit	267	Victaulic piping connections with welded joints	Easy installation	0550-1600
Flanged evaporator water connection kit	268	Victaulic piping connections with flanged joints	Easy installation	0550-1600
Flanged condenser water connection kit	269	Victaulic piping connections with flanged joints	Easy installation	0550-1600
230V electrical plug	284	230V AC power supply source provided with plug socket and transformer (180 VA, 0,8 Amps)	Permits connection of a laptop or an electrical device during unit commissioning or servicing	0550-1600
Free-cooling dry-cooler control	313	Remote control of 09PE or 09VE dry-cooler based on a 0-10V signal. The 09PE or 09VE dry-cooler shall be selected with control cabinet option	Easy system management, extended control capabilities of a remote dry-cooler used in free-cooling mode	0550-1600
Heat Pump application	322	Unit configured for Heat Pump application, includes thermal condenser insulation	Optimisation on heating mode & minimize thermal dispersions condenser side	0550-1600

PHYSICAL DATA, STANDARD UNITS

19PV			550	720	800	900	1010	1180	1300	1450	1600	
Heating												
Standard unit	HW1	Nominal capacity	kW	649	844	939	1050	1198	1389	1538	1700	1875
		COP	kW/kW	6,13	6,26	5,93	5,79	5,89	5,76	5,97	5,89	5,67
Full load performances*	HW2	Nominal capacity	kW	629	817	915	1039	1186	1351	1491	1648	1820
		COP	kW/kW	4,89	4,81	4,63	4,68	4,68	4,53	4,72	4,62	4,50
Seasonal energy efficiency**	HW1	SCOP _{30/35°C}	kW/kW	7,43	7,42	7,35	7,30	7,23	6,82	6,90	6,47	6,54
		η _s heat _{30/35°C}	%	289	289	286	284	281	265	268	251	254
		P _{rated}	kW	762,9	992,6	1103,3	1235,2	1409,4	1633,7	1808,7	2001,5	2202,7
Cooling												
Standard unit Full load performances*	CW1	Nominal capacity	kW	550,3	717,3	790,8	879,8	1007,0	1167,2	1302,3	1441,7	1577,8
		EER net	kW/kW	5,39	5,53	5,18	5,02	5,15	5,13	5,38	5,42	5,13
		Eurovent class		A	A	A	B	A	A	A	A	A
		EER gross***		5,55	5,70	5,32	5,14	5,30	5,33	5,63	5,69	5,39
	CW2	Nominal capacity	kW	631	823	917	1014	1134	1348	1441	1638	1794
		EER net	kW/kW	8,00	8,43	7,79	7,61	7,86	7,80	8,04	8,11	7,49
		Eurovent class		A	A	A	A	A	A	A	A	A
		EER gross***		8,41	8,88	8,19	7,94	8,25	8,37	8,68	8,78	8,17
Seasonal energy efficiency		SEER _{12/7°C} Comfort low temp.	kW/kW	9,70	9,55	9,54	9,79	9,59	9,49	9,50	9,48	9,14
		SEER _{23/18°C} Comfort medium temp.	kW/kW	10,91	11,65	12,00	11,42	11,21	11,01	11,03	11,05	10,65
		SEPR _{12/7°C} Process high temp.	kWh/kWh	9,48	10,31	9,78	9,05	9,26	9,44	9,49	9,75	9,32
		ESEER	kW/kW	8,55	8,47	8,40	8,70	8,21	8,15	8,00	8,04	7,93
		ESEER gross***	kW/kW	9,74	9,62	9,48	9,79	8,96	9,66	9,51	9,74	9,77
Sound levels												
standard unit												
Sound power ⁽¹⁾			dB(A)	89	92	94	92	94	95	94	95	97
Sound pressure at 10 m ⁽²⁾			dB(A)	57	60	62	60	62	63	62	63	65
Dimensions												
Standard unit												
Length			mm	3140	3160	3360	4345	4345	4345	4800	4800	4800
Width			mm	1270	1310	1335	1385	1385	1385	1385	1390	1410
Height			mm	1780	1880	1965	2036	2036	2036	2000	2050	2100
Operating weight⁽³⁾												
Standard unit			kg	2402	2930	3376	4831	4855	4904	5504	6164	6730
Compressors												
MagLev compressor TT300 / TT350												
Circuit A				2	2	2	1	1	1	2	2	2
Circuit B				-	-	-	2	2	2	2	2	2

* In accordance with standard EN14511-3:2013.
 ** In accordance with standard EN14825:2013, average climate
 *** Values not Eurovent certified. Calculation without the impact of the exchanger pressure drop.
 HW1 Heating mode conditions: Evaporator entering/leaving water temperature 10°C/7°C, condenser entering/leaving water temperature 30°C/35°C, evaporator and condenser fouling factor 0 m². k/W
 HW2 Heating mode conditions: Evaporator entering/leaving water temperature 10°C/7°C, condenser entering/leaving water temperature 40°C/45°C, evaporator and condenser fouling factor 0 m². k/W
 CW1 Cooling mode conditions: Evaporator water entering/leaving temperature 12°C/7°C, condenser entering/leaving water temperature 30°C/35°C, evaporator and condenser fouling factor 0 m².K/W
 CW2 Cooling mode conditions: Evaporator water entering/leaving temperature 23°C/18°C, condenser entering/leaving water temperature 30°C/35°C, evaporator and condenser fouling factor 0 m².K/W
SEER_{12/7°C} & SEPR_{12/7°C} Applicable Ecodesign regulation: (EU) No 2016/2281
SEER_{23/18°C} Applicable Ecodesign regulation: (EU) No 2016/2281
 (1) in dB ref=10⁻¹² W, 'A' weighted. Declared dual-number noise emission values in accordance with ISO 4871 with an associated uncertainty of +/-3dB(A). Measured in accordance with ISO 9614-1 and certified by Eurovent.
 (2) In dB ref 20μPa, 'A' weighted. Declared dual-number noise emission values in accordance with ISO 4871 with an associated uncertainty of +/-3dB(A). For information, calculated from the sound power Lw(A).
 (3) Values are guidelines only. Refer to the unit name plate.



Eurovent certified values

PHYSICAL DATA, STANDARD UNITS

19PV		550	720	800	900	1010	1180	1300	1450	1600
Refrigerant⁽³⁾		R-134a								
Circuit A	kg	95,0	120,0	140,0	100,0	100,0	100,0	125,0	135,0	150,0
	teqCO ₂	135,9	171,6	200,2	143,0	143,0	143,0	178,8	193,1	214,5
Circuit B	kg	-	-	-	125,0	125,0	125,0	125,0	135,0	150,0
	teqCO ₂	-	-	-	178,8	178,8	178,8	178,8	193,1	214,5
Capacity control		Touch'Pilot, electronic expansion valves (EXV)								
Minimum capacity	%	15	10	10	10	10	10	10	10	10
Evaporator		Flooded multi-pipe type								
Water volume	l	115	165	180	285	285	285	330	330	365
Water connections (Victaulic)	in	6	6	8	8	8	8	8	8	8
Drain and vent connections (NPT)	in	3/8	3/8	3/8	3/8	3/8	3/8	3/8	3/8	3/8
Max. water-side operating pressure	kPa	1000	1000	1000	1000	1000	1000	1000	1000	1000
Condenser		Flooded multi-pipe type								
Water volume	l	145	157	187	308	308	308	339	487	487
Water connections (Victaulic)	in	6	6	8	8	8	8	8	8	8
Drain and vent connections (NPT)	in	3/8	3/8	3/8	3/8	3/8	3/8	3/8	3/8	3/8
Max. water-side operating pressure	kPa	1000	1000	1000	1000	1000	1000	1000	1000	1000

(3) Values are guidelines only. Refer to the unit name plate.

ELECTRICAL DATA, STANDARD UNITS

19PV		550	720	800	900	1010	1180	1300	1450	1600
Power circuit supply										
Nominal voltage	V-ph-Hz	400-3-50								
Voltage range	V	360-440								
Control circuit supply										
24 V via the built-in transformer										
Maximum operating input power⁽¹⁾- Standard unit										
Circuit 1 ^(a)	kW	140	201	230	76	116	111	133	187	222
Circuit 2 ^(a)	kW	-	-	-	152	152	222	204	187	222
Unit with option 81	kW	-	-	-	229	269	333	337	375	445
Power factor at maximum power ⁽¹⁾		0,92	0,92	0,92	0,92	0,92	0,92	0,92	0,92	0,92
Total Harmonic Distortion Intensity	%	<45	<45	<45	<45	<45	<45	<45	<45	<45
Nominal operating current draw⁽²⁾- Standard unit										
Circuit 1 ^(a)	A	162	208	244	93	129	119	151	210	243
Circuit 2 ^(a)	A	-	-	-	185	187	237	229	210	243
Unit with option 81	A	-	-	-	278	315	356	380	420	486
Maximum operating current draw (Un)⁽¹⁾- Standard unit										
Circuit 1 ^(a)	A	220	315	361	119	183	174	209	294	349
Circuit 2 ^(a)	A	-	-	-	239	239	349	319	294	349
Unit with option 81	A	-	-	-	358	422	523	528	588	697
Maximum current (Un-10%)⁽¹⁾- Standard unit										
Circuit 1 ^(a)	A	237	340	390	129	197	188	225	318	377
Circuit 2 ^(a)	A	-	-	-	258	258	377	345	318	377
Unit with option 81	A	-	-	-	387	456	565	570	635	753
Maximum start-up current(Un) - Standard unit⁽³⁾										
Lower than max current										
Dissipated power of electrical equipment ⁽¹⁾	W	782	1249	1249	1144	1347	1814	1884	2351	2351

(1) Values obtained at unit continuous maximum operating conditions (data given on the unit nameplate)

(2) Standardised EUROVENT conditions, water-cooled exchanger water inlet/outlet = 12°C/7°C, condenser entering/leaving water temperature = 30°C/35°C

(3) Start-up current is limited by the soft-start controller included in the compressor.

(a) When the machines are equipped with two power supplies, circuit 1 supplies the refrigerant circuit A and circuit 2 supplies the refrigerant circuit B

Note: Options 84 and 84R are not included in these values.

19PV		550	720	800	900	1010	1180	1300	1450	1600
Short-circuit withstand current (TN system)										
Circuit A+B	KA	50	50	50	50	50	50	50	50	50

(1) If another current limitation protection device is used, its time-current and thermal constraint (I^2t) trip characteristics must be at least equivalent to those of the recommended protection.

Note: The short-circuit stability current values above are suitable with the TN system.

ELECTRICAL DATA, STANDARD UNITS

Electrical data notes and operating conditions, 19PV units

• **As standard:**

19PV 550 to 19PV800 units have a single power connection point located immediately upstream of the main supply disconnect switch.

19PV 900 to 19PV 1600 units have two connection points located immediately upstream of the main supply disconnect switches.

• **Control box includes the following standard features:**

- Two disconnect switches per circuit: One main supply disconnect switch and one disconnect switch for the supply of the control part, the undervoltage protection circuit and the motor mechanism module,
- Filtering compressor current devices
- Anti-short cycle protection devices
- Control devices supply by internal transformers.

• **Field connections:**

All connections to the system and the electrical installations must be in accordance with all applicable codes.*

- 19PV units are designed and built to ensure conformance with these codes. The recommendations of European standard EN 60204-1 (corresponds to IEC 60204-1) (machine safety - electrical machine components - part 1: general regulations) are specifically taken into account, when designing the electrical equipment.
- Generally the recommendations of IEC 60364 are accepted as compliance with the requirements of the installation regulation.
- Annex B of standard EN 60204-1 specifies the electrical features used for the operation of the units. The features below complete the informations given in this document:

1. Physical environment:

The classification of environment is specified in standard EN 60364:

- Indoor installation**,
- Ambient temperature range: minimum temperature +5°C to +42°C, class AA4
- Altitude: AC1 of 2000 m or less,
- Presence of water: Class AD2 (possibility of water droplets)**
- Presence of hard solid: Class AE2 (no significant dust present)**,
- Presence of corrosive and polluting substances, class AF1 (negligible),
- Competence of persons: BA4 (Persons wise),
- Overvoltage category: II (2,5KV).

2. Compatibility for low-frequency conducted disturbances according to class 2 levels per IEC61000-2-4 standard:

- Power supply frequency variation: +- 2Hz
- Phase imbalance : 2%

3. The neutral (N) line must not be connected directly to the unit (if necessary use a transformer).

4. Overcurrent protection of the power supply conductors is not provided with the unit.

5. The factory-installed disconnect switch(es)/circuit breaker(s) are of a type suitable for power interruption in accordance with EN 60947-3 (corresponds to IEC 60947-3).

6. The units are designed for connection to TN networks (IEC 60364). In IT networks, if noise filters are integrated into the compressor(s) variable frequency drive(s), this will render the units unsuitable for their intended purpose. In addition, the equipment characteristics in case of insulation failure are modified.

For IT networks, the earth connection must not be at the network earth. Provide a local earth; consult competent local organisations to complete the electrical installation.

7. Electromagnetic environment: classification of the electromagnetic environment is described in standard EN 61800-3 (corresponds to IEC 61800-3):

- Immunity to external interference defined by the second environment***
- Interference emission as defined in category C2

Warning: In a residential environment, this product may cause radio interference in which case additional mitigation measures could be required.

The compressor variable frequency drive is a source of perturbations from the harmonic currents. An investigation could be necessary to check that the perturbations don't exceed the compatibility limits with the other devices connected on the same power supply network. In an electrical installation, the levels of compatibility to be observed at the internal coupling point (IPC) to which other loads are connected are described in standard IEC 61000-2-4.

- Leakage currents: If protection by monitoring the leakage currents is necessary to ensure the safety of the installation, the presence of additional leakage currents introduced by the use of variable frequency drive(s) in the compressor must be considered.

In particular, the reinforced immunity protection types and a control value not lower than 150 mA are recommended when selecting differential protective devices.

Note: If particular aspects of an actual installation do not conform to the conditions described above, or if there are other conditions which should be considered, always contact your local Carrier representative.

* Generally, the recommendations of the standard of International Electrotechnical Commission (IEC60364) are identified to meet the requirements of the installation guidelines.

** The required protection level for this class is IP21B or IPX1B (according to reference document IEC 60529). All 19PV units are IP23 and fulfil this protection condition.

*** Example of second environment installations: Industrial areas, technical facilities supplied by a dedicated transformer

PARTIAL LOAD PERFORMANCE

With the rapid increase in energy costs and the care about environmental impacts of electricity production, power consumption of air conditioning equipment has become an important topic.

The energy efficiency of a unit at full load is rarely representative of the actual performance of the units, as on average a unit works less than 5% of the time at full load.

SEER for comfort chillers (in accordance with EU ECODESIGN)

The **SEER** (Seasonal Energy Efficiency Ratio) measures the seasonal energy efficiency of comfort **chillers** by calculating the ratio between annual cooling demand of the building and annual energy demand of the chiller. It takes into account the energy efficiency achieved for each outdoor temperature weighted by the number of hours observed for each of these temperatures, using actual climate data.

SEER is a new way of measuring the true energy efficiency of chillers for comfort cooling over an entire year. This new indicator gives a more realistic indication of the real energy efficiency and environmental impact of a cooling system (Ecodesign Regulation 2016/2281).

The heat load of a building depends on many factors, such as the outdoor air temperature, the exposure to the sun and its occupancy.

Consequently, it is preferable to use the average seasonal energy efficiency, calculated at several operation points that are representative of unit use.

ESEER (in accordance with EUROVENT)

The **ESEER** (European Seasonal Energy Efficiency Ratio) permits evaluation of the average energy efficiency at part load, based on four operating conditions defined by Eurovent. The ESEER is the average value of energy efficiency ratios (EER) at different operating conditions, weighted by the operating time.

Load %	Condenser entering water temperature, °C	Energy efficiency	Operating time, %
100	30	EER ₁	3
75	26	EER ₂	33
50	22	EER ₃	41
25	18	EER ₄	23

$$\text{ESEER} = \text{EER}_1 \times 3\% + \text{EER}_2 \times 33\% + \text{EER}_3 \times 41\% + \text{EER}_4 \times 23\%$$

Note: Constant leaving chilled water temperature 7°C.

SEPR for process chillers (in accordance with EU ECODESIGN)

The **SEPR** (Seasonal Energy Performance Ratio) measures the seasonal energy efficiency of **process chillers** by calculating the ratio between annual cooling demand of the process and annual energy demand of the chiller. It takes into account the energy efficiency achieved at each outdoor temperature of an average climate weighted by the number of hours observed for each of these temperatures.

SEPR is a new way of measuring the true energy efficiency of chillers for **process cooling** over an entire year. This new indicator gives a more realistic indication of the real energy efficiency and environmental impact of the cooling system (Ecodesign Regulation 2015/1095 or 2016/2281).

SOUND LEVELS

Standard Units

Sound power levels ref 10^{-12} W ± 3 dB (L_w)

19PV	SOUND POWER LEVEL SPECTRUM (dB)							Overall power level dB(A)
	125 Hz	250 Hz	500 Hz	1000 Hz	2000 Hz	4000 Hz	8000 Hz	
550	71	77	78	85	80	79	84	89
720	72	77	84	84	80	86	89	92
800	76	81	85	86	83	87	92	94
900	76	82	82	88	84	82	88	92
1010	77	82	85	88	84	85	91	94
1180	77	82	86	87	84	88	93	95
1300	75	80	85	88	83	87	90	94
1450	75	80	87	87	83	89	92	95
1600	79	84	88	89	86	90	95	97

Sound pressure level ref 2×10^{-5} Pa ± 3 dB (L_p)

Measurement conditions: free field, 10 metres from machine, 1.50 metres above floor level, directivity 2

19PV	SOUND PRESSURE SPECTRUM (dB)							Overall power level dB(A)
	125 Hz	250 Hz	500 Hz	1000 Hz	2000 Hz	4000 Hz	8000 Hz	
550	39	45	46	54	48	48	52	57
720	40	45	52	52	48	54	57	60
800	44	49	53	54	51	55	60	62
900	44	49	50	55	52	50	56	60
1010	45	50	53	56	52	53	59	62
1180	44	50	54	55	52	55	61	63
1300	42	48	53	56	51	55	58	62
1450	42	48	55	55	50	56	60	63
1600	46	52	56	57	54	57	63	65

Note: The sound levels by octave bands are given for information only and not contractually binding. Only the overall power level is contractual.

Low noise option (Option 15)

Sound power levels ref 10^{-12} W ± 3 dB (L_w)

19PV	SOUND POWER LEVEL SPECTRUM (dB)							Overall power level dB(A)
	125 Hz	250 Hz	500 Hz	1000 Hz	2000 Hz	4000 Hz	8000 Hz	
550	72	78	79	85	79	77	81	88
720	71	78	83	82	78	83	84	89
800	84	82	85	85	81	83	87	91
900	71	82	82	88	83	79	84	91
1010	81	83	84	88	83	82	86	92
1180	85	83	86	86	82	84	88	92
1300	75	81	85	87	82	84	86	92
1450	74	81	86	85	81	86	87	92
1600	87	85	88	88	84	86	90	94

OPERATING LIMITS AND OPERATING RANGES

19PV		Minimum	Maximum
Evaporator			
Entering temperature at start-up	°C	-	35
Leaving temperature during operation	°C	3,3	20
Entering/leaving water temperature difference	K	3	11,1
Condenser			
Entering temperature at start-up	°C	13 ⁽¹⁾	-
Leaving temperature during operation	°C	14 ⁽¹⁾	50
Entering/leaving water temperature difference	K	3	11,1

(1) For lower condenser temperatures a water flow control valve must be used at the condenser (two or three-way valve). Please refer to Control for low condensing temperature option to ensure the correct condensing temperature.

19PV MAP

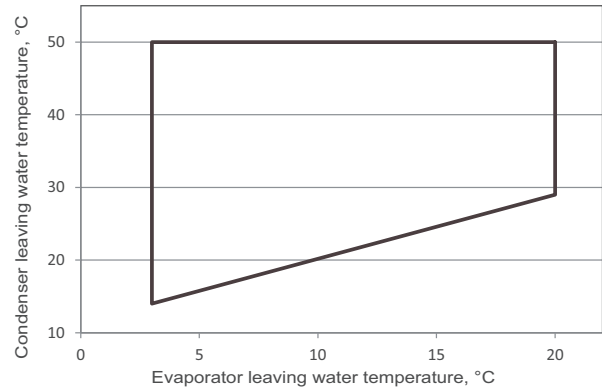

NOTES: Ambient temperatures: During storage and transport of the 19PV units (including by container) the minimum and maximum permissible temperatures are -20°C and 66°C.

For more precise details refer to the unit selection program.

SYSTEM WATER VOLUME - EXCHANGER WATER FLOW RATE

The Touch'Pilot controller is equipped with anticipation logic making it highly flexible in adjusting operation to parameter drift, particularly on hydraulic systems with low water volumes. By adjusting compressor running times, it prevents short-cycle protection cycles from starting and, in most cases, eliminates the need for a buffer tank.

Note: The minimum volumes of water are calculated on EUROVENT rated conditions:

- Chilled water temperature =12°C/7°C
- Condenser water temperature =30°C/35°C

This value is applicable for most air conditioning applications (unit with fan coil units).

Note: For installations running with a low volume of water (unit with air handling unit) or for industrial processes, the buffer tank is essential.

19PV	550	720	800	900	1010	1180	1300	1450	1600
Minimum installation volume (l)									
Air conditioning application	1770	2310	2570	2890	3240	3790	4170	4640	5130
Industrial process application	3530	4620	5140	5780	6480	7570	8330	9290	10250
Evaporator water flow rate (m³/h)									
Minimum ⁽¹⁾	34	34	34	34	61	61	61	61	61
Maximum ⁽³⁾	179	235	257	281	289	286	295	295	329
Condenser water flow rate (m³/h)									
Minimum ⁽²⁾	21	21	36	36	36	36	36	36	36
Maximum ⁽³⁾	245	299	346	486	457	454	428	594	526

(1) Minimum evaporator flow rate based on a water velocity of 0,5 m/s.

(2) Minimum condenser flow rate based on a water velocity of 0,3 m/s.

(3) Maximum flow rate based on a pressure drop of 120 kPa (units with two evaporator passes and two condenser passes).

DIMENSIONS

19PV 550 to 800

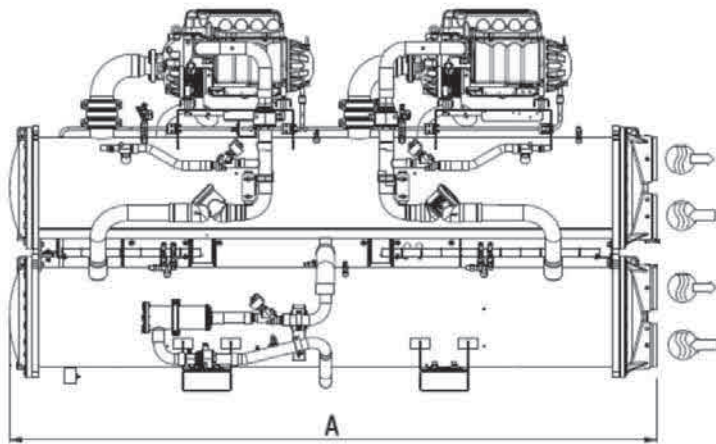
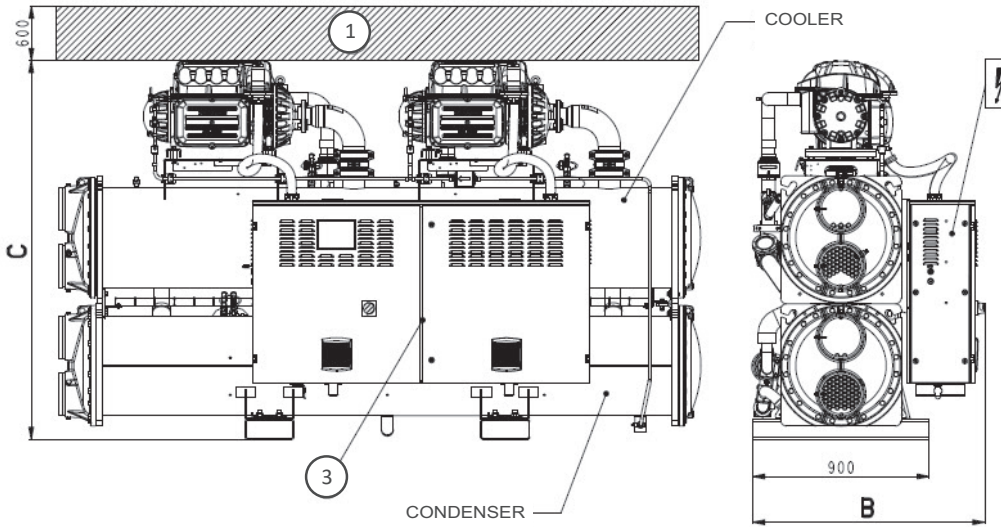

Units sizes	Dimensions in mm			
	A	B	C	D
19PV				
550	3045	1120	1745	2800
720	3070	1155	1846	2800
800	3270	1190	1925	3000

Legend:

All dimensions are given in mm.

- ① Required clearance for maintenance
- ② Recommended clearance for tube removal
- Water inlet
- Water outlet
- Electrical cabinet

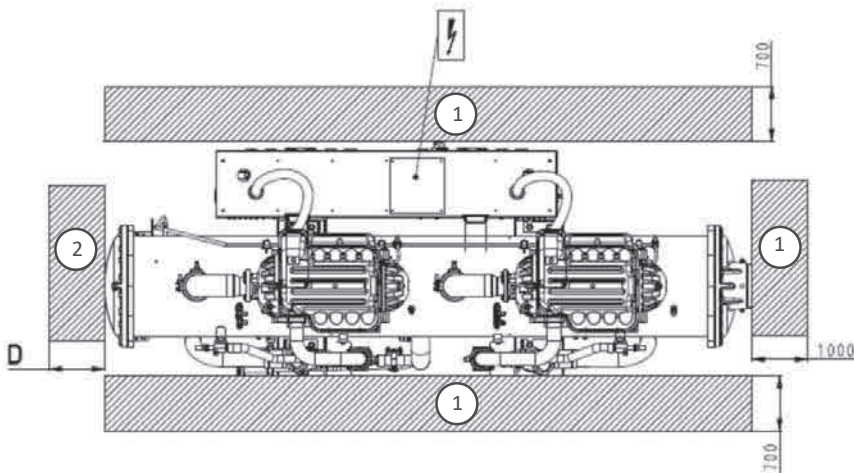

NOTE: Drawings are not contractually binding. Before designing an installation, consult the certified dimensional drawings, available on request.

DIMENSIONS

19PV 900 to 1180

COOLING

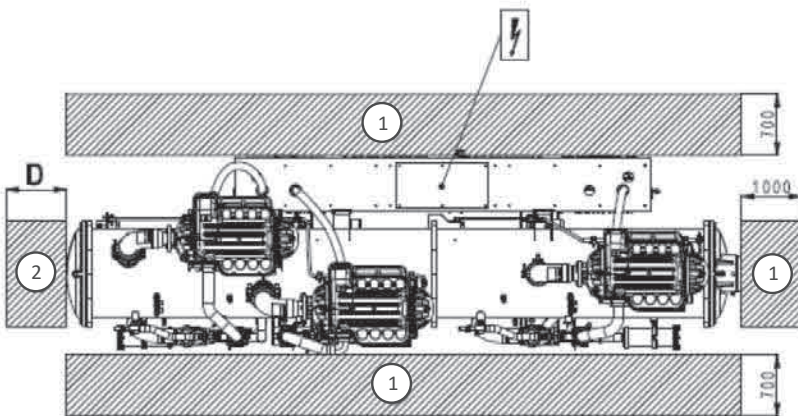
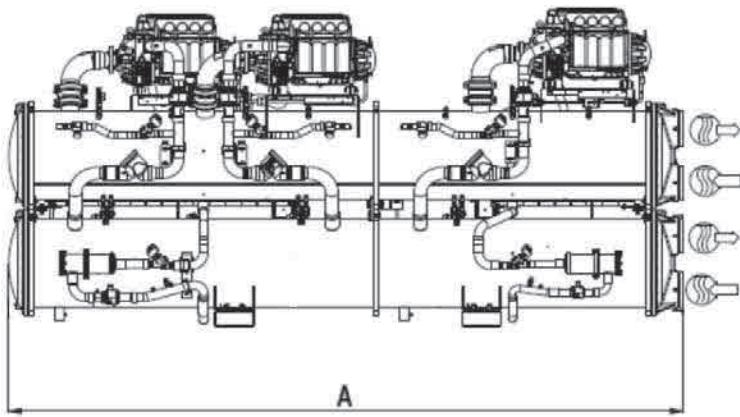
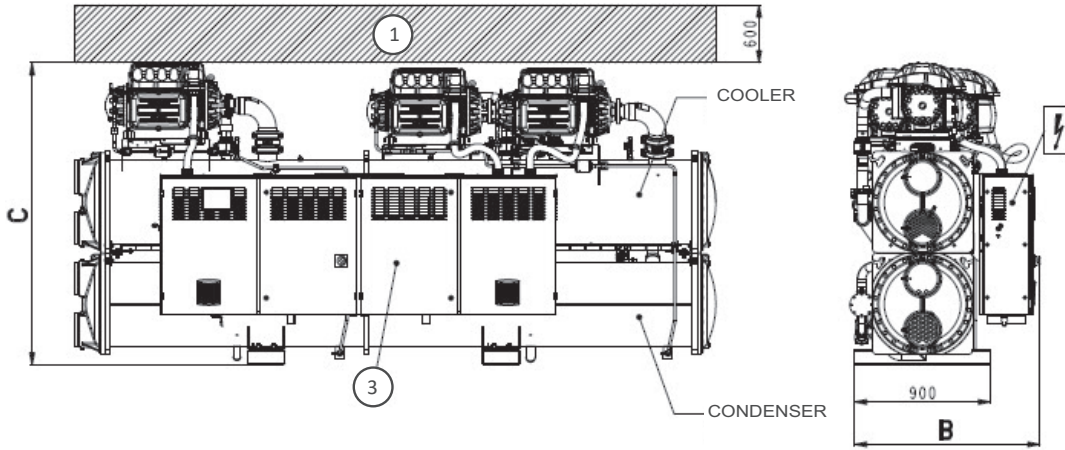

Units sizes	Dimensions in mm			
	A	B	C	D
19PV				
900	4257	1290	1955	3950
1010	4257	1290	1955	3950
1180	4257	1290	1955	3950

Legend:

All dimensions are given in mm.

- ① Required clearance for maintenance
- ② Recommended clearance for tube removal
- Water inlet
- Water outlet
- Electrical cabinet

NOTE: Drawings are not contractually binding. Before designing an installation, consult the certified dimensional drawings, available on request.

DIMENSIONS

19PV 1300 to 1600

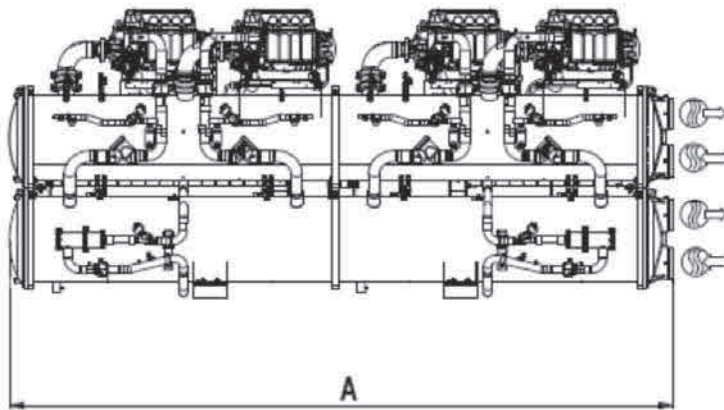
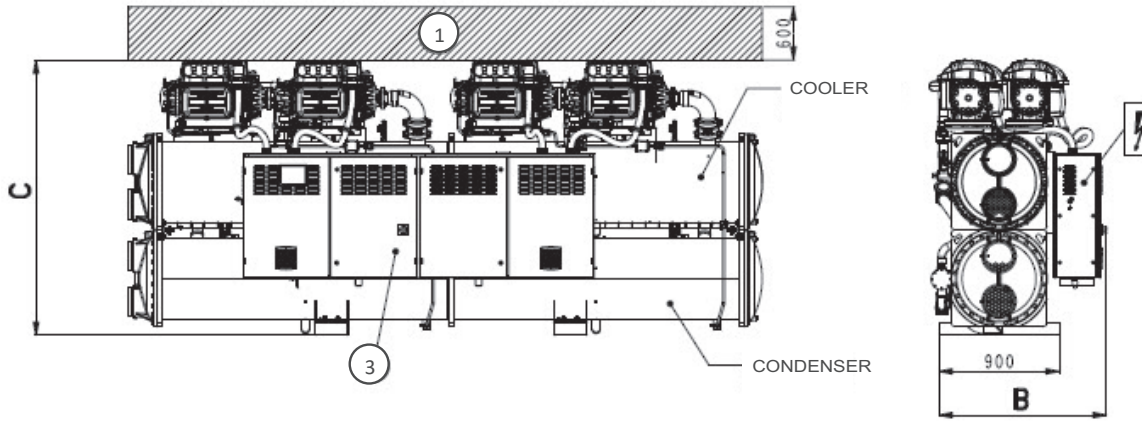

Units sizes	Dimensions in mm			
	A	B	C	D
19PV				
1300	4705	1290	1955	4400
1450	4740	1290	2011	4400
1600	4740	1325	2065	4400

Legend:

All dimensions are given in mm.

- ① Required clearance for maintenance
- ② Recommended clearance for tube removal
- Water inlet
- Water outlet
- Electrical cabinet

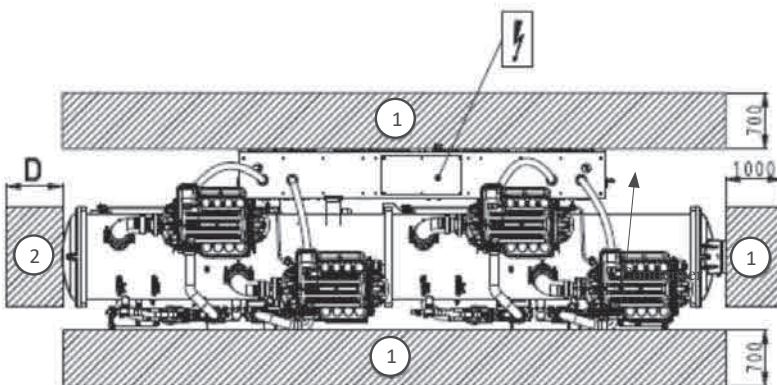

NOTE: Drawings are not contractually binding. Before designing an installation, consult the certified dimensional drawings, available on request.

DRYCOOLERS

CARRIER's **09PE** and **09VE** dry coolers are compatible with 19PV water-cooled water chillers.

09PE et **09VE** are available in a wide selection of sizes and with various fan speeds to meet the size and acoustic requirements of any site.

09PE



09VE



COOLING SCHEMATIC INSTALLATION DIAGRAM

Cooling installation with drycooler

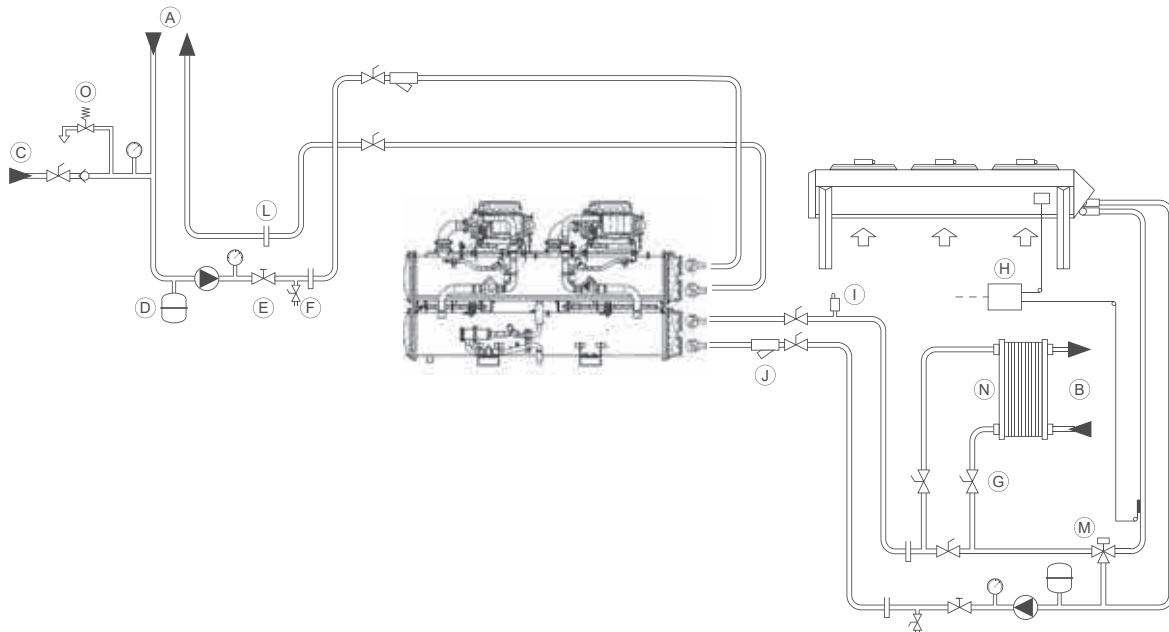

- | | | |
|----------------------------|----------------------------|------------------------------|
| (A) Chilled water circuit | (F) Drain | (L) Thermowell |
| (B) Recovery water circuit | (G) Shut-off valve | (M) 3-way hydraulic valve |
| (C) Water supply valve | (H) Temperature controller | (N) Cleanable heat exchanger |
| (D) Expansion vessel | (I) Air bleed valve | (O) Safety valve |
| (E) Control valve | (J) Water filter | |

CONTROL

USER-FRIENDLY INTERFACE CONSOLE

- User-friendly 7 inch touchscreen.
- Technical literature include on the controller
- Information displayed in a choice of languages.
- Temperature and pressure readings.
- Operating and fault status diagnostics.
- Master/slave control of two machines in parallel.
- Fault memory management.
- Pump management.
- Time schedule.
- **IP Web server connectivity.**
- Programmable maintenance.
- Preventive maintenance.
- FGAS maintenance.
- **E-mail alerts.**

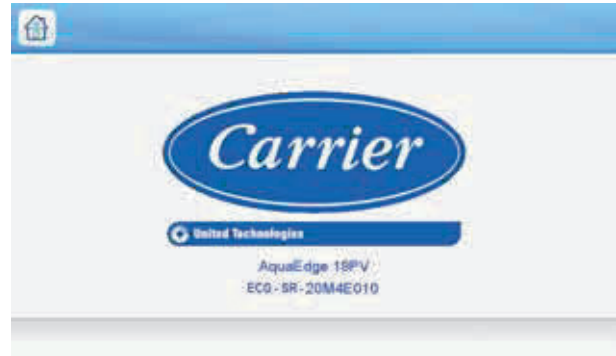

PRODUCT FUNCTIONALITY



Via dry contact
COMMUNICATION
Customer BMS

Via BUS
communication

<p>DRYCOOLER Control</p> <p>TouchPilot management for CARRIER 09PE - 09VE drycooler via a simple bus</p> <p>Dry cooler used as</p> <ul style="list-style-type: none"> - Heat rejection - Free cooling source 
<p>POTENTIAL-FREE (DRY) CONTACTS AVAILABLE AS STANDARD</p> <p>Inputs:</p> <ul style="list-style-type: none"> - Unit On/Off switch - Heat/cool Switch (used to switch mode in remote) - Set-point switch (volt free contact to determine active set-point 1/2) - Set-point offset (4-20 mA signal to offset the active set-point of the unit) - Condenser flow switch - Capacity limit control (4-20mA to set demand limit) - Ice set-point (closing this input disables ice set-point) - Remote interlock - Customer interlock (open=unit shuts down / closed = enable to operate) - Time schedule override Switch <p>Outputs:</p> <ul style="list-style-type: none"> - Alarm relay (report alarm state) - Running relay (Signal running status) - Evaporator pump control (control by 0-10V command) - Chiller Alert state - Chiller shutdown general fault reporting - Chiller capacity information output (0 to 10 V signal) - Compressor status
<p>AVAILABLE OUTPUTS</p> <ul style="list-style-type: none"> - MODBUS-JBUS TC/IP (standard) open protocol - BACNET IP protocol (option)