

NEW

VARIABLE-SPEED SCREW LIQUID CHILLER WITH GREENSPEED® INTELLIGENCE



- Outstanding performance
- Low sound levels
- Intelligence and connectivity
- Environmentally responsible
- Wide range of applications
- Simple installation and maintenance

COOLING

30KAV
30KAV-ZE available in 2018

Nominal cooling capacity 493-1079 kW

The AquaForce® Vision 30KAV liquid chillers with Greenspeed® Intelligence are the premium solution for commercial and industrial applications where installers, consultants and building owners require superior reliability and optimal performances, especially at part load.

The 30KAV units are designed to exceed European Ecodesign directive requirements in terms of energy efficiency, versatility and operating sound levels. This result is achieved through the optimised combination of proven best-in-class technologies that include:

- 2nd generation of high-efficiency variable-speed twin screw compressors with built in volume index control (Vi) valve for optimal full and part load performance and Integrated Resonator Array (IRA) for low sound operation
- 6th generation of Carrier Flying Bird™ fans with AC or EC motor depending on options.
- Carrier flooded shell-and-tube evaporator with new copper tubes for low pressure drops
- 3rd generation of “W” profile Carrier Novation™ microchannel heat exchangers with optional Enviro-Shield coatings.
- Carrier Touch Pilot® control with color touch screen user interface that includes 10 languages and new smart energy monitoring function.



CARRIER participates in the ECP programme for LCP/HP
Check ongoing validity of certificate:
www.eurovent-certification.com

CUSTOMER BENEFITS

AquaForce® Vision 30KAV liquid chillers with Greenspeed® Intelligence adapt effortlessly to a wide range of applications. An extended operating range covering ambient temperatures from -20 to 55°C makes it ideal for all areas of activity. From high-end office buildings and hotels to healthcare facilities, data centers and industrial projects, 30KAV meets the most demanding expectations in terms of energy efficiency and savings, whatever the climate and wherever the location.

Furthermore, the advanced Touch Pilot™ intelligent control system displays operating parameters in real time, making it intuitive and particularly user-friendly. 30KAV also features innovative smart energy monitoring, providing users with smart data such as real time electric energy consumption, cooling capacity, and instantaneous and average seasonal energy efficiency ratios. For further energy savings, 30KAV can be monitored remotely by Carrier experts for energy consumption diagnosis and optimization.

The range is available in 4 efficiency levels.

■ 30KAV standard unit

The AquaForce® 30KAV is equipped with variable-speed screw compressor and variable-speed fans with AC motors. The 30KAV is optimised to meet the most demanding technical and economic requirements while offering high seasonal energy efficiency levels.
(Average SEER of 5.17, average EER of 3.0)

■ 30KAV with EC fans (option 17)

The 30KAV with EC fans option enhances the seasonal energy efficiency and offers state of the art EC fan technology as standard.
(Average SEER of 5.23, average EER of 3.0)

■ 30KAV with High Energy Efficiency (option 119)

The 30KAV with High Energy Efficiency option is equipped with variable-speed fans with AC motor and additional heat exchange surface to deliver optimum performance at both full load and part load.
(Average SEER of 5.35, average EER of 3.4)

■ 30KAV with High Energy Efficiency+ (option 119+)

The 30KAV with High Energy Efficiency+ option is equipped with EC fans and additional heat exchange surface to provide the highest possible seasonal energy efficiency.
(Average SEER of 5.45, average EER of 3.4)

Outstanding energy performance

■ The 30KAV with “High energy efficiency+” is designed for very high performance both at full and part load: average SEER 5.45, average EER 3.4 as per EN14825 & EN14511.

■ The high energy efficiency is achieved through:

- 2nd generation of Carrier high-efficiency variable-speed twin-screw compressors with built in volume index control (Vi) valve for both optimal full and part load performance
- Variable-speed Flying Bird™ fans with EC motor minimising power consumption while delivering optimum air flow
- Novation™ aluminum condenser with high-efficiency micro-channel coils technology

- New Carrier flooded shell-and-tube evaporator with new copper tubes for low pressure drops
- Electronic expansion device permitting operation at a lower condensing pressure and improved utilisation of the evaporator heat exchange surface (superheat control)
- Economiser system with electronic expansion device for increased cooling capacity.

■ Optimised electrical performance:

- Negligible start-up current (value is lower than the maximum unit current draw)
- High displacement power factor (above 0.98)
- EMC compliance with Class 3 requirements of the EU standard EN61800-3 (Class 2 is possible as an option).

■ Hydraulic module with variable-speed dual pump

- Variable-speed, dual pumps which automatically adjust the water flow to match the needs of the building or process load variations.
- 3 pump control modes available: constant water flow with possibility to reduce the pump speed when there is no cooling demand, variable water flow with constant delta T or constant delta P control.

■ Smart energy monitoring

- Innovative smart energy monitoring providing users with smart data such as real time electric energy consumption, cooling capacity, and instantaneous and average seasonal energy efficiency ratios.
- For further energy savings, 30KAV can be monitored remotely by Carrier experts for energy consumption diagnosis and optimization.

Built-in reliability and easy servicing

The 30KAV units offer enhanced performance as well as Carrier's acclaimed product quality and reliability. Major components were chosen, selected and tested to minimise the possibility of failure.

■ 2nd generation of variable-speed twin-screw compressors:

- The screw compressors are industrial-type with oversized bearings and motor cooled by suction gas, with a proven failure rate lower than 0.1%.
- Air-cooled compressor variable-speed drive (VSD) to ensure reliable operation and easy maintenance. (Glycol-cooled variable-speed drive (VSD) types are subject to higher failure rates due to glycol pump issue. Refrigerant-cooled variable-speed drive (VSD) types are subject to higher compressor vibration levels causing possible failures in the long term).
- Compressor bearing life exceeding 100 000 hours
- All components related to the compressor assembly are easily accessible on site minimising down-time.

■ Variable-speed fans:

- 30KAV is fitted with variable-speed asynchronous fan-motors as standard. One variable-speed drive (VSD) is sized to manage a group of fans per refrigerant circuit reducing first cost while ensuring high part-load efficiency.
- 30KAV with High Energy Efficiency+ option is fitted with variable-speed EC fan-motors. Each EC fan is controlled independently ensuring continuous chiller operation in case of motor or drive failure.

CUSTOMER BENEFITS

- **Air-cooled condenser:**
 - Novation™ aluminum micro-channel heat exchanger (MCHE) with high corrosion resistance. The all aluminum design eliminates the formation of galvanic currents between aluminum and copper that cause coil corrosion in saline or corrosive environments.
 - Enviro-shield™ coating for MCHE used in standard and mildly corrosive environments with superior durability confirmed through 5000 hours testing in constant neutral salt spray per ASTM B117 and superior heat transfer performances confirmed through 2000 hours testing per CM1 (Carrier proprietary testing).
 - Super Enviro-shield™ coating for MCHE used in highly corrosive environments (industry or marine applications) with superior durability confirmed through 5000 hours testing in constant neutral salt spray per ASTM B117 and superior heat transfer performances confirmed through 2000 hours testing per CM1 (Carrier proprietary testing).
- **Evaporator:**
 - Carrier designed flooded evaporator with mechanically cleanable water tubes
 - Electronic paddle-free flow switch to ensure prompt alarm in case of poor liquid flow rate
 - Thermal insulation with aluminum sheet finish (option) improved resistance to mechanical and UV damage.
- **Refrigerant circuits:**
 - Two independent refrigerant circuits to secure partial cooling, if one of the two develops a fault.
- **Auto-adaptive control:**
 - Control algorithm prevents excessive compressor cycling (Carrier patent)
 - Automatic compressor unloading in case of abnormally high condensing pressure. If condenser coil fouling or fan failure occurs, the Aquaforce continues to operate, but at reduced capacity.
- **Exceptional endurance tests:**
 - To design critical components and sub-assemblies to minimise the risk of failure on site, Carrier uses specialised laboratories and advanced dynamic simulation tools.
 - To ensure that the units reach customer sites in the same condition as they are when tested in the factory, Carrier tests the machine behavior while being moved along a 250 km trial. The test-route is based on a military standard and is the equivalent to 5000km by truck in a normal road.
 - To ensure coils corrosion resistance, salt mist corrosion resistance test are performed in UTC's laboratory.

In addition, to maintain unit performance throughout its operating life, whilst minimising maintenance costs, end users can access the "Carrier Connect" remote monitoring service.

Minimised operating sound levels

- The Greenspeed® Intelligence, featuring variable-speed screw compressors and condenser fans, minimises noise levels at part load operation.

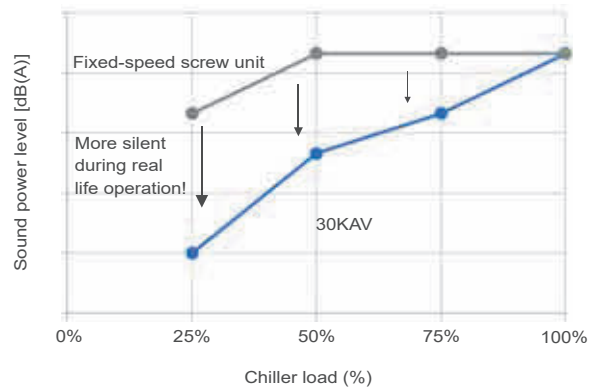

- **Standard unit features include:**
 - The new generation of Carrier 06Z variable-speed twin screw compressor with integrated resonator array to reduce the noise level by 6 dB(A) compared with 06T twin screw compressor previous generation.
 - The 6th generation of silent Flying Bird™ fans with new fan blade design inspired by nature, help reduce airflow noise.
- **30KAV is available with 4 sound levels to match the most sensitive environments:**
 - Standard: standard unit configuration with new generation of low sound screw compressor and fans
 - Low noise option: addition of high-performance compressor sound enclosure
 - Very low noise option: addition of high-performance compressor sound enclosure and fan operation at lower rotational speed.
 - Ultra low noise option: option under development (available during 2018).

Easy and fast installation

- **Built-in variable speed pumps up to 800 kW**
 - Full hydraulic module with dual pumps (low or high pressure as required) and optional expansion tank
 - Automatic nominal water flow adjustment through electronic control on the user display
- **Compact units for easy transportation and installation.**
 - Dimensions 25% smaller than the previous 30XAV generation
 - Similar dimensions as the old 30GX chillers for easy replacement of the installed base.
- **Simplified electrical connections:**
 - Main disconnect switch
 - Transformer supply to the integrated control circuit (400/24V)
 - Single electrical point of connection
- **Simplified water connections:**
 - Victaulic connections on the evaporator
 - Clearly identified entering and practical reference marks for entering and leaving water connections
 - Possibility to choose different evaporator configurations, 1 or 2 passes.
- **Fast commissioning:**
 - Systematic factory operating test before shipment
 - Functional test for main components, expansion devices, fans and compressors.

CUSTOMER BENEFITS

Environmental care

- The AquaForce® Vision 30KAV liquid chillers with Greenspeed® Intelligence is a boost for green cities and contributes to a sustainable future. Combining a reduced charge of R134a refrigerant and exceptional energy efficiency it significantly lowers energy consumption while reducing carbon dioxide emissions by 25% throughout its life cycle (compared to previous fixed-speed screw liquid chiller generation).
- The AquaForce® Vision 30KAV liquid chiller is equipped with an automatic energy meter that provides estimated instantaneous and cumulative cooling energy output, instantaneous and cumulative electric energy consumption, instantaneous and average seasonal energy efficiency ratios (Accuracy: +/- 5% at nominal condition, +/-10% elsewhere) for unit performance monitoring and verification.
- The AquaForce® Vision 30KAVZE version with PUREtec™ refrigerant designed exclusively for HFO R-1234ze will be available during the course of 2018.
- R-134a: HFC refrigerant with zero ozone depletion potential
- 40% less refrigerant charge: The micro-channel technology used for condenser coils optimises heat transfer while minimising the refrigerant volume.
- Leak tight refrigerant circuits:
 - Reduction of leaks as no capillary tubes and flare connections are used
 - Verification of pressure transducers and temperature sensors without transferring refrigerant charge
 - Discharge line shut-off valve and liquid line service valve for simplified maintenance.
- Refrigerant leak alert: The AquaForce® Vision 30KAV liquid chiller is equipped with an automatic refrigerant leak detection algorithm that can detect serious refrigerant loss at any point on the system (Sensitivity: 25% refrigerant charge loss per circuit, depending on the conditions). The automatic refrigerant leak detection system can help to achieve recognition within pollution prevention assessment programs, ideal for assisting in the design of sustainable buildings.
- Refrigerant leak detection: Available as an option, this additional dry-contact allows reporting of possible leaks. The leak detector (by others) should be mounted in the most likely leak location.

Designed to support Green Building Design

A green building is a building that is environmentally sustainable and has been designed, constructed and is operated to minimise the total impact on the environment.

The resulting building will be economical to operate, offer increased comfort and create a healthier environment for the people who live and work there, increasing productivity.

The air conditioning system can use between 30 and 40% of the annual building energy consumption. Selection of the right air conditioning system is one of the main aspects to consider when designing a green building. For buildings with a variable load throughout the year 30KAV units offer a solution to this important challenge.

A number of green building certification programs exist in the market and offer third-party assessment of green building measures for a wide variety of building types.

The following example looks at how Carrier's new 30KAV range helps customers involved in LEED® building certification.

30KAV and LEED® certification

The LEED® (Leadership in Energy and Environmental Design) green building certification programme is a preeminent programme to rate the design, construction and operation of green buildings with points assigned in seven credit categories:

- Sustainable Sites (SS)
- Water Efficiency (WE)
- Energy & Atmosphere (EA)
- Materials & Resources (MR)
- Indoor Environmental Quality (IEQ)
- Innovation in Design (ID)
- Regional Priority (RP).

There are a number of different LEED® products.

While the strategies and categories assessed remain same, the point distribution varies to address different building types and application needs, for example according to New Construction, Schools, Core & Shell, Retail and Healthcare.

All programmes now use the same point scale:

110 Possible LEED® points

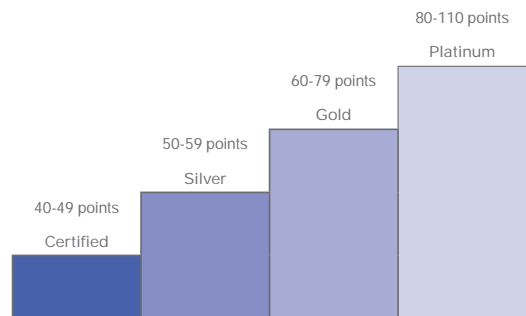

The majority of credits in LEED® rating systems are performance-based and achieving them is dependent on the impacts of each component or sub-system to the overall building.

While the LEED® green building certification programs do not certify products or services, the selection of the right products, systems or service programs is critical to obtain LEED® certification for a registered project, because the right products or service programmes can help meet the goals of green construction and ongoing operation and maintenance.

The choice of heating, ventilating and air conditioning (HVAC) products in particular can have a significant impact on LEED® certification, as the HVAC system directly impacts two categories that together influence 40% of the available points.

CUSTOMER BENEFITS

Designed to support Green Building Design

Overview of LEED® for new construction and major renovations

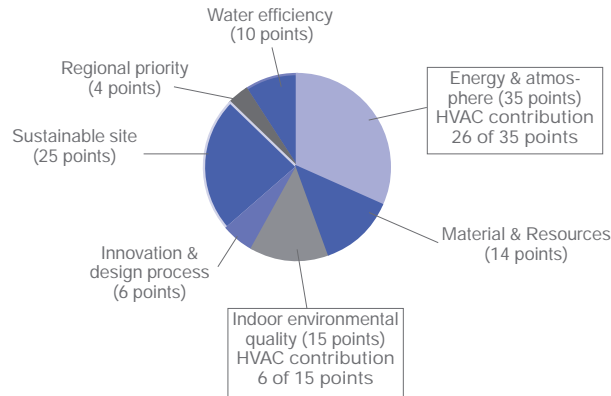

The new 30KAV units from Carrier can assist building owners to earn LEED® points in particular in the Energy & Atmosphere (EA) credit category and help address the following prerequisites and credit requirements:

- **EA prerequisite 2: Minimum energy Performance**
The 30KAV exceeds the energy efficiency requirements of ASHRAE 90,1-2007; therefore it complies with the prerequisite standard.
- **EA prerequisite 3: Fundamental Refrigerant Management**
The 30KAV does not use chlorofluorocarbon (CFC) refrigerants thus satisfying the prerequisite statement.
- **EA credit 1: Optimise energy performance (1 to 19 points):**
Points for this credit are assigned depending on the energy cost reduction virtually achievable by the new building, compared to ASHRAE 90,1-2007 reference. The 30KAV, which is designed for high performance especially during part load operation, contributes to reducing the energy consumption of the building and therefore helps in gaining points within this credit. In addition, the Carrier HAP (Hourly Analyses Program) can be used as an energy analyses program complying with the modeling requirements for this credit and produce reports that are easily transferable to LEED® templates.
- **EA credit 4: Enhanced refrigerant management (2 points):**
With this credit, LEED® awards systems that minimise the Ozone Depletion Potential (ODP) and Global Warming Potential (GWP) of the system. The 30KAV uses a reduced R134a charge and therefore contributes toward satisfying this credit under LEED®.

NOTE: This section describes the prerequisites and credit requirements in LEED® for New Construction and is directly related to the 30KAV. Other prerequisites and credit requirements are not directly and purely related to the air-conditioning unit itself, but more to the control of the complete HVAC system.

i-Vu®, Carrier's open control system, has features that can be valuable for:

- EA prerequisite 1: Fundamental commissioning of energy management system
- EA credit 3: Enhanced commissioning (2 points)
- EA credit 5: Measurements and verification (3 points).

NOTE: Products are not reviewed or certified under LEED®. LEED® credit requirements cover the performance of materials in aggregate, not the performance of individual products or brands. For more information on LEED®, visit www.usgbc.org.

TECHNICAL INSIGHTS

Touch Pilot control



- New innovative smart control features:
 - An intuitive and user-friendly, coloured, 7" interface
 - 10 languages available on choice: DE, EN, ES, FR, IT, NL, PT, TR, TU + one additional customer choice
 - Screen-shots with concise and clear information in local languages
 - Complete menu, customised for different users (end user, service personnel and Carrier-factory technicians)
 - Easy access to the controller box with inclined touch screen mounting to ensure legibility under any lighting conditions
 - Safe operation and unit setting: Password protection ensures that unauthorised people cannot modify any advanced parameters
 - Simple and "smart" intelligence uses data collection from the constant monitoring of all machine parameters to optimise unit operation
 - Night-mode: Cooling capacity management for reduced noise level.
- Energy management:
 - Innovative smart energy monitoring, providing users with smart data such as real time electric energy consumption, cooling capacity, and instantaneous and average seasonal energy efficiency ratios.
 - Internal time schedule clock controls chiller on/off times and operation at a second set-point
 - The DCT (Data Collection Tool) records the alarms history to simplify and facilitate service operations.

Remote management (standard)

- Units with Touch Pilot control can be easily accessed from the internet, using a PC with an Ethernet connection. This makes remote control quick and easy and offers significant advantages for service operations.
- Aquaforce with Greenspeed® Intelligence is equipped with an RS485 serial port that offers multiple remote control, monitoring and diagnostic possibilities. When networked with other Carrier equipment through the CCN (Carrier Comfort Network - proprietary protocol), all components form a HVAC system fully-integrated and balanced through one of the Carrier's network system products, like the Chiller System Manager or the Plant System Manager (optional).

- The 30KAV also communicates with other building management systems via optional communication gateways (BACnet, LON or JBus).
- The following commands/visualisations are possible from remote connection:
 - Start/Stop of the machine
 - Dual set-point management: Through a dedicated contact is possible to activate a second set-point (example, unoccupied mode)
 - Demand limit setting: To limit the maximum chiller capacity to a predefined value
 - Water pump control: These outputs control the contactors of one/two evaporator water pumps.
 - Water pumps changeover (only with hydraulic module options): These contacts are used to detect a water pump operation fault and automatically change over to the other pump.
 - Operation visualisation: Indication if the unit is operating or if it is in stand-by (no cooling load)
 - Alarm visualisation.

Remote management (EMM option)

- The Energy Management Module (EMM) offers extended remote control possibilities:
 - Room temperature: Permits set-point reset based on the building indoor air temperature (if Carrier thermostats are installed)
 - Set-point reset: Allows reset of the cooling set-point based on a 4-20 mA or 0-10 V signal
 - Demand limit: Permits limitation of the maximum chiller capacity based on 0-10 V signal
 - Demand limit 1 and 2: Closing of these contacts limits the maximum chiller capacity to two predefined values.
 - User safety: This contact can be used for any customer safety loop; opening the contact generates a specific alarm.
 - Ice storage end: When ice storage has finished, this input permits return to the second set-point (unoccupied mode).
 - Time schedule override: Closing of this contact cancels the programmed time schedule.
 - Out of service: This signal indicates that the chiller is completely out of service.
 - Chiller capacity: This analogue output (0-10 V) gives an immediate indication of the chiller capacity.
 - Alert indication: This volt-free contact indicates the necessity to carry out a maintenance operation or the presence of a minor fault.
 - Compressors running status: Set of outputs (as many as the compressors number) indicating which compressors are running.

TECHNICAL INSIGHTS

New generation of Carrier 06Z variable-speed twin screw compressor

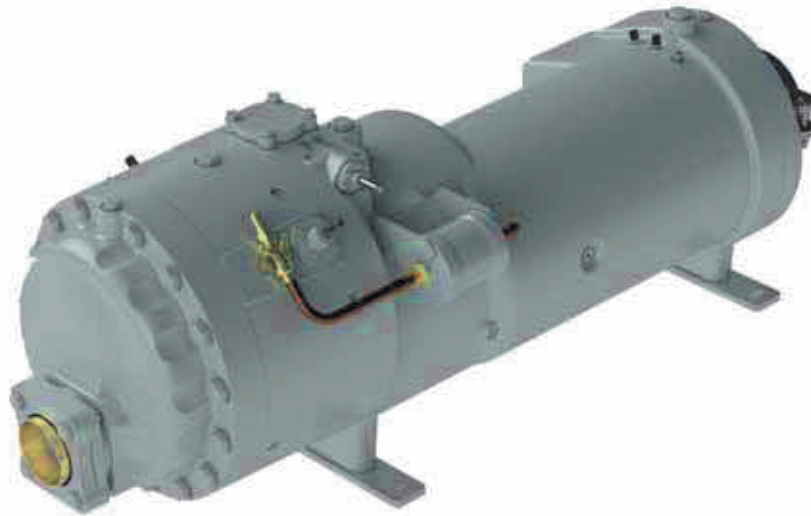

The new generation of 06Z variable-speed twin screw compressors benefits from Carrier's long experience in the development of twin-rotor screw compressors. The 06Z compressor design is based on the successful 06T screw compressor, core of the well-known Aquaforce series with a number of modifications to reduce noise level and improve the energy efficiency especially during part load operation.

- New 06Z twin screw compressor optimized for variable speed operation: elimination of the slide valve, built-in volume index control (Vi) valve for both optimal full and part load performance, high efficiency AC motor with stepless inverter control from 20% to 100%
- Separate air-cooled inverter drive for increased reliability
- New 06Z twin screw compressor design with Integrated Resonator Array (IRA) to reduce the sound level by up to 6 dB(A) when compared with previous 06T generation
- Integrated Check Valve for quiet shutdown
- Bearing life exceeding 100 000 hours.
- A dedicated oil separator is installed at the discharge of each compressor to ensure maximum oil return: Oil separates from refrigerant by gravity and returns to the low pressure side of the compressor without use of additional pumps.
- Volume index control (Vi) valve provides a reliable method of adjusting the compression ratio to better match system demand. It provides optimal performance regardless of operating condition
- Screw compressors work on the positive displacement principle to compress gas to a higher pressure. As a result, if there is an unusually high pressure in the condenser (due for example to coil fouling or operation in harsh climate) the compressor does not switch off, but continues operation at reduced capacity (unloaded mode).
- The silencer in the oil separator line (at the compressor outlet) considerably reduces discharge gas pulsations for much quieter operation.

TECHNICAL INSIGHTS

Novation® Heat Exchangers with Microchannel Coil Technology

Already utilised in the automobile and aeronautical industries for many years, the Novation™ Micro-Channel Heat Exchanger (MCHE) used in the Aquaforce is entirely made of aluminum. This one-piece concept significantly increases its corrosion resistance by eliminating the galvanic currents that are created when two different metals (copper and aluminum) come into contact in traditional heat exchangers.

- From the energy efficiency point-of-view the Novation® heat exchangers are approximately 10% more efficient than traditional coils and micro-channel coil technology allows a 40% reduction in the amount of refrigerant used in the chiller.
- The reduced depth of the Novation™ MCHE reduces air pressure losses by 50% and makes it much less susceptible to fouling (e.g. by sand). Cleaning of the Novation™ MCHE heat exchanger is very fast using a high pressure washer.
- To further enhance long-term performance, and protect coils from early deterioration, Carrier offers (as options) dedicated treatments for installations in corrosive environments.
 - The Novation™ MCHE with Enviro-Shield protection (option 262) is recommended for installations in moderately corrosive environments. The Enviro-Shield protection utilises corrosion inhibitors which actively arrest oxidation in case of mechanical damage.
 - The Novation™ MCHE with exclusive Super Enviro-Shield protection (option 263) is recommended for installations in corrosive environments. The Super Enviro-Shield protection consist of an extremely durable and flexible epoxy coating uniformly applied over all coil surfaces for complete isolation from the contaminated environment.
- After a total of more than 7,000 hours of testing following various test standards in UTC laboratories, the Carrier Novation® MCHE with Super Enviro-shield® coating appears to be the best-suited customer choice to minimize the harmful effects of corrosive atmospheres and ensure long equipment life.
 - Best corrosion resistance per ASTM B117/D610 test
 - Best heat transfer performance per Carrier Marine 1 test
 - Proven reliability per ASTM B117 test

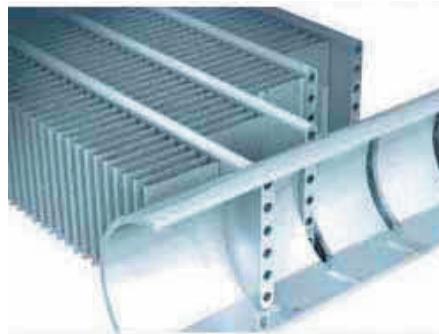

Coil Types (ranked by performance)	Visual Corrosion Evaluation	Heat Transfer Performance Degradation	Time to Failure	Test Campaign Conclusions
Super Enviro-shield® Novation™ MCHE	Very good	Very good	No coil leak	Best
Super Enviro-shield® Cu/Al coil	Very good	Good	No coil leak	Very good
Enviro-shield® Novation™ MCHE	Very good	Good	No coil leak	Very good
Al/Al coil	Very good	Good	No coil leak	Very good
Novation™ MCHE	Good	Good	No coil leak	Good
Cu/Cu coil	Good	Good	Leak	Acceptable
Blygold® Cu/Al coil	Good	Good	No coil leak	Acceptable
Precoat Cu/Al coil	Bad	Bad	No coil leak	Bad
Cu/Al coil	Bad	Bad	No coil leak	Bad

TECHNICAL INSIGHTS

New generation of Flying Bird VI fans with EC motors



The 30KAV utilizes Carrier's the 6th generation Flying Bird™ fan technology, engineered for maximum efficiency, super low noise, and wide operating range. The fan includes Carrier patented rotating shroud technology and back-swept blades with a unique wave-serration trailing edge inspired from nature.

It was designed and optimized for the 30KAV air management system configuration and heat exchanger technology and is offered with induction and EC motor options. The fan meets the latest European eco-design requirements for fan efficiency. The fan uses Carrier's robust and proven injection molded composite-thermoplastic construction.

OPTIONS

Options	No.	Description	Advantages	30KAV models
Low noise level	15	Sound absorbing & aesthetic compressor enclosure and oil separator acoustic treatment	Noise level reduction by 1 to 2 dB(A)	500-1100
Very low noise level	15LS	Sound absorbing & aesthetic compressor enclosure and oil separator, evaporator and suction line acoustic treatment, combined with low-speed fans	Noise level reduction in sensitive environments	500-1100
High ambient temperature	16	Electrical components sized for part load operation up to 55°C air ambient	Extended unit part-load operation up to 55°C ambient temperature	500-1100
EC fans	17	Unit equipped with EC fans	Enhances the unit energy efficiency	500-1100
IP54 control box	20A	Increased leak tightness of the unit	Protects the inside of the electrical box from dust, water and sand. In general this option is recommended for installations in polluted environments	500-1100
Grilles and enclosure panels	23	Metallic protection grilles and side enclosure panels	Improves aesthetics, protection against intrusion to the unit interior, coil and piping protection against impacts.	500-1100
Enclosure panels	23A	Side enclosure panels	Improves aesthetics and piping protection against impacts.	500-1100
Water exchanger frost protection	41A	Electric resistance heater on the water exchanger and discharge valve	water exchanger frost protection down to -20°C outside temperature	500-1100
Evaporator & hydraulic module frost protection	41B	Electric resistance heater on water exchanger, discharge valve and hydraulic module	Water exchanger and hydraulic module frost protection down to -20°C outside temperature	500-800
Master/slave operation	58	Unit equipped with supplementary water outlet temperature sensor kit to be field-installed allowing master/slave operation of two units connected in parallel	Optimised operation of two units connected in parallel operation with operating time equalisation	500-1100
Main disconnect switch with short-circuit protection	70D	Circuit breaker equipped with an external disconnect switch handle	Ensure protection of main disconnect switch and associated cables against short-circuits when building devices are not compliant	500-1100
Evap. and pumps with aluminum jacket	88A	Evaporator and pumps covered with an aluminum sheet for thermal insulation protection	Improved resistance to aggressive climate conditions	500-800
Service valve set	92	Liquid line valve (evaporator inlet), compressor suction and discharge line valves and economiser line valve	Allow isolation of various refrigerant circuit components for simplified service and maintenance	500-1100
Compressor discharge valves	93A	Shut-off valve on the compressor discharge piping	Simplified maintenance	500-1100
21 bar evaporator	104	Reinforced evaporator for extension of the maximum water-side service pressure to 21 bar (standard 10 bar)	Covers applications with a high water column evaporator side (typically high buildings)	500-1100
LP VSD dual-pump hydraulic mod.	116A	Dual low-pressure water pump with variable speed drive (VSD), pressure transducers. Multiple possibilities of water flow control. For more details, refer to the dedicated chapter.	Easy and fast installation (plug & play), significant pumping energy cost savings, tighter water flow control, improved system reliability	500-800
HP VSD dual-pump hydraulic mod.	116W	Dual high-pressure water pump with variable speed drive (VSD), pressure transducers. Multiple possibilities of water flow control. For more details, refer to the dedicated chapter.	Easy and fast installation (plug & play), significant pumping energy cost savings, tighter water flow control, improved system reliability	500-800
High Energy Efficiency	119	Additional condenser coil to improve unit energy efficiency	Enhances the unit energy efficiency performance	500-1100
High Energy Efficiency+	119+	Additional condenser coil plus EC fans to improve unit energy efficiency	Enhances the unit energy efficiency performance	500-1100
J-Bus gateway	148B	Bi-directional communication board complying with JBus protocol	Connects the unit by communication bus to a building management system	500-1100
Lon gateway	148D	Bi-directional communication board complying with Lon Talk protocol	Connects the unit by communication bus to a building management system	500-1100
Bacnet over IP	149	Bi-directional high-speed communication using BACnet protocol over Ethernet network (IP)	Easy and high-speed connection by ethernet line to a building management system. Allows access to multiple unit parameters	500-1100
Energy Management Module	156	EMM Control board with additional inputs/outputs. See Energy Management Module option chapter	Extended remote control capabilities (Set-point reset, ice storage end, demand limits, boiler on/off command...)	500-1100
Refrigerant leak detection	159	One refrigerant leak detector per circuit	Minimises refrigerant loss	500-1100

OPTIONS

Options	No.	Description	Advantages	30KAV models
Dual relief valves on 3-way valve	194	Three-way valve upstream of the relief valves on the evaporator and the oil separator	Valve replacement and inspection facilitated without refrigerant loss. Comforms to European standard EN378/BGVD4	500-1100
Compliance with Swiss regulations	197	Additional tests on the water heat exchangers: supply (additional of PED documents) supplementary certificates and test certifications	Conformance with Swiss regulations	500-1100
Compliance with Russian regulations	199	EAC certification	Conformance with Russian regulations	500-1100
Compliance with Australian regulations	200	Unit approved to Australian code	Conformance with Australian regulations	500-1100
Insulation of the evap. in/ out ref.lines	256	Thermal insulation of the evaporator entering/ leaving refrigerant lines with flexible, UV resistant insulation	Prevents condensation on the evaporator entering/leaving refrigerant lines	500-1100
Enviro-Shield anti-corrosion protection	262	Coating by conversion process which modifies the surface of the aluminum producing a coating that is integral to the coil. Complete immersion in a bath to ensure 100% coverage. No heat transfer variation, tested 4000 hours salt spray per ASTM B117	Improved corrosion resistance, recommended for use in moderately corrosive environments	500-1100
Super Enviro-Shield anti-corrosion protection	263	Extremely durable and flexible epoxy polymer coating applied on micro channel heat exchangers by electro coating process, final UV protective topcoat. Minimal heat transfer variation, tested 6000 hours constant neutral salt spray per ASTM B117, superior impact resistance per ASTM D2794	Improved corrosion resistance, recommended for use in extremely corrosive environments	500-1100
Welded evaporator connection kit	266	Victaulic piping connections with welded joints	Easy installation	500-1100
Evaporator with aluminum jacket	281	Evaporator covered with an aluminum sheet for thermal insulation protection	Improved resistance to aggressive climate conditions	500-1100
EMC class. C2, as per EN 61800-3	282	Additional RFI filters on the unit power line	Reduces electromagnetic interference. Increase the variable frequency drive (VFD) immunity level according to first environment (so called, residential environment) requirements and allows compliance with emissions level required in category C2	500-1100
230V electrical plug	284	230V AC power supply source provided with plug socket and transformer (180 VA, 0,8 Amps)	Permits connection of a laptop or an electrical device during unit commissioning or servicing	500-1100
Expansion tank	293	6 bar expansion tank integrated in the hydraulic module (requires hydraulic module option)	Easy and fast installation (plug & play), & Protection of closed water systems from excessive pressure	500-800
Carrier Connect link (only European distributor company)	298	3G router board NOTE 1: require option 149 NOTE 2: when more than one machine is installed on site, only one of them shall be equipped with option 298 while all of them must be equipped with option 149 NOTE 3: if the Carrier® PlantCTRL™ is on site, option 298 shall be integrated in the Carrier® PlantCTRL™ while option 149 is still mandatory for each single unit.	Enabler for Carrier Connect service offer	500-1100
Variable Water Flow control	299	hydraulic control function package that permits control of the water flow rate based on different possible logics (at customer choice): constant ΔT , constant outlet pressure and "fixed-speed" control	When variable-speed pumps on the primary circuit, the VWF control modulates flow rate through the evaporator, minimising pump consumption while ensuring safe/optimised chiller operation	500-1100
Compliance with UAE regulation	318	Additional label on the unit with rated power input, rated current and EER following AHRI 550/590	Compliance with ESMA standard UAE 5010-5 :2014.	500-1100
Compliance with Qatar regulation	319	Specific nameplate on the unit with power supply 415 V+/-6%	Compliance with KAHRAMAA regulation in Qatar.	500-1100

PHYSICAL DATA

Standard units and Units with EC fans option (17)

30KAV		500	550	600	650	720	800	900	1000	1100	
Cooling											
Standard unit		Nominal capacity	kW								
Full load performances*	CA1	EER	3,00	2,91	3,14	2,98	3,19	3,03	3,07	2,98	3,05
		Eurovent class	B	B	A	B	A	B	B	B	B
Standard unit		SEER _{12/7°C} Comfort low temp.	kWh/kWh								
Seasonal energy efficiency		SEER _{12/7°C} Comfort medium temp.	4,97	4,95	5,23	5,21	5,34	5,15	5,24	5,13	5,27
		SEPR _{12/7°C} Process high temp.	196	195	206	205	211	203	207	202	208
		SEER _{23/18°C} Comfort medium temp.	6,25	6,28	6,73	6,70	6,96	6,30	6,66	6,47	6,81
		SEPR _{12/7°C} Process high temp.	5,81	5,77	6,49	6,37	6,54	5,63	6,17	5,70	6,03
Unit + option 17		SEER _{12/7°C} Comfort low temp.	kWh/kWh								
Seasonal energy efficiency		SEER _{12/7°C} Comfort medium temp.	5,02	5,00	5,29	5,27	5,42	5,21	5,32	5,20	5,35
		SEPR _{12/7°C} Process high temp.	198	197	209	208	214	205	210	205	211
		SEER _{23/18°C} Comfort medium temp.	6,34	6,36	6,84	6,80	7,08	6,39	6,78	6,59	6,94
		SEPR _{12/7°C} Process high temp.	5,86	5,81	6,55	6,43	6,62	5,69	6,25	5,76	6,10
Sound levels											
Standard unit											
Sound power ⁽¹⁾			dB(A)								
Sound pressure at 10 m ⁽²⁾			dB(A)								
Unit + option 15⁽³⁾			dB(A)								
Sound power ⁽¹⁾			dB(A)								
Sound pressure at 10 m ⁽²⁾			dB(A)								
Unit + option 15LS⁽³⁾			dB(A)								
Sound power ⁽¹⁾			dB(A)								
Sound pressure at 10 m ⁽²⁾			dB(A)								
Dimensions											
Standard unit											
Length			mm								
Width			mm								
Height			mm								
Unit + options 116A/116W⁽³⁾			mm								
Length			mm								
Operating weight⁽⁴⁾											
Standard unit			kg								
Unit + options 116A/116W ⁽³⁾			kg								
Compressors											
Inverter driven 06Z twin screw compressor with AC motor											
Circuit A		Quantity									
Circuit B		Quantity									
Unit minimum capacity ⁽⁵⁾		%									
Refrigerant⁽⁴⁾											
R134a (GWP=1430, ODP=0)											
Circuit A		kg									
		teqCO ₂									
Circuit B		kg									
		teqCO ₂									

* In accordance with standard EN14511-3:2013.
 CA1 Cooling mode conditions: Evaporator water entering/leaving temperature 12°C/7°C, outside air temperature 35°C, evaporator fouling factor 0 m².K/W
 Ij_{s cool,12/7°C} & SEPR_{12/7°C} Applicable Ecodesign regulation: (EU) No 2016/2281
 (1) in dB ref=10⁻¹² W, 'A' weighted. Declared dual-number noise emission values in accordance with ISO 4871 with an associated uncertainty of +/-3dB(A). Measured in accordance with ISO 9614-1 and certified by Eurovent.
 (2) In dB ref 20µPa, 'A' weighted. Declared dual-number noise emission values in accordance with ISO 4871 with an associated uncertainty of +/-3dB(A). For information, calculated from the sound power Lw(A).
 (3) Options: 15=Low noise level; 15LS=Very low noise level; 116A=LP VSD dual-pump hydraulic mod.; 116W=HP VSD dual-pump hydraulic mod.
 (4) Values are guidelines only. Refer to the unit name plate.
 (5) For standard conditions. Depending on operating conditions, unit might have a different minimum capacity or cycle.



Eurovent certified values

PHYSICAL DATA

Standard units and Units with EC fans option (17)

30KAV		500	550	600	650	720	800	900	1000	1100
Oil		SW220								
Circuit A	l	20	20	20	20	20	20	20	20	20
Circuit B	l	20	20	20	20	20	20	20	20	20
Unit control		Touch Pilot with 7 inch coloured touch screen interface								
Languages		10 languages (DE, EN, ES, FR, IT, NL, PT, TR, TU + one on customer choice)								
Smart energy metering		Standard feature								
Wireless connectivity		Option								
Expansion valve		Electronic expansion valve								
Air heat exchanger		Novation™ Micro Channel Heat Exchanger								
Fans										
Standard unit		Inverter driven Flying Bird™ VI fans with AC motor								
Unit + option 17		Inverter driven Flying Bird™ VI fans with EC motor								
Quantity		6	6	8	8	10	10	12	12	14
Maximum total air flow	l/s	35580	35580	47440	47440	59300	59300	71160	71160	83020
Maximum rotation speed	r/s	16,0	16,0	16,0	16,0	16,0	16,0	16,0	16,0	16,0
Maximum total air flow + option 15LS ⁽³⁾	l/s	28920	26100	41600	43200	56000	50000	67200	57840	72800
Maximum rotation speed + option 15LS ⁽³⁾	r/s	13,2	12,0	14,2	14,7	15,2	13,7	15,2	13,2	14,2
Water heat exchanger		Flooded shell and tube heat exchanger								
Water volume	l	83	88	96	100	115	126	144	165	183
Max. water-side operating pressure without hydraulic module	kPa	1000	1000	1000	1000	1000	1000	1000	1000	1000
Hydraulic module (option)		Double pump, screen filter, relief valve, water drain valve, pressure sensors, expansion tank (option), heaters (option)								
Pump		Inverter driven dual pumps with AC motor								
Expansion vessel volume	l	80	80	80	80	80	80	-	-	-
Max. water-side operating pressure	kPa	400	400	400	400	400	400	-	-	-
Water connections		Victaulic® type								
Without options 116A/116W⁽³⁾										
Connections	pouces	5	5	6	6	6	6	8	8	8
Outside tube diameter	mm	141,3	141,3	168,3	168,3	168,3	168,3	219,1	219,1	219,1
With options 116A/116W⁽³⁾										
Connections	pouces	5	5	5	5	5	5	-	-	-
Outside tube diameter	mm	141,3	141,3	141,3	141,3	141,3	141,3	-	-	-
Casing paint		Colour code RAL 7035								

(3) Options: 15=Low noise level ; 15LS=Very low noise level ; 116A=LP VSD dual-pump hydraulic mod. ; 116W=HP VSD dual-pump hydraulic mod.
(5) For standard conditions. Depending on operating conditions, unit might have a different minimum capacity or cycle.

PHYSICAL DATA

Units with High energy efficiency option (119) and High energy efficiency+ option (119+)

30KAV options 119/119+			500	550	600	650	720	800	900	1000	1100		
Cooling													
Unit + option 119+	CA1	Nominal capacity	kW	517	575	611	661	731	819	907	1010	1097	
		Full load performances*	EER	kW/kW	3,49	3,41	3,42	3,32	3,37	3,35	3,29	3,30	3,25
			Eurovent class		A	A	A	A	A	A	A	A	A
Unit + option 119	Seasonal energy efficiency	SEER _{12/7°C} Comfort low temp.	kWh/kWh	5,32	5,32	5,40	5,38	5,44	5,36	5,31	5,29	5,33	
		I _{js cool} _{12/7°C}	%	210	210	213	212	215	212	209	209	210	
		SEER _{23/18°C} Comfort medium temp.	kWh/kWh	6,94	6,97	7,03	7,00	7,15	6,76	6,84	6,74	6,94	
		SEPR _{12/7°C} Process high temp.	kWh/kWh	7,03	6,92	6,97	6,83	6,87	6,58	6,55	6,49	6,47	
Unit + option 119+	Seasonal energy efficiency	SEER _{12/7°C} Comfort low temp.	kWh/kWh	5,43	5,43	5,50	5,47	5,53	5,47	5,41	5,40	5,43	
		I _{js cool} _{12/7°C}	%	214	214	217	216	218	216	213	213	214	
		SEER _{23/18°C} Comfort medium temp.	kWh/kWh	7,12	7,15	7,19	7,16	7,32	6,92	6,99	6,92	7,12	
		SEPR _{12/7°C} Process high temp.	kWh/kWh	7,14	7,03	7,07	6,94	6,98	6,68	6,66	6,60	6,57	
Sound levels													
Unit + option 119+													
		Sound power ⁽¹⁾	dB(A)	96	96	97	98	99	98	100	98	100	
		Sound pressure at 10 m ⁽²⁾	dB(A)	63	63	64	66	66	65	67	65	67	
Unit + options 15 + 119+⁽³⁾													
		Sound power ⁽¹⁾	dB(A)	95	95	94	96	97	96	98	98	98	
		Sound pressure at 10 m ⁽²⁾	dB(A)	62	62	62	64	64	64	65	65	65	
Unit + options 15LS + 119+⁽³⁾													
		Sound power ⁽¹⁾	dB(A)	90	91	91	92	94	92	94	93	94	
		Sound pressure at 10 m ⁽²⁾	dB(A)	57	58	58	59	61	60	61	60	61	
Dimensions													
Unit + option 119/119+													
		Length	mm	6735	6735	6735	6735	7925	9120	9120	10305	10305	
		Width	mm	2253	2253	2253	2253	2253	2253	2253	2253	2253	
		Height	mm	2297	2297	2297	2297	2297	2297	2297	2297	2297	
Unit + option 119/119+ + options 116A/116W⁽³⁾													
		Length	mm	6735	6735	6735	6735	7925	9120	-	-	-	
Operating weight⁽⁴⁾													
		Unit + option 119+	kg	5570	5583	5606	5632	6075	6879	7026	7813	7875	
		Unit + options 116A/116W ⁽³⁾ + 119+	kg	5979	6093	6081	6107	6678	7524	-	-	-	
Compressors													
Inverter driven 06Z twin screw compressor with AC motor													
		Circuit A	Quantity	1	1	1	1	1	1	1	1	1	
		Circuit B	Quantity	1	1	1	1	1	1	1	1	1	
		Unit minimum capacity ⁽⁵⁾	%	13	12	11	10	10	10	10	11	10	
Refrigerant⁽⁴⁾													
R134a (GWP=1430, ODP=0)													
Circuit A			kg	65	65	63	70	74	93	102	103	106	
			teqCO ₂	93	93	90	100	106	133	146	147	152	
Circuit B			kg	66	66	64	71	75	75	82	104	107	
			teqCO ₂	94	94	92	102	107	107	117	149	153	

* In accordance with standard EN14511-3:2013.
 CA1 Cooling mode conditions: Evaporator water entering/leaving temperature 12°C/7°C, outside air temperature 35°C, evaporator fouling factor 0 m².K/W
 I_{js cool}_{12/7°C} & SEPR_{12/7°C} Applicable Ecodesign regulation: (EU) No 2016/2281
 (1) in dB ref=10⁻¹² W, 'A' weighted. Declared dual-number noise emission values in accordance with ISO 4871 with an associated uncertainty of +/-3dB(A). Measured in accordance with ISO 9614-1 and certified by Eurovent.
 (2) In dB ref 20µPa, 'A' weighted. Declared dual-number noise emission values in accordance with ISO 4871 with an associated uncertainty of +/-3dB(A). For information, calculated from the sound power L_w(A).
 (3) Options: 15=Low noise level; 15LS=Very low noise level; 116A=LP VSD dual-pump hydraulic mod.; 116W=HP VSD dual-pump hydraulic mod.
 (4) Values are guidelines only. Refer to the unit name plate.
 (5) For standard conditions. Depending on operating conditions, unit might have a different minimum capacity or cycle.



Eurovent certified values

PHYSICAL DATA

Units with High energy efficiency option (119) and High energy efficiency+ option (119+)

30KAV options 119/119+	500	550	600	650	720	800	900	1000	1100	
Oil	SW220									
Circuit A	I	20	20	20	20	20	20	20	20	20
Circuit B	I	20	20	20	20	20	20	20	20	20
Unit control	Touch Pilot with 7 inch colored touch screen interface									
Languages	10 languages (DE, EN, ES, FR, IT, NL, PT, TR, TU + one on customer choice)									
Smart energy metering	Standard feature									
Wireless connectivity	Option									
Expansion valve	Electronic expansion valve									
Air heat exchanger	Novation™ Micro Channel Heat Exchanger									
Fans										
Unit + option 119	Inverter driven Flying Bird™ VI fans with AC motor									
Unit + option 119+	Inverter driven Flying Bird™ VI fans with EC motor									
Quantity		10	10	10	10	12	14	14	16	16
Maximum total air flow	l/s	59300	59300	59300	59300	71160	83020	83020	94880	94880
Maximum rotation speed	r/s	16,0	16,0	16,0	16,0	16,0	16,0	16,0	16,0	16,0
Maximum total air flow + option 15LS ⁽³⁾	l/s	44700	43500	52000	52000	64800	67480	75600	74080	83200
Maximum rotation speed + option 15LS ⁽³⁾	r/s	12,3	12	14,2	14,2	14,7	13,2	14,7	12,7	14,2
Water heat exchanger	Flooded shell and tube heat exchanger									
Water volume	l	83	88	96	100	115	126	144	165	183
Max. water-side operating pressure without hydraulic module	kPa	1000	1000	1000	1000	1000	1000	1000	1000	1000
Hydraulic module (option)	Double pump, screen filter, relief valve, water drain valve, pressure sensors, expansion tank (option), heaters (option)									
Pump	Inverter driven dual pumps with AC motor									
Expansion vessel volume	l	80	80	80	80	80	80	-	-	-
Max. water-side operating pressure	kPa	400	400	400	400	400	400	-	-	-
Water connections	Victaulic® type									
Without options 116A/116W⁽³⁾										
Connections	pouces	5	5	6	6	6	6	8	8	8
Outside tube diameter	mm	141,3	141,3	168,3	168,3	168,3	168,3	219,1	219,1	219,1
With options 116A/116W⁽³⁾										
Connections	pouces	5	5	5	5	5	5	-	-	-
Outside tube diameter	mm	141,3	141,3	141,3	141,3	141,3	141,3	-	-	-
Casing paint	Colour code RAL 7035									

(3) Options: 15=Low noise level ; 15LS=Very low noise level ; 116A=LP VSD dual-pump hydraulic mod. ; 116W=HP VSD dual-pump hydraulic mod.
 (5) For standard conditions. Depending on operating conditions, unit might have a different minimum capacity or cycle.

ELECTRICAL DATA

Standard units

30KAV		500	550	600	650	720	800	900	1000	1100
Power circuit supply										
Nominal voltage	V-ph-Hz	400-3-50								
Voltage range	V	360-440								
Control circuit supply										
24 V via internal transformer										
Maximum operating input power⁽¹⁾										
Standard unit	kW	230	251	281	295	329	370	416	458	502
Unit + option 16	kW	248	270	300	315	352	402	451	502	551
Power factor at maximum power^{(1) (2)}										
0.91-0.93										
Displacement Power Factor (Cos Phi)										
>0.98										
Total harmonic distortion (THDi)^{(1) (2)}										
%										
35-45										
Nominal operating current draw⁽³⁾										
Standard unit	A	265	297	316	340	362	422	468	524	564
Maximum operating current draw (Un)⁽¹⁾										
Standard unit	A	358	390	436	459	511	575	646	712	780
Unit + option 16	A	385	420	466	490	546	625	701	781	856
Maximum operating current draw (Un-10%)										
Standard unit	A	392	426	477	502	545	629	688	779	831
Unit + option 16	A	422	459	510	537	582	684	747	855	912
Start-up current										
Not Applicable (less than the operating current)										

(1) Values obtained at operation with maximum operating power input (data given on the unit nameplate)

(2) May vary depending on short-circuit ratio of the installation

(3) Standardised EUROVENT conditions, water-cooled exchanger water inlet/outlet = 12°C/7°C, outdoor air temperature = 35°C.

Units with option High energy efficiency (119) and option High energy efficiency+ (119+)

30KAV options 119/119+		500	550	600	650	720	800	900	1000	1100
Power circuit supply										
Nominal voltage	V-ph-Hz	400-3-50								
Voltage range	V	360-440								
Control circuit supply										
24 V via internal transformer										
Maximum operating input power⁽¹⁾										
Unit + option 119	kW	228	254	264	286	319	362	401	446	484
Unit + option 119+	kW	226	252	261	283	316	359	397	442	479
Unit + option 119 + option 16	kW	245	273	283	306	342	394	436	490	533
Unit + option 119+ + option 16	kW	243	271	280	303	339	391	432	486	528
Power factor at maximum power^{(1) (2)}										
0.91-0.93										
Displacement Power Factor (Cos Phi)										
>0.98										
Total harmonic distortion (THDi)^{(1) (2)}										
%										
35-45										
Nominal operating current draw⁽³⁾										
Unit + option 119	A	228	260	285	318	346	374	441	466	535
Unit + option 119+	A	225	257	281	314	341	369	435	460	528
Maximum operating current draw (Un)⁽¹⁾										
Unit + option 119	A	355	395	410	445	495	563	623	693	752
Unit + option 119+	A	352	392	406	441	490	558	617	687	745
Unit + option 119 + option 16	A	382	425	440	476	530	613	678	762	828
Unit + option 119+ + option 16	A	379	422	436	472	525	608	672	756	821
Maximum operating current draw (Un-10%)										
Unit + option 119	A	387	425	448	485	533	614	673	757	811
Unit + option 119+	A	384	422	444	481	528	609	667	751	804
Unit + option 119 + option 16	A	417	458	481	520	570	669	732	833	892
Unit + option 119+ + option 16	A	414	455	477	516	565	664	726	827	885
Start-up current										
Not Applicable (less than the operating current)										

(1) Values obtained at operation with maximum operating power input (data given on the unit nameplate)

(2) May vary depending on short-circuit ratio of the installation

(3) Standardised EUROVENT conditions, water-cooled exchanger water inlet/outlet = 12°C/7°C, outdoor air temperature = 35°C.

DIMENSIONS/CLEARANCES

30KAV 500 & 550 without Hydraulic module

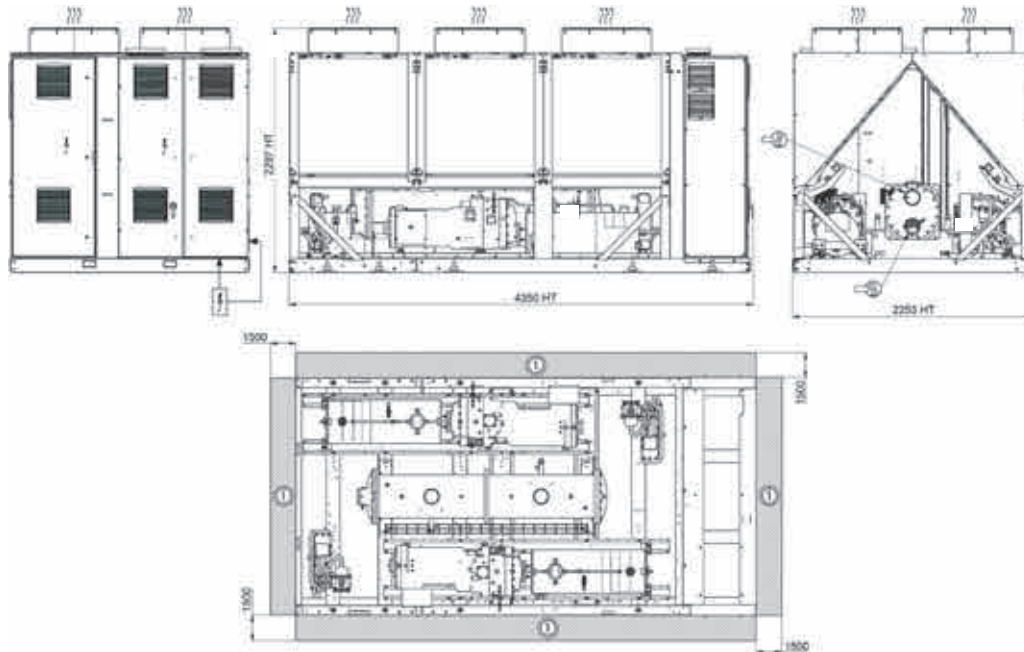

30KAV 500 & 550 with Hydraulic module

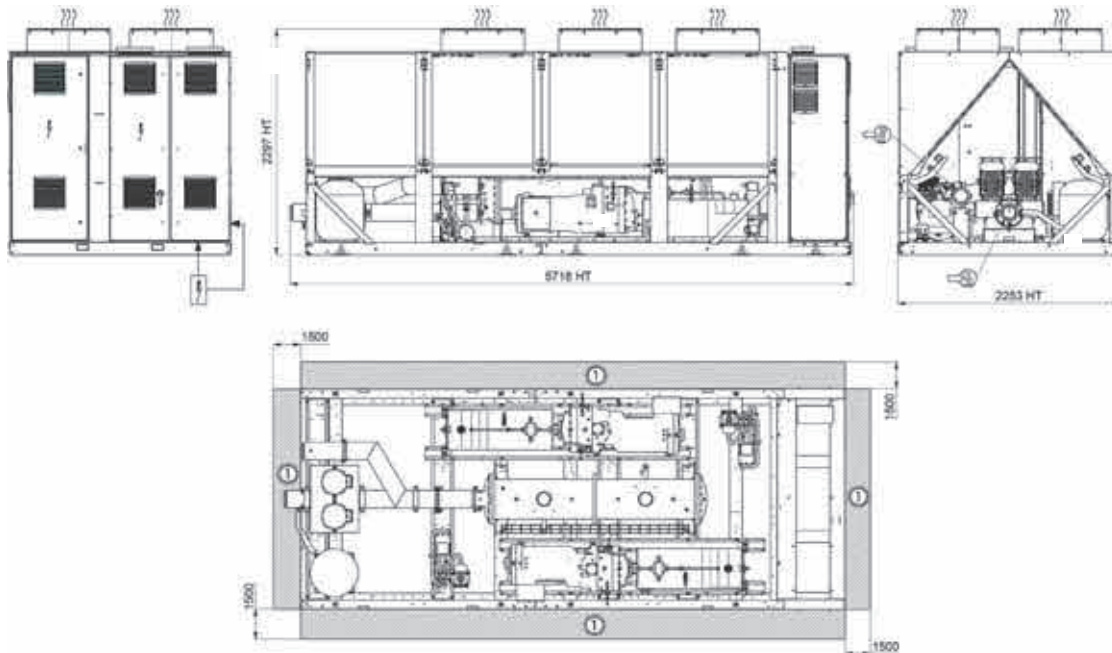

Legend

All dimensions are given in mm.

- Required clearances for maintenance (see note)
- Water inlet for standard unit
- Water outlet for standard unit
- Air outlet – do not obstruct
- Power electrical connection

NOTES:

Drawings are not contractually binding.

Before designing an installation, consult the certified dimensional drawings, available on request.

For the positioning of the fixing points, weight distribution and center of gravity coordinates please refer to the dimensional drawings.

If any unit(s) are close to walls, please refer to chapter “Distance to the wall” of this document to determine the space required.

DIMENSIONS/CLEARANCES

30KAV 600 & 650 without Hydraulic module

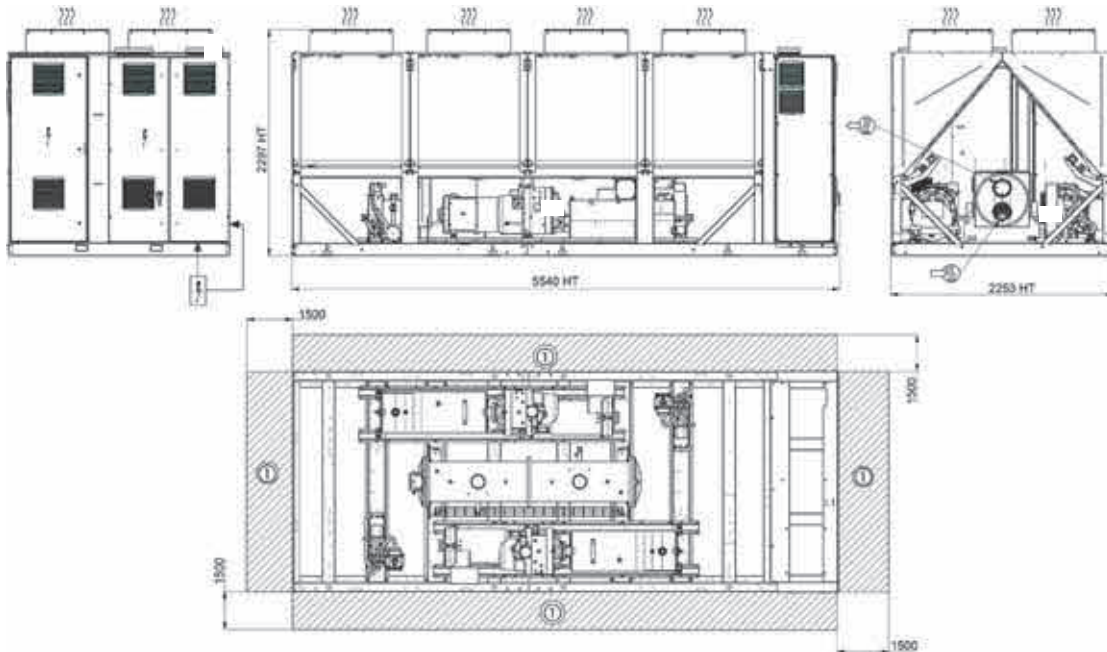

30KAV 600 & 650 with Hydraulic module

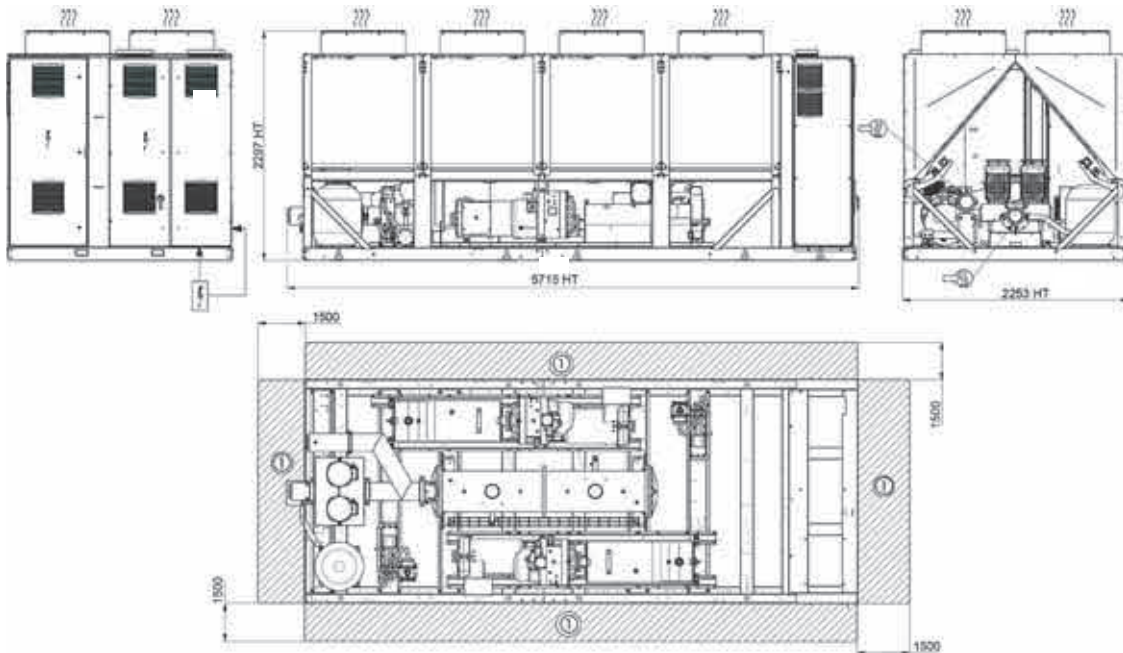

Legend

All dimensions are given in mm.

- Required clearances for maintenance (see note)
- Water inlet for standard unit
- Water outlet for standard unit
- Air outlet – do not obstruct
- Power electrical connection

NOTES:

Drawings are not contractually binding.

Before designing an installation, consult the certified dimensional drawings, available on request.

For the positioning of the fixing points, weight distribution and center of gravity coordinates please refer to the dimensional drawings.

If any unit(s) are close to walls, please refer to chapter “Distance to the wall” of this document to determine the space required.

DIMENSIONS/CLEARANCES

30KAV 500, 550, 600 & 650 opt. 119/119+ 30KAV 720 & 800 without Hydraulic module

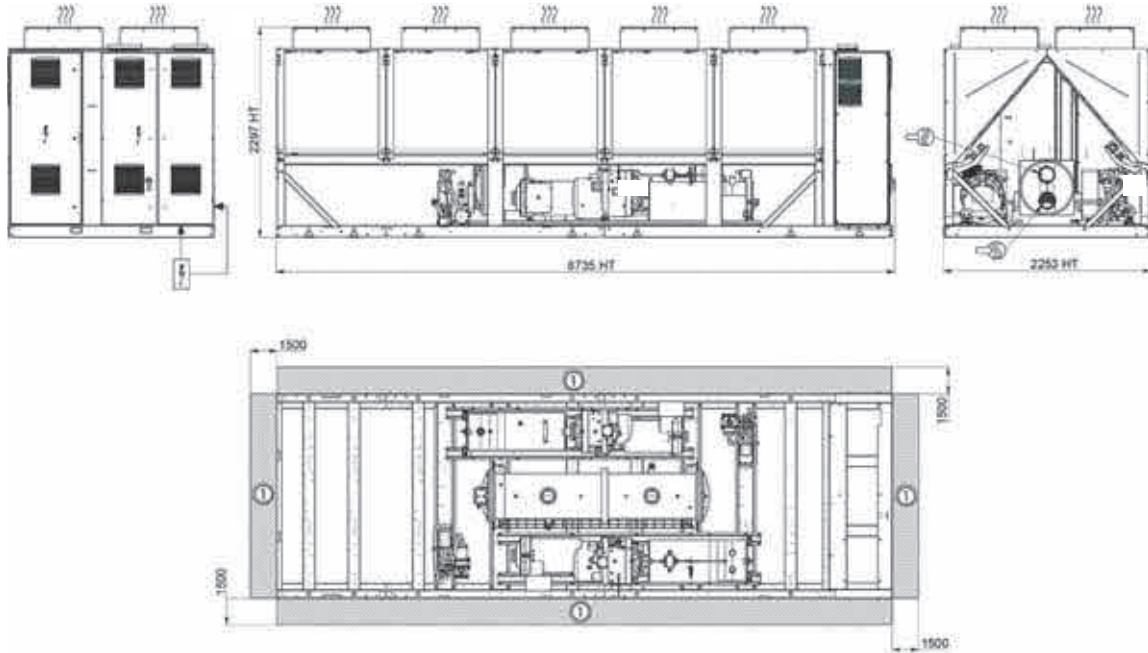

30KAV 500, 550, 600 & 650 opt. 119/119+ & 30KAV 720 & 800 with Hydraulic module

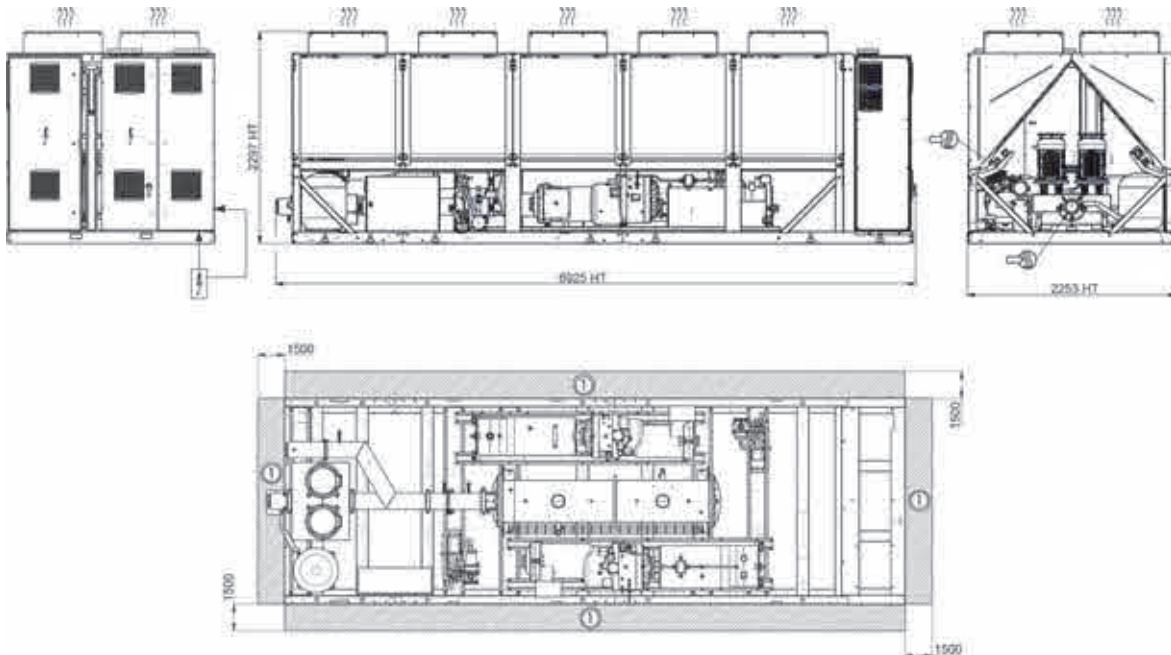

Legend

All dimensions are given in mm.

- Required clearances for maintenance (see note)
- Water inlet for standard unit
- Water outlet for standard unit
- Air outlet – do not obstruct
- Power electrical connection

NOTES:

Drawings are not contractually binding.

Before designing an installation, consult the certified dimensional drawings, available on request.

For the positioning of the fixing points, weight distribution and center of gravity coordinates please refer to the dimensional drawings.

If any unit(s) are close to walls, please refer to chapter "Distance to the wall" of this document to determine the space required.

DIMENSIONS/CLEARANCES

30KAV 720 opt. 119/119+ 30KAV 900 & 1000 without Hydraulic module

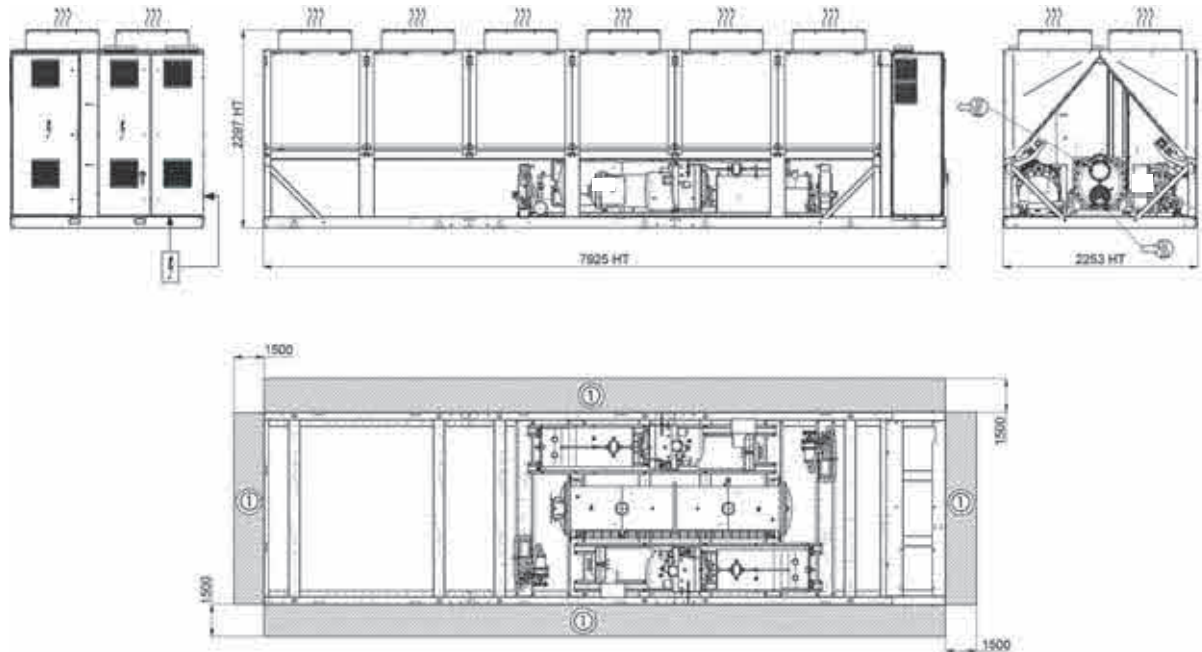

30KAV 720 opt. 119/119+ with Hydraulic module

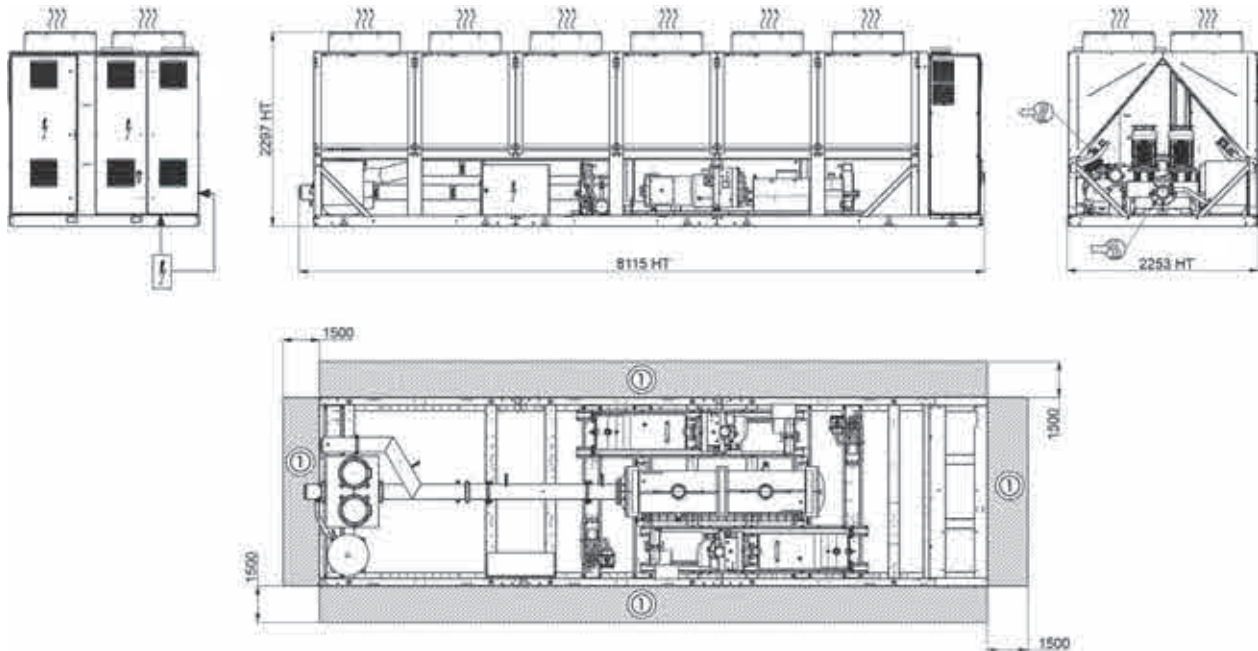

Legend

All dimensions are given in mm.

- Required clearances for maintenance (see note)
- Water inlet for standard unit
- Water outlet for standard unit
- Air outlet – do not obstruct
- Power electrical connection

NOTES:

Drawings are not contractually binding.

Before designing an installation, consult the certified dimensional drawings, available on request.

For the positioning of the fixing points, weight distribution and center of gravity coordinates please refer to the dimensional drawings.

If any unit(s) are close to walls, please refer to chapter “Distance to the wall” of this document to determine the space required.

DIMENSIONS/CLEARANCES

30KAV 800 & 900 opt. 119/119+ 30KAV 1100, without Hydraulic module

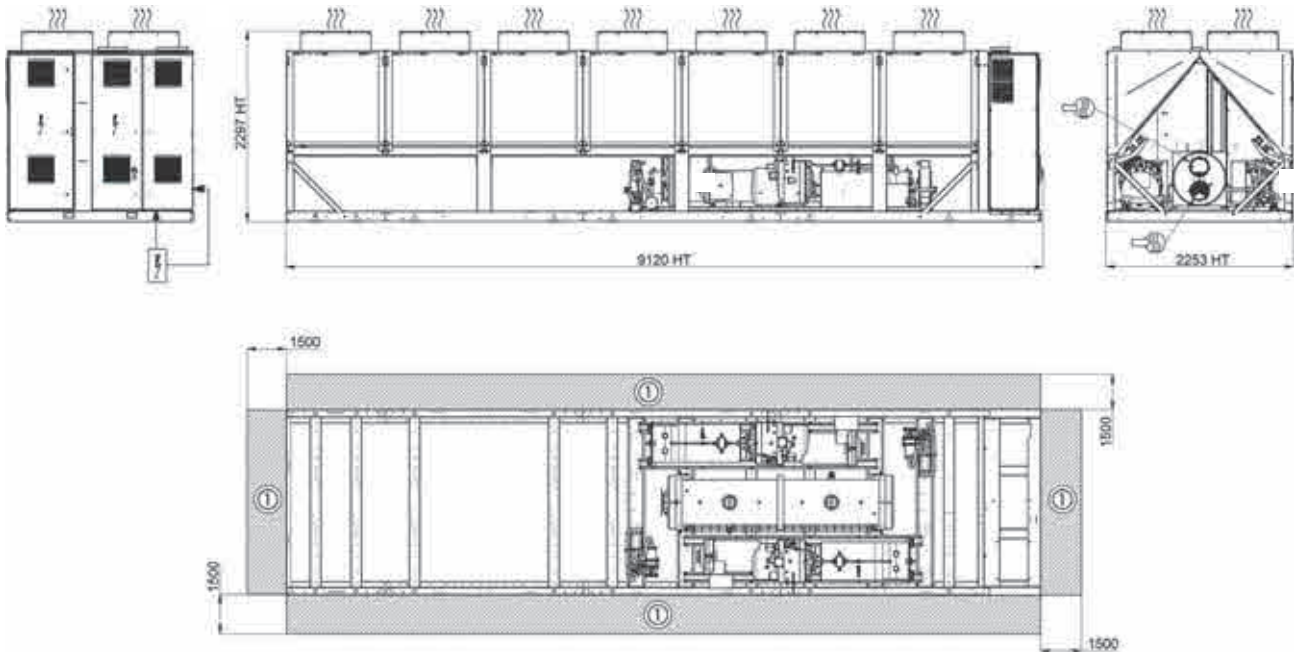

30KAV 800 opt. 119/119+ with Hydraulic module

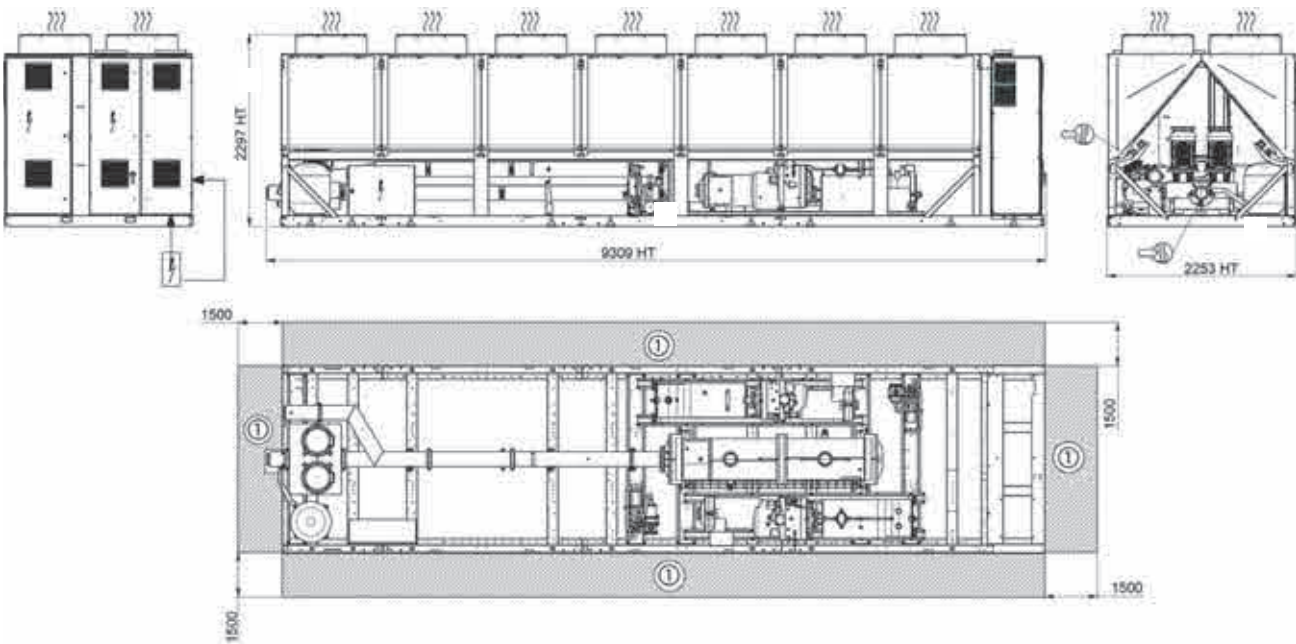

Legend

All dimensions are given in mm.

- a Required clearances for maintenance (see note)
- Water inlet for standard unit
- Water outlet for standard unit
- Air outlet – do not obstruct
- Power electrical connection

NOTES:

Drawings are not contractually binding.

Before designing an installation, consult the certified dimensional drawings, available on request.

For the positioning of the fixing points, weight distribution and center of gravity coordinates please refer to the dimensional drawings.

If any unit(s) are close to walls, please refer to chapter “Distance to the wall” of this document to determine the space required.

DIMENSIONS/CLEARANCES

30KAV 1000 & 1100 opt. 119/119+

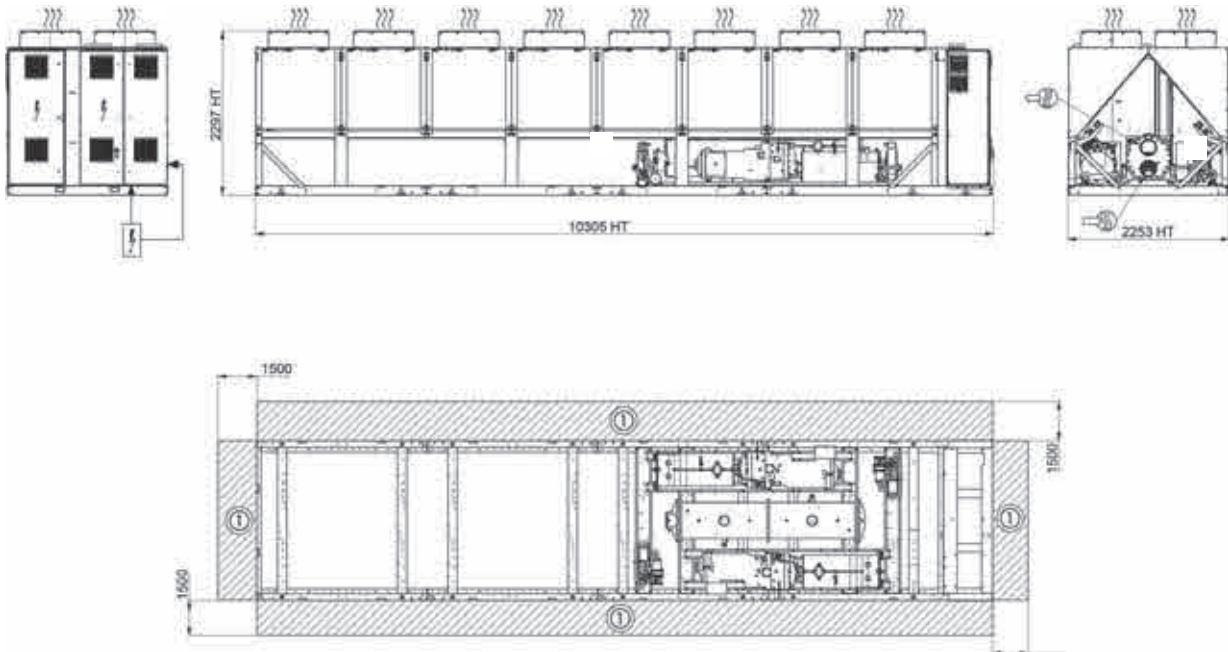

Legend

All dimensions are given in mm.

- Required clearances for maintenance (see note)
- Water inlet for standard unit
- Water outlet for standard unit
- Air outlet – do not obstruct
- Power electrical connection

NOTES:

Drawings are not contractually binding.

Before designing an installation, consult the certified dimensional drawings, available on request.

For the positioning of the fixing points, weight distribution and center of gravity coordinates please refer to the dimensional drawings.

If any unit(s) are close to walls, please refer to chapter “Distance to the wall” of this document to determine the space required.

Multiple chiller installation

It is recommended to install multiple chillers in a single row, arranged as shown in the example below, to avoid recycling of warm air from one unit to another.



If the situation at the site does not permit this arrangement, contact your Carrier distributor to evaluate the various possible arrangements. In certain situations an accessory (supplied loose at the time of purchase) can be added.

Distance to the wall

To ensure correct operation for most cases:

- If $h < H$ (2,3 m), S minimum = 3 m
- If $h > H$ ou $S < 3$ m, contact your Carrier distributor to evaluate the various possible arrangements. In certain situations an accessory (supplied loose at the time of purchase) can be added.

