

WATER-COOLED VARIABLE-SPEED SCREW CHILLERS



- Low energy consumption
- High reliability
- Easy and fast installation
- Minimised operating sound levels
- Environmental care
- Designed to support green building design

COOLING

30XW-V

Nominal cooling capacity 587-1741 kW
 Nominal heating capacity 648-1932 kW

The 30XW-V water-sourced units are the premium solution for commercial and industrial applications where installers, consultants and building owners require maximum quality and optimal performances, especially at part load.

The 30XW-V unit are designed to meet current and future requirements in terms of energy efficiency, versatility and compactness. They feature exclusive inverter-driven screw compressors - an evolution of the proven traditional Carrier twin-rotor screw compressor design. Other features include:

- the new Touch Pilot control
- mechanically cleanable flooded heat exchangers
- refrigerant R-134a

The 30XW-V/30XWHV range is split into two versions:

- 30XW-V for air conditioning applications
- 30XWHV for heating applications

As standard, the unit can provide an evaporator leaving water temperature down to 3.3°C, and when operating as a heat pump, it can deliver up to 50°C on the condenser side.



CARRIER participates in the ECP programme for LCP/HP
 Check ongoing validity of certificate:
www.eurovent-certification.com

CUSTOMER BENEFITS

Low energy consumption

- The 30XW-V/30XWHV was designed for high performance both at full load and at part load.
 - Eurovent certified values per EN14511-3:2013: SEPR up to 8.07 and SEER up to 8.43
- High energy efficiency
 - Inverter-driven twin-rotor screw compressors allow precise capacity matching of building load changes and significantly reduce unit power input, especially at part-load.
 - Flooded multi-pipe heat exchangers for increased heat exchange efficiency.
 - Electronic expansion device permits operation at a lower condensing pressure and improved utilisation of the evaporator heat exchange surface.
- Optimised electrical performance
 - All 30XW-V/30XWHV units comply with class 3 of standard EN61800-3. Category C3 refers to industrial environments. With option 282 category C2 compliance is possible.
 - Inverter-driven motors ensure negligible start-up current (value is lower than the maximum unit current draw)

High reliability

- The 30XW-V and 30XWHV ranges offer increased global performance as well as Carrier's acclaimed product quality and reliability. Major components are selected and tested to minimize failures possibility, as well as many design choices have been taken in this perspective.
- Inverter-driven screw compressors
 - Industrial-type screw compressors with oversized bearings and motor cooled by suction gas.
 - The inverter is optimised for each compressor motor to ensure reliable operation and easy maintenance.
 - All compressor components are easily accessible on site minimising down-time.
- Refrigerant circuits
 - Two independent refrigerant circuits (from 1000 kW upwards); the second one automatically takes over, if the first one develops a fault, maintaining partial cooling under all circumstances.
- Evaporator
 - Electronic paddle-free flow switch. Auto-setting according to cooler size and fluid type.
- Auto-adaptive control
 - Control algorithm prevents excessive compressor cycling
 - Automatic compressor unloading in case of abnormally high condensing pressure or discharge temperature.
- Exceptional endurance tests
 - Partnerships with specialised laboratories and use of limit simulation tools (finite element calculation) for the design of critical components.
 - Transport simulation test in the laboratory on a vibrating table and then on an endurance circuit (based on a military standard).

Easy and fast installation

- Compact design
 - The 30XW-V/30XWHV units are designed to offer compact dimensions for easy installation.
 - With a width of approximately 1.25 m up to 1000 kW the units can pass through standard door openings and only require minimum floor space in the plant room.
- Simplified electrical connections
 - Main disconnect switch with high trip capacity
 - Transformer supply to the integrated control circuit (400/24 V)
- Simplified water connections
 - Victaulic connections on the evaporator and condenser
 - Practical reference marks for entering and leaving water connections
 - Possibility to reverse the heat exchanger water inlet and outlet at the factory
 - Possibility to modify the number of heat exchanger passes
- Fast commissioning
 - Systematic factory operation test before shipment
 - Quick-test function for step-by-step verification of the instruments, expansion devices and compressors.

Minimised operating sound levels

- The inverter technology used for the compressor motors minimises noise levels at part load operation. In two-compressor units at 25% of the maximum load the unit sound power level is reduced by 10 dB(A).
- Standard unit features include:
 - Silencers on the compressor discharge line.
 - Sound insulation on the components that are most subjected to radiated noise.
- Option 257 further reduces the global unit sound level.

Environmental care

- R-134a refrigerant
 - HFC-refrigerant with zero ozone depletion potential
- Leak-tight refrigerant circuit
 - Reduction of leaks as no capillary tubes and flare connections are used
 - Verification of pressure transducers and temperature sensors without transferring refrigerant charge
 - Discharge line shut-off valve and liquid line service valve for simplified maintenance.

Designed to support green building design

- A green building is a building that is environmentally sustainable and has been designed, constructed and is operated to minimise the total impact on the environment. The underlying principles of this approach: The resulting building will be economical to operate, offer increased comfort and create a healthier environment for the people who live and work there, increasing productivity.

CUSTOMER BENEFITS

- The air conditioning system can use between 30 and 40% of the annual building energy consumption. Selection of the right air conditioning system is one of the main aspects to consider when designing a green building. For buildings with a variable load throughout the year, 30XW-V/30XWHV units offers a solution to this important challenge.
- A number of green building certification programs exist in the market and offer third-party assessment of green building measures for a wide variety of building types.
- The following example looks at how Carrier's new 30XW-V/30XWHV range helps customers involved in LEED® building certification.

30XW-V/30XWHV and LEED® certification

The LEED® (Leadership in Energy and Environmental Design) green building certification programme is a pre-eminent programme to rate the design, construction and operation of green buildings with points assigned in seven credit categories:

- Sustainable Sites (SS)
- Water Efficiency (WE)
- Energy & Atmosphere (EA)
- Materials & Resources (MR)
- Indoor Environmental Quality (IEQ)
- Innovation in Design (ID)
- Regional Priority (RP)

There are a number of different LEED® products.

While the strategies and categories assessed remain same, the point distribution varies to address different building types and application needs, for example according to New Construction, Schools, Core & Shell, Retail and Healthcare. All programmes now use the same point scale:

110 Possible LEED® points

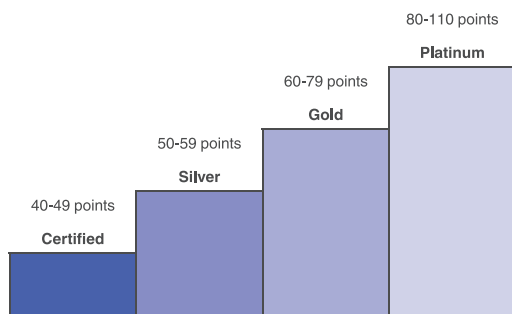

The majority of credits in LEED® rating systems are performance-based and achieving them is dependent on the impacts of each component or sub-system to the overall building.

While the LEED® green building certification programs do not certify products or services, the selection of the right products, systems or service programs is critical to obtain LEED® certification for a registered project, because the right products or service programmes can help meet the goals of green construction and ongoing operation and maintenance.

The choice of heating, ventilating and air conditioning (HVAC) products in particular can have a significant impact on LEED® certification, as the HVAC system directly impacts two categories that together influence 40% of the available points.

Overview of LEED® for new construction and major renovations

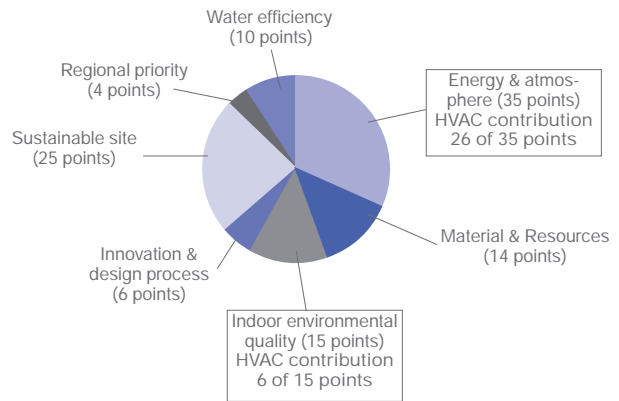

The new 30XW-V/30XWHV units from Carrier can assist building owners to earn LEED® points in particular in the Energy & Atmosphere (EA) credit category and help address the following prerequisites and credit requirements:

- **EA prerequisite 2: Minimum energy Performance**
The 30XW-V/30XWHV exceeds the energy efficiency requirements of ASHRAE 90,1-2007; therefore it complies with the prerequisite standard.
- **EA prerequisite 3: Fundamental Refrigerant Management**
The 30XW-V/30XWHV does not use chlorofluorocarbon (CFC) refrigerants thus satisfying the prerequisite statement.
- **EA credit 1: Optimise energy performance (1 to 19 points)**
Points for this credit are assigned depending on the energy cost reduction virtually achievable by the new building, compared to ASHRAE 90,1-2007 reference. The 30XW-V/30XWHV, which is designed for high performance especially during part load operation, contributes reducing the energy consumption of the building and therefore helps gaining points within this credit. In addition, the Carrier HAP (Hourly Analyses Program) can be used as an energy analyses program complying with the modeling requirements for this credit and produce reports that are easily transferable to LEED® templates.
- **EA credit 4: Enhanced refrigerant management (2 points)**
With this credit, LEED® awards systems that minimise the Ozone Depletion Potential (ODP) and Global Warming Potential (GWP) of the system. The 30XW-V/30XWHV uses a reduced R134a charge and therefore contributes toward satisfying this credit under LEED®.

NOTE: This section describes the prerequisites and credit requirements in LEED® for New Construction and is directly related to the 30XW-V/30XWHV. Other prerequisites and credit requirements are not directly and purely related to the air-conditioning unit itself, but more to the control of the complete HVAC system.

i-Vu®, Carrier's open control system, has features that can be valuable for:

- EA prerequisite 1: Fundamental commissioning of energy management system
- EA credit 3: Enhanced commissioning (2 points)
- EA credit 5: Measurements and verification (3 points).

NOTE: Products are not reviewed or certified under LEED®. LEED® credit requirements cover the performance of materials in aggregate, not the performance of individual products or brands. For more information on LEED®, visit www.usgbc.org.

TECHNICAL INSIGHTS

Touch Pilot control



- New innovative smart control features:
 - An intuitive and user-friendly, coloured, 7" interface
 - Direct access to the unit's technical drawings and the main service documents
 - Screen-shots with concise and clear information in local languages
 - Complete menu, customised for different users (end user, service personnel and Carrier-factory technicians)
 - Safe operation and unit setting: password protection ensures that unauthorised people cannot modify any advanced parameters
 - Simple and "smart" intelligence uses data collection from the constant monitoring of all machine parameters to optimise unit operation.
- Energy management
 - Internal time schedule clock: controls chiller on/off times and operation at a second set-point
 - Set-point reset based on the return water temperature
 - The DCT (Data Collection Tool) records the alarms history to simplify and facilitate service operations.

Remote management (standard)

- Units with Touch Pilot control can be easily accessed from the internet, using a PC with an Ethernet connection. This makes remote control quick and easy and offers significant advantages for service operations.
- Aquaforce with Greenspeed® Intelligence is equipped with an RS485 serial port that offers multiple remote control, monitoring and diagnostic possibilities. When networked with other Carrier equipment through the CCN (Carrier Comfort Network - proprietary protocol), all components form a HVAC system fully-integrated and balanced through one of the Carrier's network system products, like the Chiller System Manager or the Plant System Manager (optional).
- The 30XW-V/30XWHV also communicates with other building management systems via optional communication gateways.
- The following commands/visualisations are possible from remote connection:
 - Condenser pumps control: a digital input allows verification of condenser water flow (the flow switch must be supplied by the installer)
 - Start/Stop of the machine
 - Dual set-point management: Through a dedicated contact is possible to activate a second set-point (example, unoccupied mode)
 - Demand limit setting: To limit the maximum chiller capacity to a predefined value
 - Water pump control: These outputs control the contactors of one/two evaporator water pumps.
 - Operation visualisation: Indication if the unit is operating or if it is in stand-by (no cooling load)
 - Alarm visualisation.

TECHNICAL INSIGHTS

Remote management (EMM option)

The Energy Management Module offers extended remote control possibilities:

- Room temperature: permits set-point reset based on the building indoor air temperature (with Carrier thermostat)
- Set-point reset: ensures reset of the cooling set-point based on a 4-20 mA or 0-10 V signal
- Demand limit: permits limitation of the maximum chiller power or current based on a 0-10 V signal
- Demand limit 1 and 2: closing of these contacts limits the maximum chiller power or current to two predefined values
- User safety: this contact can be used for any customer safety loop; opening the contact generates a specific alarm
- Ice storage end: when ice storage has finished, this input permits return to the second set-point (unoccupied mode)
- Time schedule override: closing of this contact cancels the time schedule effects
- Out of service: this signal indicates that the chiller is completely out of service
- Chiller capacity: this analogue output (0-10 V) gives an immediate indication of the chiller capacity
- Alert indication: this volt-free contact indicates the necessity to carry out a maintenance operation or the presence of a minor fault.
- Compressors running status : set of outputs (as many as the compressors number) indicating which compressors are running.

New inverter-driven Thunderbolt screw compressor

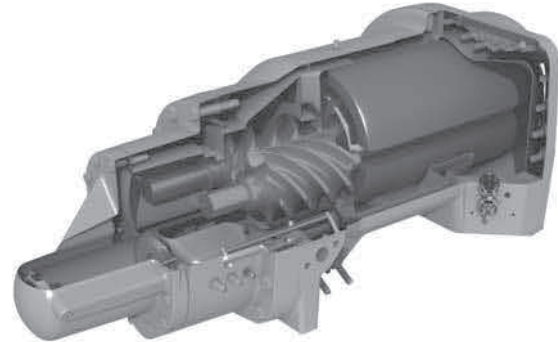

- The new generation of Carrier inverter-driven screw compressors benefits from Carrier's long experience in the development of twin-rotor screw compressors. The design of the Thunderbolt compressors is based on the successful 06T screw compressor, core of the well-known Aquaforce series.
- Advanced control algorithms combine inverter frequency output with motor input logic to minimise mechanical part stress, resulting in best compression performance and high chiller reliability. The compressor is equipped with bearings with oversized rollers, oil pressure lubricated for reliable and durable operation, even at maximum load.
- Screw compressors use positive displacement principle to compress gases at higher pressure. As a result, in case of exceptional high temperature condenser side (due for example to water-pipes fouling or operation in harsh climate with an external dry-cooler) the compressor does not switch off, but continues operation at reduced capacity (unloaded mode).
- The silencer in the discharge line considerably reduces discharge gas pulsations for much quieter operation.
- The condenser includes an oil separator that minimises the amount of oil in circulation in the refrigerant circuit and re-directs it to the compressor function.

OPTIONS

Options	No.	Description	Advantages	Use
Light-brine solution, down to -3°C	8	Implementation of new algorithms of control to allow chilled brine solution production down to -3°C when ethylene glycol is used (0°C with propylene glycol)	Matches with most application requirements for ground-sourced heat pumps and fits with many industrial processes requirements	580-1710 (see dedicated paragraph)
Master/slave operation	58	Unit equipped with supplementary water outlet temperature sensor kit to be field-installed allowing master/slave operation of two units connected in parallel	Optimised operation of two chillers connected in parallel with operating time equalisation	580-1710
Single power connection point	81	Unit power connection via one main supply connection	Quick and easy installation	1150-1710
Evap. pump power/control circuit	84	Unit equipped with an electrical power and control circuit for one pump evaporator side	Quick and easy installation: the control of fixed speed pumps is embedded in the unit control	580-1710
Evaporator dual pumps electrical power / control circuit	84D	Unit equipped with an electrical power and control circuit for two pumps evaporator side	Quick and easy installation: the control of fixed speed pumps is embedded in the unit control	580-1710
Cond. pump power/control circuit	84R	Unit equipped with an electrical power and control circuit for one pump condenser side	Quick and easy installation: the control of fixed speed pumps is embedded in the unit control	580-1710
Cond. dual pumps power/control circuit	84T	Unit equipped with an electrical power and control circuit for two pumps condenser side	Quick and easy installation: the control of fixed speed pumps is embedded in the unit control	580-1710
Condenser insulation	86	Thermal condenser insulation	Minimizes thermal dispersions condenser side (key option for heat pump or heat recovery applications) and allows compliancy with special installation criteria (hot parts insulated)	580-1710
Service valve set	92	Liquid line valve (evaporator inlet) and compressor suction line valve	Allow isolation of various refrigerant circuit components for simplified service and maintenance	580-1710
Evaporator with one pass less	100C	Evaporator with one pass on the water side. Evaporator inlet and outlet on opposite sides.	Easy to install, depending on site. Reduced pressure drops	580-1710
Condenser with one pass less	102C	Condenser with one pass on the water side. Condenser inlet and outlet on opposite sides.	Easy to install, depending on site. Reduced pressure drops	580-1710
21 bar evaporator	104	Reinforced evaporator for extension of the maximum water-side service pressure to 21 bar (standard 10 bar)	Covers applications with a high water column evaporator side (typically high buildings)	580-1710
21 bar condenser	104A	Reinforced condenser for extension of the maximum water-side service pressure to 21 bar (standard 10 bar)	Covers applications with a high water column condenser side (typically high buildings)	580-1710
Reversed evaporator water connections	107	Evaporator with reversed water inlet/outlet	Easy installation on sites with specific requirements	580-1710
Reversed condenser water connections	107A	Condenser with reversed water inlet/outlet	Easy installation on sites with specific requirements	580-1710
JBus gateway	148B	Two-directional communication board complying with JBus protocol	Connects the unit by communication bus to a building management system	580-1710
LON gateway	148D	Two-directional communication board complying with LON protocol	Connects the unit by communication bus to a building management system	580-1710
Bacnet over IP gateway	149	Two-directional high-speed communication using BACnet protocol over Ethernet network (IP)	Easy and high-speed connection by ethernet line to a building management system. Allows access to multiple unit parameters	580-1710
Condensing temperature limitation	150B	Limitation of the maximum condenser leaving water temperature to 45°C	Reduced maximum power input and current absorption: power cables and protection elements can therefore be downsized	580-1710
Control for low condensing temperature systems	152	Output signal (0-10 V) to control the condenser water inlet valve	Simple installation: for applications with cold water at condenser inlet (ex. ground-source, groundwater-source, superficial water-source applications) the signal permits to control a 2 or 3-way valve to maintain condenser water temperature (and so condensing pressure) at acceptable values	580-1710
Energy Management Module EMM	156	Control board with additional inputs/outputs. See Energy Management Module option chapter	Extended remote control capabilities (Set-point reset, ice storage end, demand limits, boiler on/off command...)	580-1710

OPTIONS

Options	No.	Description	Advantages	Use
Leak detection	159	0-10 V signal to report any refrigerant leakage in the unit directly on the controller (the leak detector itself must be supplied by the customer)	Immediate customer notification of refrigerant losses to the atmosphere, allowing timely corrective actions	580-1710
Compliance with Swiss regulations	197	Additional tests on the water heat exchangers: supply (additional of PED documents) supplementary certificates and test certifications	Conformance with Swiss regulations	580-1710
Low noise level	257	Evaporator sound insulation	3 dB(A) quieter than standard unit	580-1710
Welded evaporator water connection kit	266	Victaulic piping connections with welded joints	Easy installation	580-1710
Welded condenser water connection kit	267	Victaulic piping connections with welded joints	Easy installation	580-1710
Flanged evaporator water connection kit	268	Victaulic piping connections with flanged joints	Easy installation	580-1710
Flanged condenser water connection kit	269	Victaulic piping connections with flanged joints	Easy installation	580-1710
Thermal compressor insulation	271	The compressor is covered with a thermal insulation layer	Prevents air humidity to condensate on the compressor surface	580-1710
EMC classification C2, as per EN 61800-3	282	Additional RFI filters on the unit power line	Reduces electromagnetic interferences. Increase the variable frequency drive (VFD) immunity level according to first environment (so called, residential environment) requirements and allow its compliancy with emissions level required in category C2	580-1710
Fast Capacity Recovery	QM295	New software algorithms to allow quick restart and fast loading while preserving unit-reliability	Full capacity recovery in less than 5 minutes after power failure. Matches requirements of typical critical missions applications	580-1710
Carrier Connect link (BSS regions only)	298	3G router board NOTE 1: Require option 149 NOTE 2: When more than one machine is installed on site, only one of them shall be equipped with option 298 while all of them must be equipped with option 149 NOTE 3: If a CARRIER-PSM is on site, option 298 shall be integrated in the PSM while option 149 is still mandatory for each single unit.	Enabler for Carrier Connect service offer	580-1710

PHYSICAL DATA, 30XW-V UNITS

30XW-V / 30XWHV			580	630	810	880	1150	1280	1470	1570	1710	
Heating												
Standard unit Full load performances *	HW1	Nominal capacity	kW	649	719	890	974	1261	1428	1594	1761	1932
		COP	kW/kW	4,64	4,53	4,56	4,43	4,62	4,61	4,55	4,33	4,16
	HW2	Nominal capacity	kW	687	767	956	1021	1335	1524	1712	1898	2067
		COP	kW/kW	6,15	5,98	5,96	5,81	6,05	6,00	5,82	5,49	5,34
Seasonal energy efficiency **	HW2	SCOP _{30/35°C}	kWh/kWh	7,32	7,05	7,21	6,96	6,95	6,66	6,37	6,13	5,87
		Ijs heat _{30/35°C}	%	285	274	280	270	270	259	247	237	227
		P _{rated}	kW	818	913	1134	1216	1589	1815	2041	2263	2463
Cooling												
Standard unit Full load performances*	CW1	Nominal capacity	kW	587	652	812	858	1140	1305	1461	1604	1741
		EER	kW/kW	5,44	5,31	5,25	5,07	5,45	5,50	5,38	5,05	4,94
		Eurovent class		A	A	A	A	A	A	A	A	B
	CW2	Nominal capacity	kW	791	846	1023	970	1528	1688	1703	2093	2272
		EER	kW/kW	6,96	6,50	6,22	5,63	6,86	6,64	5,99	5,99	5,99
Seasonal energy efficiency		SEER _{12/17°C} Comfort low temp.	kWh/kWh	8,00	7,66	8,43	7,93	8,31	8,19	7,74	7,70	7,34
		Ijs cool _{12/17°C}	%	317	303	334	314	329	325	307	305	290
		SEPR _{12/17°C} Process high temp.	kWh/kWh	8,07	8,02	7,73	6,76	8,04	8,07	7,96	7,89	7,49
		SEER _{23/18°C} Comfort medium temp.	kWh/kWh	383	358	365	352	398	383	313	366	348
Integrated Part Load Value	IPLV.SI	kW/kW	9,060	9,120	9,450	8,950	9,240	9,300	9,170	9,300	8,980	
Sound levels - standard unit												
Sound power level ⁽¹⁾		dB(A)	105	105	105	105	106	106	106	106	106	
Sound pressure level at 1 m ⁽²⁾		dB(A)	87	87	87	87	87	87	87	87	87	
Sound levels - standard unit + option 257 ⁽³⁾												
Sound power level ⁽¹⁾		dB(A)	102	102	102	102	103	103	103	103	103	
Sound pressure level at 1 m ⁽²⁾		dB(A)	84	84	84	84	84	84	84	84	84	
Dimensions - standard unit												
Length		mm	3059	3059	3290	3290	4730	4730	4730	4730	4730	
Width		mm	1087	1087	1237	1237	1164	1164	1255	1255	1255	
Height		mm	1743	1743	1950	1950	1997	1997	2051	2051	2051	
Operating weight ⁽⁴⁾		kg	3152	3190	4157	4161	7322	7398	7574	7770	7808	
Compressors												
Semi-hermetic 06T screw compressors, 60 r/s												
Circuit A		-	1	1	1	1	1	1	1	1	1	
Circuit B		-	-	-	-	-	1	1	1	1	1	
Oil - standard unit												
SW220 or RL220H												
Circuit A		l	32	32	36	36	32	32	36	36	36	
Circuit B		l	-	-	-	-	32	32	32	36	36	

* In accordance with standard EN14511-3:2013.
 ** In accordance with standard EN14825:2013, average climate
 HW1 Heating mode conditions: Evaporator entering/leaving water temperature 10°C/7°C, condenser entering/leaving water temperature 40°C/45°C, evaporator and condenser fouling factor 0 m2. k/W
 HW2 Heating mode conditions: Evaporator entering/leaving water temperature 10°C/7°C, condenser entering/leaving water temperature 30°C/35°C, evaporator and condenser fouling factor 0 m2. k/W
 CW1 Cooling mode conditions: Evaporator water entering/leaving temperature 12°C/7°C, condenser entering/leaving water temperature 30°C/35°C, evaporator and condenser fouling factor 0 m2.K/W
 CW2 Cooling mode conditions: Evaporator water entering/leaving temperature 23°C/18°C, condenser entering/leaving water temperature 30°C/35°C, evaporator and condenser fouling factor 0 m2.K/W
 (1) In dB ref=10⁻¹² W, (A) weighting. Declared dualnumber noise emission values in accordance with ISO 4871 (with an associated uncertainty of +/-3dB(A)). Measured in accordance with ISO 9614-1 and certified by Eurovent.3dB(A)). Measured in accordance with ISO 9614-1 and certified by Eurovent.
 (2) in dB ref 20µPa, (A) weighting. Declared dualnumber noise emission values in accordance with ISO 4871 (with an associated uncertainty of +/-3dB(A)). For information, calculated from the sound power level Lw(A).
 (3) Option 257 = Low noise level
 (4) Weight shown is guideline only. To find out the unit refrigerant charge, please refer to the unit nameplate

Ijs heat_{30/35°C} & SCOP_{30/35°C} Applicable Ecodesign regulation: (EU) No 813/2013
 Ijs cool_{12/17°C} & SEER_{12/17°C} Applicable Ecodesign regulation: (EU) No 2016/2281
 SEPR_{12/17°C} Applicable Ecodesign regulation: (EU) No 2016/2281
 SEER_{23/18°C} Applicable Ecodesign regulation (EU) No 2016/2281
 IPLV.SI Calculations according to standard performances AHRI 551-591.



Eurovent certified values



AHRI certified values 30XW-only

PHYSICAL DATA, 30XW-V UNITS

30XW-V / 30XWHV		580	630	810	880	1150	1280	1470	1570	1710
Refrigerant - standard unit		R-134a								
Circuit A	kg	130	130	180	175	120	120	115	115	110
	teqCO ₂	186	186	257	250	172	172	164	164	157
Circuit B	kg	-	-	-	-	120	120	120	115	110
	teqCO ₂	-	-	-	-	172	172	172	164	157
Capacity control		Touch Pilot, inverter-driven compressor, electronic expansion valve (EXV)								
Minimum capacity	%	20	20	20	20	10	10	10	10	10
Evaporator		Multi-pipe flooded type								
Water volume	l	106	106	154	154	297	297	297	297	297
Water connections (Victaulic)	in	6	6	8	8	8	8	8	8	8
Drain and vent connections (NPT)	in	3/8	3/8	3/8	3/8	3/8	3/8	3/8	3/8	3/8
Max. water-side operating pressure	kPa	1000	1000	1000	1000	1000	1000	1000	1000	1000
Condenser		Multi-pipe flooded type								
Water volume	l	112	112	165	165	340	340	340	340	340
Water connections (Victaulic)	in	6	6	8	8	8	8	8	8	8
Drain and vent connections (NPT)	in	3/8	3/8	3/8	3/8	3/8	3/8	3/8	3/8	3/8
Max. water-side operating pressure	kPa	1000	1000	1000	1000	1000	1000	1000	1000	1000

ELECTRICAL DATA

30XW-V/30XWHV		580	630	810	880	1150	1280	1470	1570	1710
Power circuit										
Nominal power supply	V-ph-Hz	400-3-50								
Voltage range	V	360-440								
Control circuit										
24 V via the built-in transformer										
Start-up current*										
A Lower than the operating current										
Maximum power factor**										
		0.91-0.93	0.91-0.93	0.91-0.93	0.91-0.93	0.91-0.93	0.91-0.93	0.91-0.93	0.91-0.93	0.91-0.93
Cosine phi										
		>0.98	>0.98	>0.98	>0.98	>0.98	>0.98	>0.98	>0.98	>0.98
Total harmonic distortion†	%	35-45	35-45	35-45	35-45	35-45	35-45	35-45	35-45	35-45
Maximum power input***										
Circuit A	kW	155	193	222	246	155	193	222	222	246
Circuit B	kW	-	-	-	-	155	193	193	222	246
With option 81	kW	-	-	-	-	310	386	415	444	492
Eurovent current draw****										
Circuit A	A	175	200	240	265	175	200	240	240	265
Circuit B	A	-	-	-	-	175	200	200	240	265
With option 81	A	-	-	-	-	350	400	440	480	530
Maximum current draw (Un)***										
Circuit A	A	245	300	346	383	245	300	346	346	383
Circuit B	A	-	-	-	-	245	300	300	346	383
With option 81	A	-	-	-	-	490	600	646	692	766
Maximum current draw (Un -10%)***										
Circuit A	A	270	330	380	421	270	330	380	380	421
Circuit B	A	-	-	-	-	270	330	330	380	421
With option 81	A	-	-	-	-	540	660	710	760	842
Maximum power input with option 150B***										
Circuit A	kW	141	173	199	221	141	173	199	199	221
Circuit B	kW	-	-	-	-	141	173	173	199	221
With option 81	kW	-	-	-	-	282	346	372	398	442
Maximum current draw (Un) with option 150B***										
Circuit A	A	222	272	314	348	222	272	314	314	348
Circuit B	A	-	-	-	-	222	272	272	314	348
With option 81	A	-	-	-	-	444	544	586	628	696
Dissipated power†										
	W	3000	4200	4700	5300	6000	8400	8900	9400	10600

* Instantaneous start-up current

** This can vary as a function of the short-circuit current/maximum current ratio of the system transformer. Values obtained at operation with maximum unit power input.

*** Values obtained at operation with maximum unit power input. Values given on the unit name plate.

**** Eurovent unit operating conditions: evaporator entering/leaving water temperature = 12°C/7°C, condenser entering/leaving water temperature = 30°C/35°C. Gross performances, not in accordance with EN14511-3:2013. These performances do not take into account the correction for the proportional heating capacity and power input generated by the water pump to overcome the internal pressure drop in the heat exchanger.

† Values obtained at operation with maximum unit power input.

DIMENSIONS/CLEARANCES

30XW-V/30XWHV 580-880

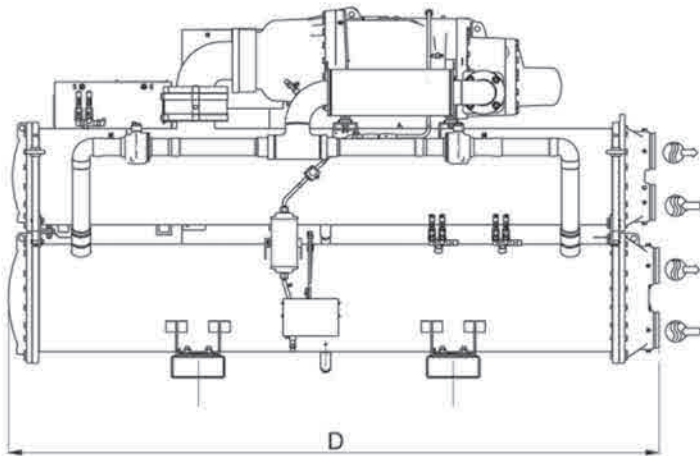
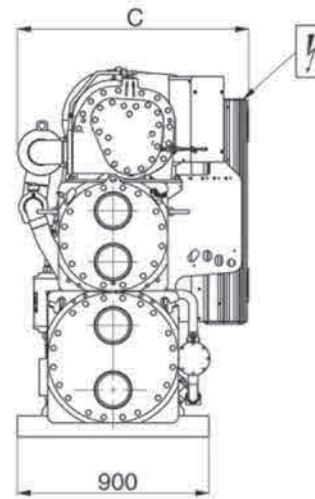
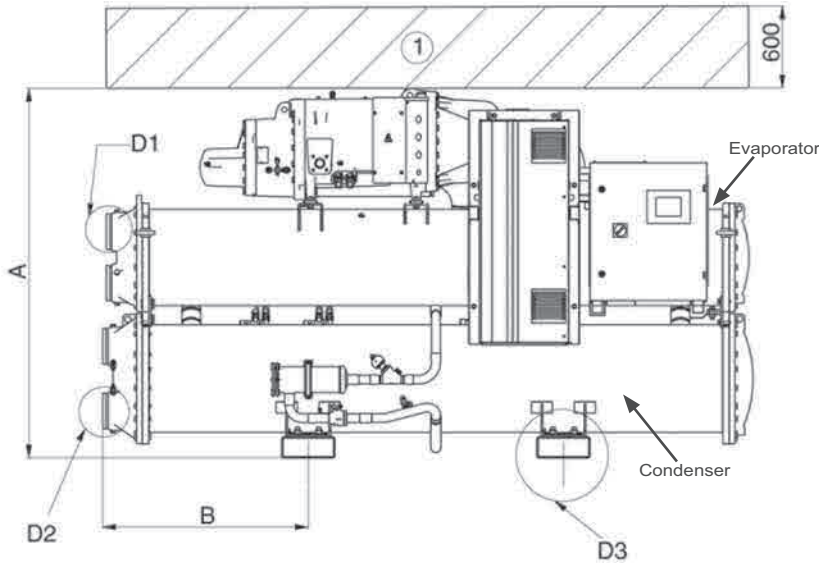

Dimensions in mm							
	A	B	C	D	E	F	G
30XW-V/30XWHV							
580	1743	968	1087	3059	168.3	168.3	2900
630	1743	968	1087	3059	168.3	168.3	2900
810	1950	1083	1237	3290	219.1	219.1	3100
880	1950	1083	1237	3290	219.1	219.1	3100

Legend:

All dimensions are in mm.

- a** Required clearance for maintenance
- b** Recommended clearance for tube removal
- Water inlet
- Water outlet
- Power supply connection

NOTE: Drawings are not contractually binding. Before designing an installation, consult the certified dimensional drawings, available on request.

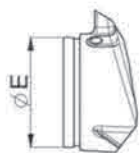
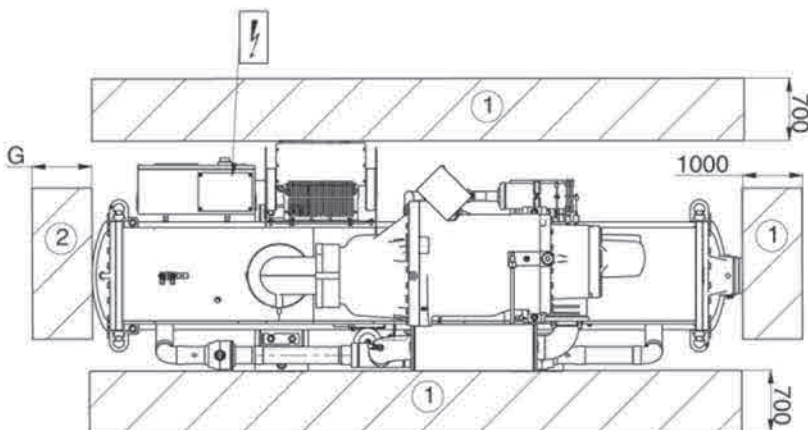

D1

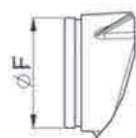

D2

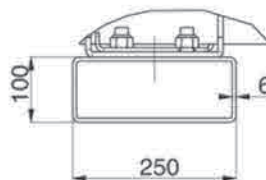

D3

DIMENSIONS/CLEARANCES

30XW-V/30XWHV 1150-1710

COOLING

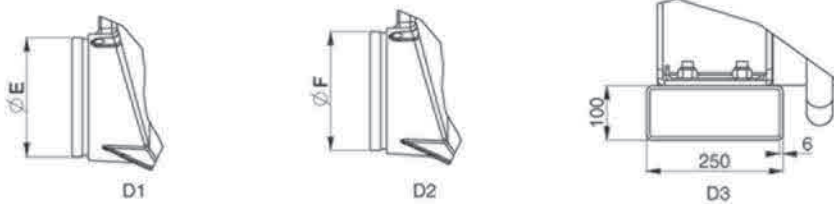
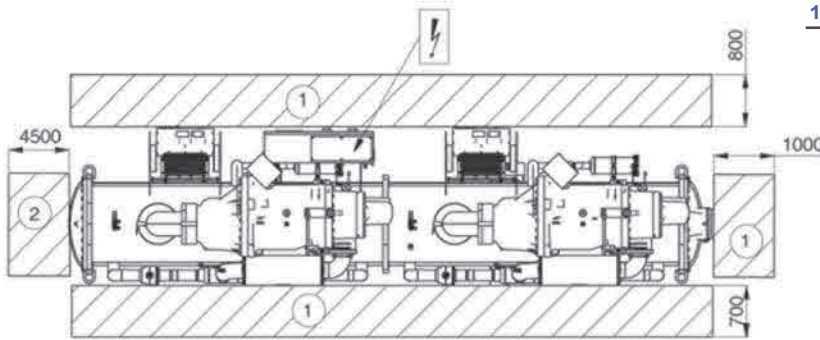
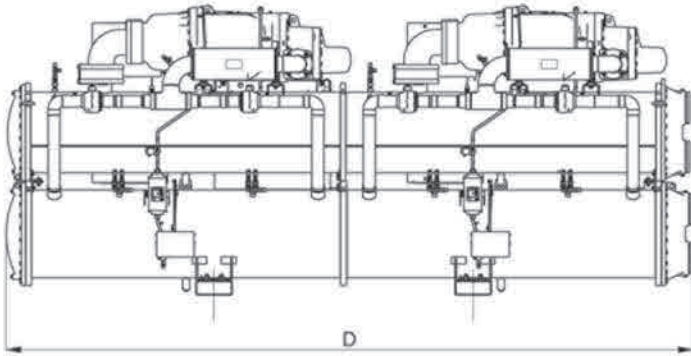
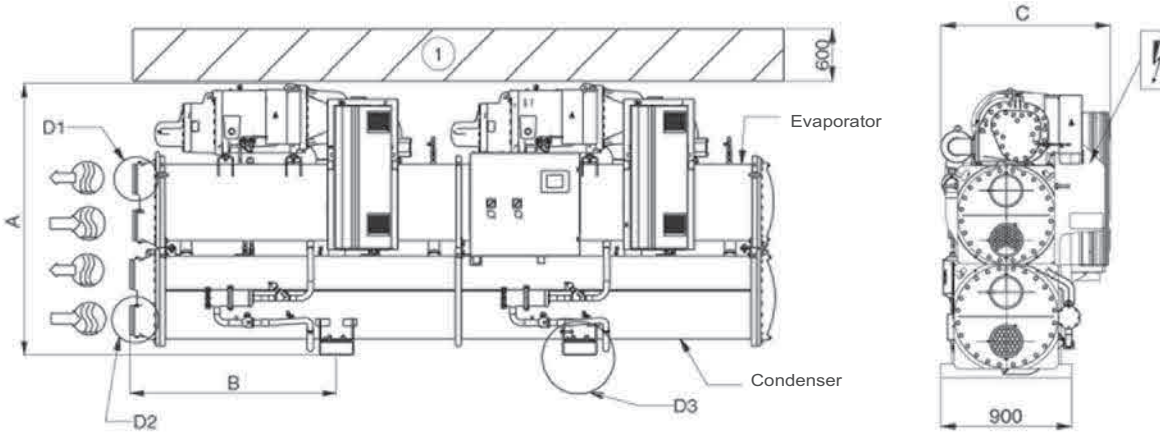

Dimensions in mm						
	A	B	C	D	E	F
30XW-V/30XWHV						
1150	1997	1514	1164	4730	219.1	219.1
1280	1997	1514	1164	4730	219.1	219.1
1470	2051	1514	1255	4730	219.1	219.1
1570	2051	1514	1255	4730	219.1	219.1
1710	2051	1514	1255	4730	219.1	219.1

Legend:

All dimensions are in mm.

- a Required clearance for maintenance
- b Recommended clearance for tube removal
- Water inlet
- Water outlet
- Power supply connection

NOTE: Drawings are not contractually binding. Before designing an installation, consult the certified dimensional drawings, available on request.