

## AIR-TO-WATER SPLIT HEAT PUMP & COMFORT MODULE

- Inverter-driven outdoor unit
- Compact comfort module
- System energy efficiency
- Easy heating solution



# 38AW/80AW



Nominal Heating capacity 5-15.0 kW  
 Nominal Cooling capacity 4.2-15.8 kW

The new reversible XP Energy air-to-water split system heat pumps with built-in inverter technology are designed for residential and light commercial applications. They offer excellent energy efficiency values, exceptionally quiet operation and meet the most stringent operating temperature demands.

The units integrate the latest technological innovations: Non-ozone depleting refrigerant R410A, DC inverter twin-rotary compressors, low-noise fan and microprocessor control. With exceptional energy efficiency values, the inverter air-to-water split-system heat pumps qualify for local tax reductions and incentive plans in all the EU countries.

The 38AW/80AW systems are specifically designed for ease-of-installation and service and underline Carrier's reputation for highest product quality and reliability.

For added flexibility, the XP Energy systems are available in heating only or reversible versions, to suit the demand.

The XP Energy heat pump systems can be used with a wide choice of Carrier terminal fan coil units - cassettes, low, medium and high-pressure satellite units, console units, under-ceiling units and high-wall units.

Ecodesign is the European Directive that sets mandatory requirements for Energy related Products (ErP) to improve their energy efficiency. Carrier supports initiatives to reduce the environmental impact of its products.



CARRIER participates in the ECP programme for LCP/HP  
 Check ongoing validity of certificate:  
[www.eurovent-certification.com](http://www.eurovent-certification.com)

## FEATURES AND BENEFITS

### Features

- Wide operating range in both heating and cooling mode offers high performance in a wide temperature range.
- DC inverter twin-rotary compressors with Pulse Amplitude Modulation (PAM) and Pulse Width Modulation (PWM) provide enhanced reliability, low energy consumption and smooth vibration-free operation under all operating conditions.
- Variable-speed fans with an innovative patented fan blade shape ensure improved air distribution at exceptionally low noise levels.
- Pre-set or customised selection of the appropriate climate curve for stable output capacity to match the heat load.
- Output to link and integrate the unit with the existing heat sources offers a dual-energy approach, increased savings and optimum comfort in all weather conditions.
- Able to control two independent comfort zones with a two-zone kit added to the main comfort module.
- Leaving water temperature up to 60 °C for radiator and domestic hot water applications, making hot water readily available.

### Adapted to your needs

- Heating only or reversible comfort module
- Backup heating, either electrical (single-energy applications) or gas boiler (dual-energy applications)
- Comfort is ensured via the user interface and the possibility of integrating two leaving water temperature zones.

### Advanced technology

- Electronic system management: Several sensors placed in key positions in the refrigerant circuit electronically detect the operational system status. Two micro-controllers receive the input from the sensors, manage them using advanced control algorithms and optimise the refrigerant flow and the functioning of all the core components - the compressor, fan motors and the pulse modulation valve.
- The pulse modulation valve, a bi-flow electronic expansion device, optimises the refrigerant amount in the circuit and the superheat, and prevents the refrigerant migration back into the compressor. This device further enhances high system performance and reliability.
- The air management system, which consists of a propeller fan, orifice and an air discharge grille, guarantees minimised noise levels.

### New patented fan blade shape and grille profile with low pressure drop

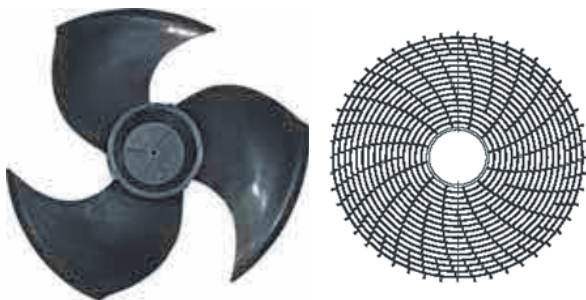

### Advanced performance

- The XP Energy heat pump systems have an extremely high energy efficiency ratio in both cooling and heating mode, ensuring significant energy savings. Large and efficient coils and optimised circuiting feature ensure that all the

combinations meet the European tax rebate efficiency targets. Efficiency at part-load conditions (seasonal energy efficiency) reaches the highest level in the industry.

- Year-round comfort: The advanced technology used in the new XP Energy heat pump condensing units provides optimised comfort levels for the end users, both in terms of water temperature control and silent operation. The desired temperature is quickly reached and effectively maintained without fluctuations. The XP Energy offers optimised individual comfort levels - both in winter and in summer.
- Wide temperature operating range: XP Energy heat pumps can operate efficiently in extreme temperature conditions. For end user comfort the units operate down to -20 °C outdoor temperature in heating mode, and in the summer, they produce hot water up to 60 °C at up to 30 °C outside temperature for domestic hot water applications.

### Environmental care

- Non-ozone depleting refrigerant R410A:
  - Chlorine-free refrigerant of the HFC group with zero ozone depletion potential
  - High-density refrigerant, therefore less refrigerant required
  - Very efficient, therefore gives an increased energy efficiency ratio (EER)
- The new packaging ensures high protection during transport and handling and is 100% recyclable.

### Fast and simple installation and service

- Easy access to all internal components: Unscrew only three screws to remove the complete front panel to access the refrigerant piping connections, control box and electrical connections, as well as the compressor and other key parts.
- Advanced circuit design and component selection has resulted in a compact unit with an exceptionally small footprint that is easy to transport through narrow doors.
- Reduced weight and a handle on the unit panels to facilitate transport.
- No additional buffer tank required. This simplifies and speeds up the installation process.
- 3-bar pressure relief valve as standard
- 8-litre internal expansion tank
- High-temperature refrigerant protection
- Water flow switch to ensure that the circuits contain enough water to operate correctly.
- Various power cable outlet options: Pre-punched holes in the cabinet panels permit cable exit on the side, front or rear.
- Dealer service tool connection kit includes the software and connections to monitor the operating parameters from a personal computer, giving an easy-to-read display with visual graphs and statistics indicators.
- All 80AW units are equipped with 1 inch gas MPT water connections.
- The 80AW comfort module reduces space requirements and simplifies the installation. Only the power and the water supply and return piping need to be connected.
- Condensate drain piping connection
- Specially shaped anchorage feet ensure correct and safe fixing of the unit.
- The programmable NUI thermostat periodically runs system checks to monitor and assess the unit operating parameters. If a problem occurs, troubleshooting fault codes and messages help the service technician to identify the fault.

## FEATURES AND BENEFITS

### DC inverter twin-rotary compressor

- Advanced technology provides maximum energy-efficiency with high capacity available at peak conditions and optimised efficiency at low and mid compressor speeds. The XP Energy heat pump DC inverter uses Intelligent Power Drive Unit (IPDU) hybrid inverter technology, combining two electronic management logics: Pulse Amplitude Modulation (PAM) and Pulse Width Modulation (PWM) for optimised compressor operation in all conditions, minimised temperature fluctuations, and provides perfect individual comfort control with significantly reduced energy consumption:
  - PAM: Pulse Amplitude Modulation of the direct current controls the compressor at maximum load conditions (start-up and peak load), and increases the voltage at fixed frequency. The compressor works at high speed to rapidly achieve the desired temperature.
  - PWM: Pulse Width Modulation of the direct current controls the compressor at partial load conditions, and adjusts the frequency at fixed voltage. The compressor speed is fine-tuned and the system provides high-level comfort (no temperature fluctuations) at exceptionally efficient working conditions.
- Compressor frequency is increased continuously up to the maximum level. This ensures that there are no current draw peaks in the start-up phase and safe connection to a single-phase power supply even in large-capacity systems. The maximum operating current of XP Energy systems is below 12 A (systems up to 6.5 kW) and below 23 A for larger systems (up to 11.5 kW). Inverter ramp-up speed makes soft starts unnecessary and ensures immediate maximum power.
- The two rotary compression cylinders, offset from each other by 180°, and the DC brushless motor with the shaft in perfect balance ensure reduced vibration and noise, even at very low operating speeds. This results in an extremely wide range between minimum and maximum capacity with continuous operation, guaranteeing that the system is always optimised and provides maximum comfort at exceptionally high efficiency levels.
- Twin-rotary cylinders, low vibrations and low load to the shaft ensure highest compressor reliability and a long trouble-free operating life.
- All DC brushless twin-rotary compressors are equipped with crankcase heaters as standard.
- A double compressor shield for acoustic insulation further reduces noise levels.

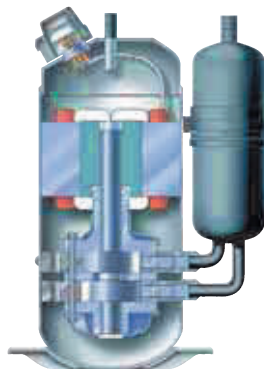

### Superior reliability

- Exceptional endurance tests:
  - Third-party testing and certification: All the performances are certified by Eurovent and unit safety is certified by IMQ.
  - All the units are tested at various stages on the production line for circuit leakage, electrical compliance, water and refrigerant pressures.
  - End-of-line test of all unit operating parameters
  - Corrosion resistance test
  - Accelerated ageing test on critical components and complete assembled units, simulating thousands of hours of continuous operation.
  - Packaging crash test to ensure that the units are adequately protected against accidental shocks
  - Extensive field and site testing.

### Corrosion-resistant casing



### Economical operation

- Increased energy efficiency at part load:
  - The exceptionally high energy efficiency of the XP Energy heat pumps is the result of a long qualification and optimisation process.
  - Use of ambient air as primary source of energy in domestic heating applications significantly reduces the overall energy consumption and minimises CO2 emissions.
  - Night mode operation at reduced compressor speed, results in low-noise operation and a significant reduction in energy consumption.
  - Easy-to-set and economical silent mode, reduces the compressor speed.
  - R-410A refrigerant is easier to use than other refrigerant blends.

### GMC board

- The new GMC controller is specifically developed for the XP Energy inverter heat pumps, and incorporates new control algorithms. It features customised or pre-defined climate curves, domestic hot water control, a night-time noise reduction function, a defrost/alarm output signal, an external heat source, a pump block prevention function, freeze protection and compressor operation management.

## FEATURES AND BENEFITS

### New user interface

- The XP Energy has an easy-to-use user interface with easy-to-read LCD screen. It provides enhanced control capability for maximised performance, reliability and indoor comfort and has extended programming features such as weekly scheduling. The sleek contemporary design blends in with any room decor.



### New comfort module

- With its enhanced aesthetics and compactness, combined with new features and options, the new XP Energy sets new standards in energy savings and comfort. Using the two-zone kit, two separate terminal units or two independent comfort zones can be closely monitored. Domestic hot water production is made easy and can be interfaced with solar thermal panels.



### Two-zone kit

- The new design facilitates the installation process and makes two independent comfort zones, which are easy to control. This kit includes a hydraulic disconnection collector, the necessary circulating pumps and modulating valve. Installed together with the domestic hot water tank, the two-zone kit can integrate all accessories, such as the diverting valve and T-connection.

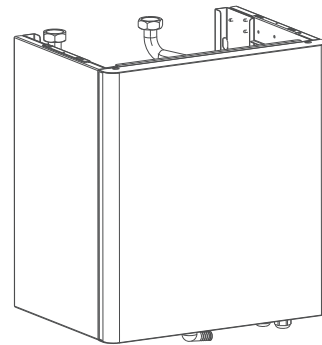

### Domestic hot water tank

- The tank is of 200 or 300 litres, with or without connection to a solar thermal panel. Built-in electric heater backup and anti-legionella protection, controlled by the comfort module, make domestic hot water readily available, safe and energy-efficient.



## TYPE KEY

### Outdoor unit

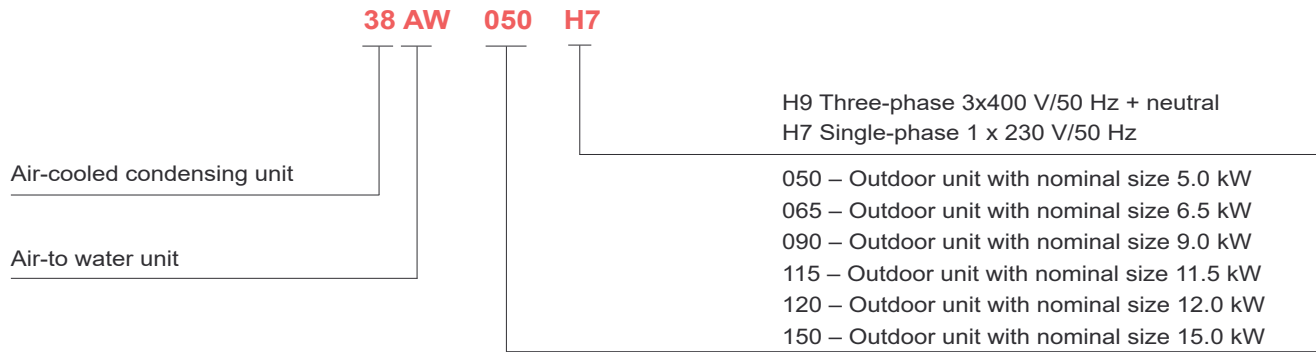

### Indoor unit

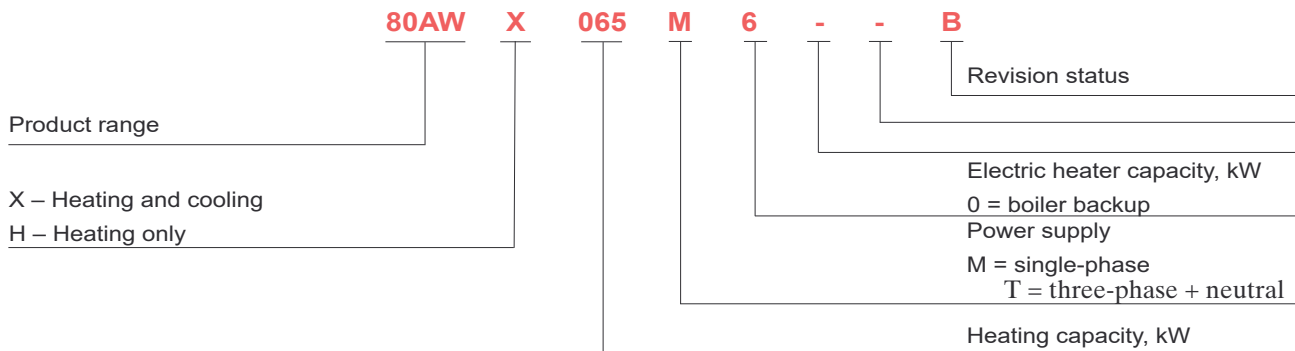

## COMBINATION TABLE, OUTDOOR AND INDOOR UNITS

Outdoor unit		Indoor unit	
38AW 050H7 38AW 065H7	5 kW nominal capacity 6.5 kW nominal capacity	80AWX 065M0	Reversible, 1 zone, max. heating capacity 6.5 kW for boiler backup
		80AWX 065M3	Reversible, 1 zone, max. heating capacity 6.5 kW with 3 kW 1-ph electric heater backup
		80AWX 065M6	Reversible, 1 zone, max. heating capacity 6.5 kW with 6 kW 1-ph electric heater backup
		80AWX 065T6	Reversible, 1 zone, max. heating capacity 6.5 kW with 6 kW 3-ph electric heater backup
		80AWH 065M0	Heating only, 1 zone, max. heating capacity 6.5 kW for boiler backup
		80AWH 065M3	Heating only, 1 zone, max. heating capacity 6.5 kW with 3 kW 1-ph electric heater backup
		80AWH 065M6	Heating only, 1 zone, max. heating capacity 6.5 kW with 6 kW 1-ph electric heater backup
		80AWH 065T6	Heating only, 1 zone, max. heating capacity 6.5 kW with 6 kW 3-ph electric heater backup
38AW 090H7 38AW 115H7	9 kW nominal capacity 11.5 kW nominal capacity	80AWX 115M0	Reversible, 1 zone, max. heating capacity 11.5 kW for boiler backup
		80AWX 115M3	Reversible, 1 zone, max. heating capacity 11.5 kW with 3 kW 1-ph electric heater backup
		80AWX 115M6	Reversible, 1 zone, max. heating capacity 11.5 kW with 6 kW 1-ph electric heater backup
		80AWX 115T6	Reversible, 1 zone, max. heating capacity 11.5 kW with 6 kW 3-ph electric heater backup
		80AWX 115T9	Reversible, 1 zone, max. heating capacity 11.5 kW with 9 kW 3-ph electric heater backup
		80AWH 115M0	Heating only, 1 zone, max. heating capacity 11.5 kW for boiler backup
		80AWH 115M3	Heating only, 1 zone, max. heating capacity 11.5 kW with 3 kW 1-ph electric heater backup
		80AWH 115M6	Heating only, 1 zone, max. heating capacity 11.5 kW with 6 kW 1-ph electric heater backup
		80AWH 115T6	Heating only, 1 zone, max. heating capacity 11.5 kW with 6 kW 3-ph electric heater backup
		80AWH 115T9	Heating only, 1 zone, max. heating capacity 11.5 kW with 9 kW 3-ph electric heater backup
38AW 120H9 38AW 150H9	12 kW nominal capacity 15 kW nominal capacity	80AWX 150M0	Reversible, 1 zone, max. heating capacity 15 kW for boiler backup
		80AWX 150T6	Reversible, 1 zone, max. heating capacity 15 kW with 6 kW 3-ph electric heater backup
		80AWX 150T9	Reversible, 1 zone, max. heating capacity 15 kW with 9 kW 3-ph electric heater backup
		80AWH 150M0	Heating only, 1 zone, max. heating capacity 15 kW for boiler backup
		80AWH 150T6	Heating only, 1 zone, max. heating capacity 15 kW with 6 kW 3-ph electric heater backup
		80AWH 150T9	Heating only, 1 zone, max. heating capacity 15 kW with 9 kW 3-ph electric heater backup

## ACCESSORIES

Part No.	Description	Advantages	Use
33AW-CS2	Additional user interface	Monitors two independent comfort zones or used together with comfort module interface	80AW 9025 & 80AWX or H
33AW-CB01	Communication kit	Necessary when adding a user interface and keeping the one on comfort module	80AWX or H
33AW-RAS02	Remote outdoor sensor	Positioned in the right place, the OAT sensor maximises comfort compared to using the condensing unit OAT sensor.	80AWX or H
33AW-RRS01	Room temperature sensor	Monitors indoor climate if user interface is left on indoor unit, or if two zones are covered and only one user interface is installed.	80AW 9025 & 80AWX or H
60STS020E03	Domestic hot water tank, 1 coil - 200 l	Storage, 200 l of domestic hot water	80AW 9025 & 80AWX or H
60STS030E03	Domestic hot water tank, 1 coil - 300 l	Storage, 300 l of domestic hot water	80AW 9025 & 80AWX or H
60STD020E03	Domestic hot water tank, 2 coils - 200 l	Storage, 200 l of domestic hot water with thermal solar panel connection	80AW 9025 & 80AWX or H
60STD030E03	Domestic hot water tank, 2 coils - 300 l	Storage, 300 l of domestic hot water with thermal solar panel connection	80AW 9025 & 80AWX or H
80AW9017	CDU rubber vibration isolators	Reduce the noise and vibration of the unit.	38AW
80AW9023	Domestic hot-water three-way valve and actuator	Necessary to connect domestic hot water tank.	80AWX or H
80AW9024	Thermal cut-out, floor heating	Necessary when connecting under-floor heating zone	80AWX or H
80AW9025	Two-zone kit	Allows independent control of two comfort zones	80AWX or H
80AW9026	Piping kit to install domestic hot-water valve and actuator (80AW9023) inside the unit	Specific DHW piping kit for the installation, used together with 80AW9025	80AW 9025 & 80AWX or H
80AW9027	Cover panel to install two-zone kit (80AW9025) detached from comfort module	Hides piping and connections, if two-zone kit is installed remotely from the main comfort module.	80AW 9025 & 80AWX or H
80AW9028	Additional 3-way valve kit	Possibility to have a 3-way valve also on the 2nd zone circuit	80AW 9025 & 80AWX or H

## PHYSICAL DATA, OUTDOOR AND INDOOR UNITS

Outdoor unit (heat pump)	38AW050H7	38AW065H7	38AW090H7	38AW115H7	38AW120H9	38AW150H9
Indoor unit (comfort module)	80AW 065	80AW 065	80AW 115	80AW 115	80AW 150	80AW 150

### 80AWX and 80AWH

#### Heating

Standard unit Full load performances*	HA1	Nominal capacity kW	5.01	6.55	9.27	11.50	12.00	15.01
		COP kW/kW	4.15	4.15	4.48	4.10	4.65	4.30
	HA2	Nominal capacity kW	4.37	5.70	8.70	11.30	11.20	14.02
		COP kW/kW	3.41	3.34	3.45	3.32	3.70	3.40
	HA3	Nominal capacity kW	4.25	5.52	7.88	10.95	11.48	11.91
		COP kW/kW	2.65	2.86	2.90	2.79	3.12	3.10
Seasonal energy efficiency** (80AWX only)	HA1	SCOP <sub>30/35°C</sub> kWh/kWh	3,10	3,00	3,20	3,19	3,82	3,67
		η <sub>s</sub> heat <sub>30/35°C</sub> %	121	117	125	125	150	144
	HA3	SCOP <sub>47/55°C</sub> kWh/kWh	<b>3.00</b>	<b>2.98</b>	<b>2.99</b>	<b>2.94</b>	<b>3.45</b>	<b>3.29</b>
		η <sub>s</sub> heat <sub>47/55°C</sub> %	<b>117</b>	<b>116</b>	<b>117</b>	<b>115</b>	<b>135</b>	<b>128</b>
		P <sub>rated</sub> kW	1.90	2.16	7.60	8.75	8.37	9.38
		Energy labelling	A+	A+	A+	A+	A++	A++
Seasonal energy efficiency** (80AWH only)	HA1	SCOP <sub>30/35°C</sub> kWh/kWh	2,94	2,85	3,16	3,15	3,76	3,62
		η <sub>s</sub> heat <sub>30/35°C</sub> %	115	111	123	123	147	142
		SCOP <sub>47/55°C</sub> kWh/kWh	2.81	2.81	2.94	2.90	3.39	3.24
		η <sub>s</sub> heat <sub>47/55°C</sub> %	110	110	115	113	133	127
	HA3	P <sub>rated</sub> kW	1.90	2.16	7.60	8.75	8.37	9.38
		Energy labelling	A+	A+	A+	A+	A++	A++

### 80AWX only

#### Cooling

Standard unit Full load performances*	CA1	Nominal capacity kW	3.57	4.73	5.95	6.80	10.30	12.60
		EER kW/kW	2.60	2.60	3.07	2.88	3.41	3.17
		Eurovent class	D	D	B	C	A	A
	CA2	Nominal capacity kW	5.10	6.55	7.88	9.00	13.50	15.79
		EER kW/kW	3.40	3.40	4.05	3.80	4.74	4.24
		Eurovent class	D	D	A	A	A	A
Seasonal energy efficiency		SEER <sub>12/7°C</sub> Comfort low temp. kWh/kWh	3,73	3,86	4,76	4,64	4,33	4,16

\* In accordance with standard EN14511-3:2013  
 \*\* In accordance with standard EN14825:2013, average climate  
 HA1 Heating mode conditions: Water heat exchanger water entering/leaving temperature 30°C/35°C, outside air temperature tdb/twb = 7°C db/6°C wb, evaporator fouling factor 0 m<sup>2</sup>.K/W  
 HA2 Heating mode conditions: Water heat exchanger water entering/leaving temperature 40°C/45°C, outside air temperature tdb/twb = 7°C db/6°C wb, evaporator fouling factor 0 m<sup>2</sup>.K/W  
 HA3 Heating mode conditions: Water heat exchanger water entering/leaving temperature 47°C/55°C, outside air temperature tdb/twb = 7°C db/6°C wb, evaporator fouling factor 0 m<sup>2</sup>.K/W  
 CA1 Cooling mode conditions: Evaporator water entering/leaving temperature 12°C/7°C, outside air temperature 35°C, evaporator fouling factor 0 m<sup>2</sup>.K/W  
 CA2 Cooling mode conditions: Evaporator water entering/leaving temperature 23°C/18°C, outside air temperature 35°C, evaporator fouling factor 0 m<sup>2</sup>.K/W  
 η<sub>s</sub> heat<sub>30/35°C</sub> & SCOP<sub>30/35°C</sub> Applicable Ecodesign regulation: (EU) No 813/2013  
 η<sub>s</sub> heat<sub>47/55°C</sub> & SCOP<sub>47/55°C</sub> Applicable Ecodesign regulation: (EU) No 813/2013  
 SEER<sub>12/7°C</sub> & SEPR<sub>12/7°C</sub> Applicable Ecodesign regulation: (EU) No 2016/2281



Eurovent certified values

## PHYSICAL DATA, OUTDOOR AND INDOOR UNITS

Outdoor unit (heat pump)		38AW050H7	38AW065H7	38AW090H7	38AW115H7	38AW120H9	38AW150H9
Indoor unit (comfort module)		80AW 065	80AW 065	80AW 115	80AW 115	80AW 150	80AW 150
<b>80AW</b>							
<b>Sound levels</b>							
Sound power level <sup>(1)</sup> (H3)	dB(A)	40.9	40.9	40.9	40.9	40.9	40.9
Sound power level <sup>(1)</sup> (C1)	dB(A)	40.9	40.9	40.9	40.9	40.9	40.9
<b>Dimension, H x L x D</b>	mm	800 x 450 x 320	800 x 450 x 320	800 x 450 x 320	800 x 450 x 320	800 x 450 x 320	800 x 450 x 320
<b>Operating weight<sup>(3)</sup></b>	kg	48	48	50	50	52	52
<b>Hydraulic module</b>							
Pump		Variable speed circulator					
Expansion tank volume	l	8	8	8	8	8	8
Available static pressure (C1)	kPa	70	68	68	65	55	41
Available static pressure (H1)	kPa	66	60	54	40	45	25
Available static pressure (H2)	kPa	68	64	57	41	50	31
Min. system water content	l	21	28	42	42	42	49
Max. water-side operating pressure	kPa	300	300	300	300	300	300
<b>Water connections with or without hydraulic module</b>							
Diameter	inch	1 M	1 M	1 M	1 M	1 M	1 M
Outside tube diameter	mm	25.4 M	25.4 M	25.4 M	25.4 M	25.4 M	25.4 M
Connections, Liquid / Gas side	inch	3/8 - 5/8	3/8 - 5/8	3/8 - 5/8	3/8 - 5/8	3/8 - 5/8	3/8 - 5/8
Chassis paint colour		White					
<b>38AW</b>							
<b>Sound levels</b>							
Sound power level <sup>(1)</sup> (H3)	dB(A)	64	65	69	70	68	68
Sound pressure level at 4m <sup>(2)</sup> (H3)	dB(A)	44	45	49	50	48	48
Sound power level <sup>(1)</sup> (C1)	dB(A)	64	65	68	70	68	68
Sound pressure level at 4 m <sup>(2)</sup> (C1)	dB(A)	44	45	48	50	48	48
<b>Dimension, H x L x D</b>	mm	690 x 900 x 320	820 x 900 x 320	1360 x 900 x 320	1360 x 900 x 320	1360 x 900 x 320	1360 x 900 x 320
<b>Operating weight<sup>(3)</sup></b>	kg	49	51	88	88	100	100
<b>Refrigerant</b>		R410A					
Circuit charge <sup>(3)</sup>	kg	1.17	1.36	2.1	2.1	3.9	3.9
	CO <sub>2</sub> eq.	2.4	2.8	4.4	4.4	8.1	8.1
<b>Compressors</b>		DC Inverter Twin-Rotary					
<b>Fans</b>		Variable speed 3 blades fan					
Quantity		1	1	2	2	2	2
Air flow	m <sup>3</sup> /h	2620	2820	5970	6360	5770	5770
Maximum connection pipe length	m	50	30	70	70	70	70
Maximum height difference	m	30	30	30	30	30	30
Precharged length	m	20	20	20	30	30	30
<b>Connections, Liquid / Gas side</b>	inch	1/4 - 1/2	3/8 - 5/8	3/8 - 5/8	3/8 - 5/8	3/8 - 5/8	3/8 - 5/8
<b>Chassis paint colour</b>		Beige					

- (1) In dB ref=10-12 W, (A) weighting. Declared dualnumber noise emission values in accordance with ISO 4871 (with an associated uncertainty of +/-3dB(A)). Measured in accordance with ISO 9614-1.  
(2) In dB ref 20μPa, (A) weighting. Declared dualnumber noise emission values in accordance with ISO 4871 (with an associated uncertainty of +/-3dB(A)). For information, calculated from the sound power level L<sub>w</sub>(A).  
(3) Weights are guideline only. Refer to the unit nameplate.



Eurovent certified values

## PHYSICAL DATA, OUTDOOR AND INDOOR UNITS

Indoor unit for 38AW 050H7 and 38AW 065H7		80AWX 065M0	80AWX 065M3	80AWX 065M6	80AWX 065T6	80AWH 065M0
Number of comfort zones		1	1	1	1	1
Electric heater element	kW	0	3	6	6	0
Heating only		No	No	No	No	Yes
Heating and cooling		Yes	Yes	Yes	Yes	No
Connection of backup boiler		Yes	No	No	No	Yes
Power supply	V-ph-Hz	230-1-50	230-1-50	230-1-50	400-3N-50	230-1-50
Indoor unit for 38AW 090H7 and 38AW 115H7		80AWX 115M0	80AWX 115M3	80AWX 115M6	80AWX 115T6	80AWX 115T9
Number of comfort zones		1	1	1	1	1
Electric heater element	kW	0	3	6	6	9
Heating only		No	No	No	No	No
Heating and cooling		Yes	Yes	Yes	Yes	Yes
Connection of backup boiler		Yes	No	No	No	No
Power supply	V-ph-Hz	230-1-50	230-1-50	230-1-50	400-3N-50	400-3N-50
Indoor unit for 38AW 120H9 and 38AW 150H9		80AWX 150M0	80AWX 150T6	80AWX 150T9	80AWH 150M0	80AWH 150T6
Number of comfort zones		1	1	1	1	1
Electric heater element	kW	0	6	9	0	6
Heating only		No	No	No	Yes	Yes
Heating and cooling		Yes	Yes	Yes	No	No
Connection of backup boiler		Yes	No	No	Yes	No
Power supply	V-ph-Hz	230-1-50	400-3N-50	400-3N-50	230-1-50	400-3N-50

Indoor unit for 38AW 050H7 and 38AW 065H7		80AWH 065M3	80AWH 065M6	80AWH 065T6		
Number of comfort zones		1	1	1		
Electric heater element	kW	3	6	6		
Heating only		Yes	Yes	Yes		
Heating and cooling		No	No	No		
Connection of backup boiler		No	No	No		
Power supply	V-ph-Hz	230-1-50	230-1-50	400-3N-50		
Indoor unit for 38AW 090H7 and 38AW 115H7		80AWH 115M0	80AWH 115M3	80AWH 115M6	80AWH 115T6	80AWH 115T9
Number of comfort zones		1	1	1	1	1
Electric heater element	kW	0	3	6	6	9
Heating only		Yes	Yes	Yes	Yes	Yes
Heating and cooling		No	No	No	No	No
Connection of backup boiler		Yes	No	No	No	No
Power supply	V-ph-Hz	230-1-50	230-1-50	230-1-50	400-3N-50	400-3N-50
Indoor unit for 38AW 120H9 and 38AW 150H9		80AWH 150T9				
Number of comfort zones		1				
Electric heater element	kW	9				
Heating only		Yes				
Heating and cooling		No				
Connection of backup boiler		No				
Power supply	V-ph-Hz	400-3N-50				

## ELECTRICAL DATA, OUTDOOR AND INDOOR UNITS

Outdoor unit		38AW 050	38AW 065	38AW 090	38AW 115	38AW 120	38AW 150
Power supply	V-ph-Hz	230-1-50	230-1-50	230-1-50	230-1-50	400-3N-50	400-3N-50
Voltage range	V-ph-Hz	198-264	198-264	198-264	198-264	376-424	376-424
Full load current	A	12	12	23	23	15.4	15.4
Fuse rating*	A	16	16	25	25	16	16
Operating current	A	5.3	6.91	9.43	12.22	6.45	8.72
Power consumption	W	1220	1590	2170	2810	2580	3490
Main power wire size	mm <sup>2</sup>	2.5	2.5	4	4	2.5	2.5
Power factor	%	0.95	0.95	0.95	0.95	0.95	0.95

\* Time delay fuse

Indoor unit (comfort module)	80AW 065				80AW 115					80AW 150			
	M0	M3	M6	T6	M0	M3	M6	T6	T9	M0	T6	T9	
<b>Outdoor units</b>	<b>38AW 050H7/38AW 065H7</b>				<b>38AW 090H7/38AW 115H7</b>					<b>38AW 120H9/38AW 150H9</b>			
Power supply	V-ph-Hz	230-1-50	230-1-50	230-1-50	400-3N-50	230-1-50	230-1-50	230-1-50	400-3N-50	400-3N-50	230-1-50	400-3N-50	400-3N-50
Voltage range	V-ph-Hz	207-253	207-253	207-253	360-440	207-253	207-253	207-253	360-440	360-440	207-253	376-424	376-424
Power input	kW	-	3	6	6	-	3	6	6	9	-	6	9
Operating current													
L1	A	-	13.0	26	8.7	-	13.0	26	8.7	13.0	-	8.7	13.0
L2	A	-	-	-	8.7	-	-	-	8.7	13.0	-	8.7	13.0
L3	A	-	-	-	8.7	-	-	-	8.7	13.0	-	8.7	13.0
N	A	-	13.0	26	-	-	13.0	26	-	-	-	-	-
Power factor	%	1	1	1	1	1	1	1	1	1	1	1	1
Indoor unit power supply and communication cable - H07 RN-F	mm <sup>2</sup>	2G x 1	2G x 1	2G x 1	2G x 1	2G x 1	2G x 1	2G x 1	2G x 1	2G x 1	2G x 1	2G x 1	2G x 1
Backup heater power supply cable - H07 RN-F	mm <sup>2</sup>	-	3G x 4	3G x 6	5G x 2.5	-	3G x 4	3G x 6	5G x 2.5	5G x 4	-	5G x 2.5	5G x 4
User interface cable (additional or remote) - FROH2R	mm <sup>2</sup>	4 x 0.75	4 x 0.75	4 x 0.75	4 x 0.75	4 x 0.75	4 x 0.75	4 x 0.75	4 x 0.75	4 x 0.75	4 x 0.75	4 x 0.75	4 x 0.75
Booster heater power supply cable - H05VV-F	mm <sup>2</sup>	3G x 2.5	3G x 2.5	3G x 2.5	3G x 2.5	3G x 2.5	3G x 2.5	3G x 2.5	3G x 2.5	3G x 2.5	3G x 2.5	3G x 2.5	3G x 2.5
DHW booster heater activation cable - FROH2R	mm <sup>2</sup>	2 x 1	2 x 1	2 x 1	2 x 1	2 x 1	2 x 1	2 x 1	2 x 1	2 x 1	2 x 1	2 x 1	2 x 1
DHW hot water sensor cable - FROH2R	mm <sup>2</sup>	2 x 0.5	2 x 0.5	2 x 0.5	2 x 0.5	2 x 0.5	2 x 0.5	2 x 0.5	2 x 0.5	2 x 0.5	2 x 0.5	2 x 0.5	2 x 0.5
Remote outdoor sensor cable - FROH2R	mm <sup>2</sup>	2 x 0.5	2 x 0.5	2 x 0.5	2 x 0.5	2 x 0.5	2 x 0.5	2 x 0.5	2 x 0.5	2 x 0.5	2 x 0.5	2 x 0.5	2 x 0.5

## SOUND LEVELS, OUTDOOR UNITS

Cooling mode										
38AW		Octave bands, Hz							Sound power levels	
		125	250	500	1000	2000	4000	8000		
050	dB	67	68	60	58	52	52	47	dB(A)	64
065	dB	66	63	63	60	55	52	51	dB(A)	65
090	dB	70	66	68	63	56	56	49	dB(A)	68
115	dB	68	69	70	64	59	58	52	dB(A)	70
120	dB	71	69	66	63	59	56	49	dB(A)	68
150	dB	72	68	66	63	60	54	50	dB(A)	68

Heating mode										
38AW		Octave bands, Hz							Sound power levels	
		125	250	500	1000	2000	4000	8000		
050	dB	68	62	61	60	54	54	46	dB(A)	64
065	dB	73	67	67	63	56	56	51	dB(A)	68
090	dB	73	66	68	63	57	56	51	dB(A)	69
115	dB	70	68	69	64	60	57	51	dB(A)	70
120	dB	72	69	66	63	59	56	50	dB(A)	68
150	dB	72	68	67	63	59	56	50	dB(A)	68

## DIMENSIONS (MM), OUTDOOR UNITS

**38AW 090-115H7**  
**38AW 120-150H9**

**38AW 065H7**

**38AW 050H7**

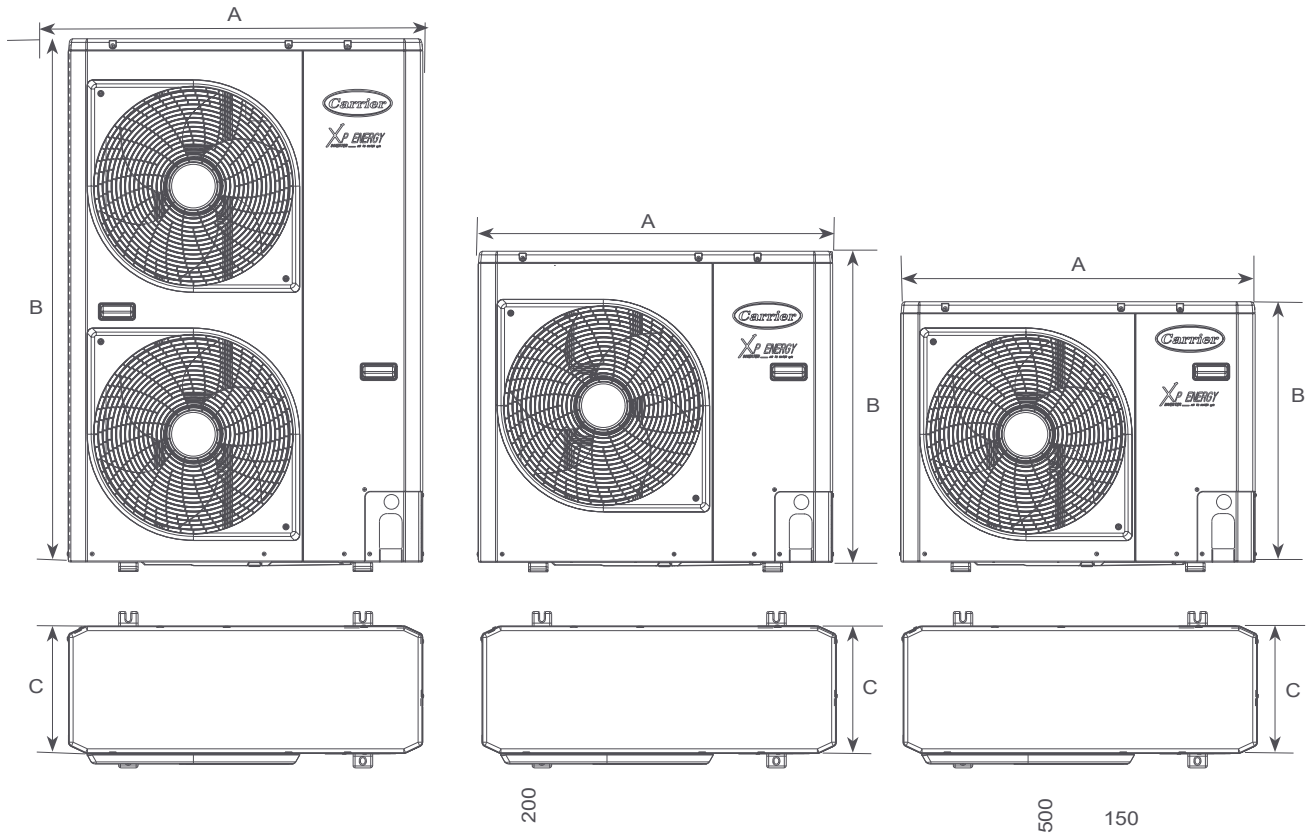

Dimensions, mm	A	B	C	Weight, kg
<b>38AW 050H7</b>	900	690	320	49
<b>38AW 065H7</b>	900	820	320	51
<b>38AW 090H7/115H7</b>	900	1360	320	88
<b>38AW 120H9/150H9</b>	900	1360	320	100

## DRAIN HOSE AND BASE PAN KNOCKOUTS

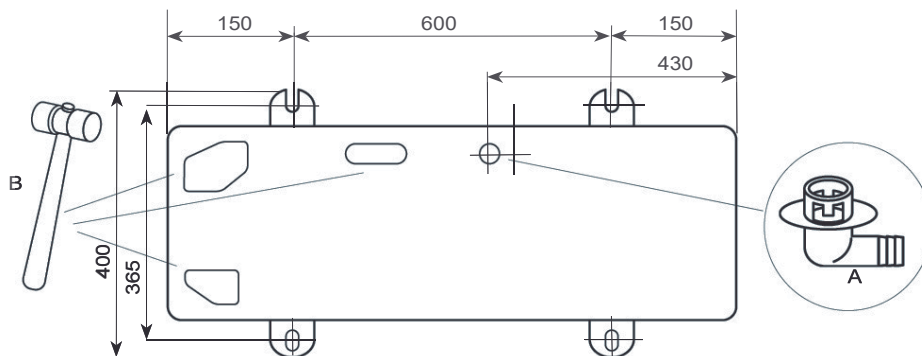

In case of draining through the drain pipe, attach the drain nipple (A) and use a drain hose with an inside diameter of 16 mm (to be provided). In cold outside temperatures when the drain pipe can freeze up, ensure that drainage is not obstructed.

Open the knockout holes in the base pan to improve the drainage capacity. Use a hammer (B) to open the knockout holes.

## CLEARANCES (MM), OUTDOOR UNITS

### Single unit installation

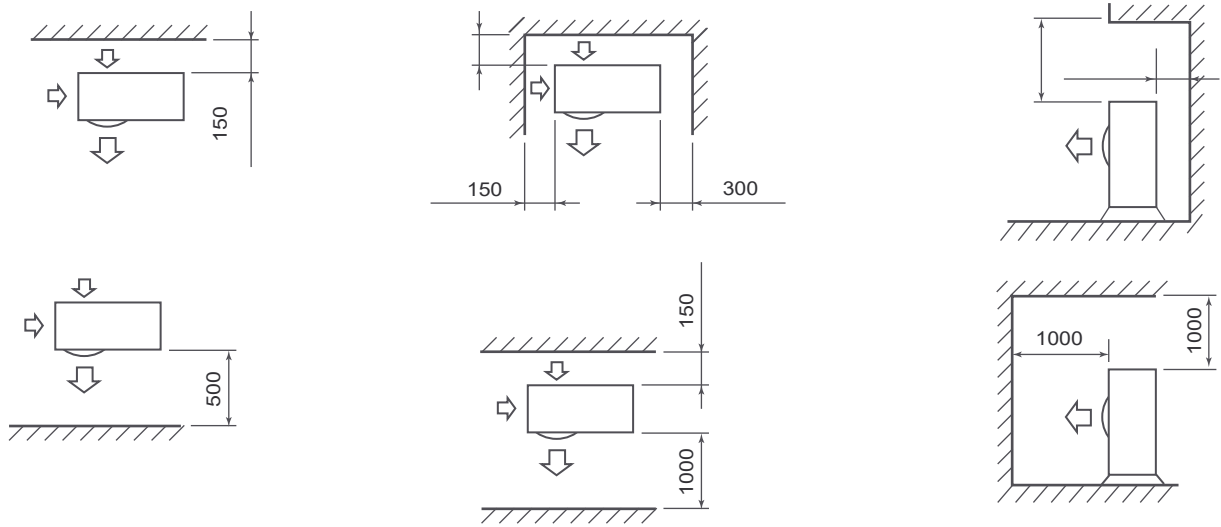

### Multiple unit installation

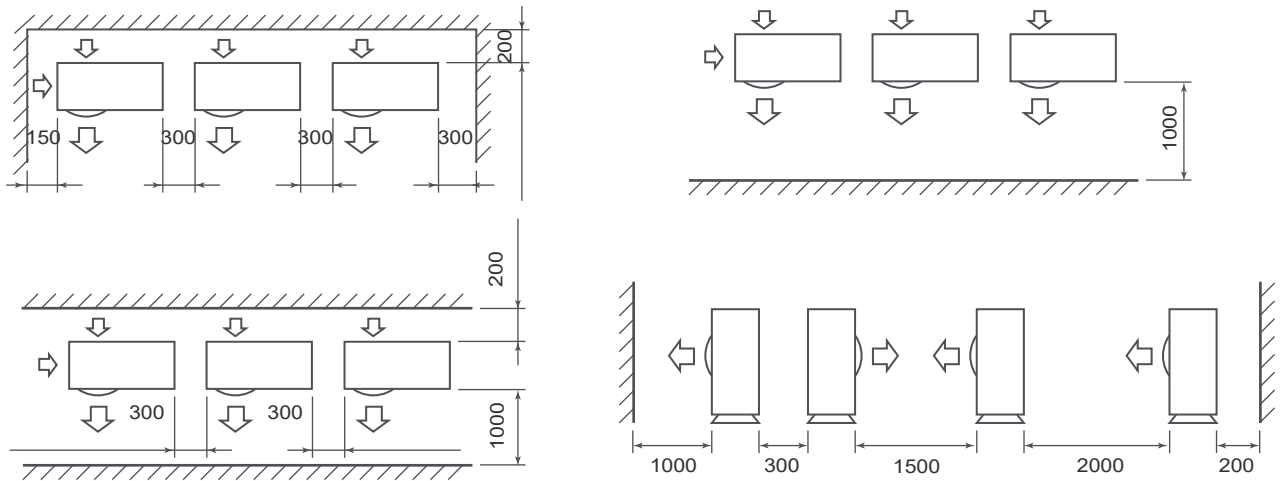

**Note:** The height of any obstacle at both the front and rear should be less than the outdoor unit height.

**DIMENSIONS, INDOOR UNITS**

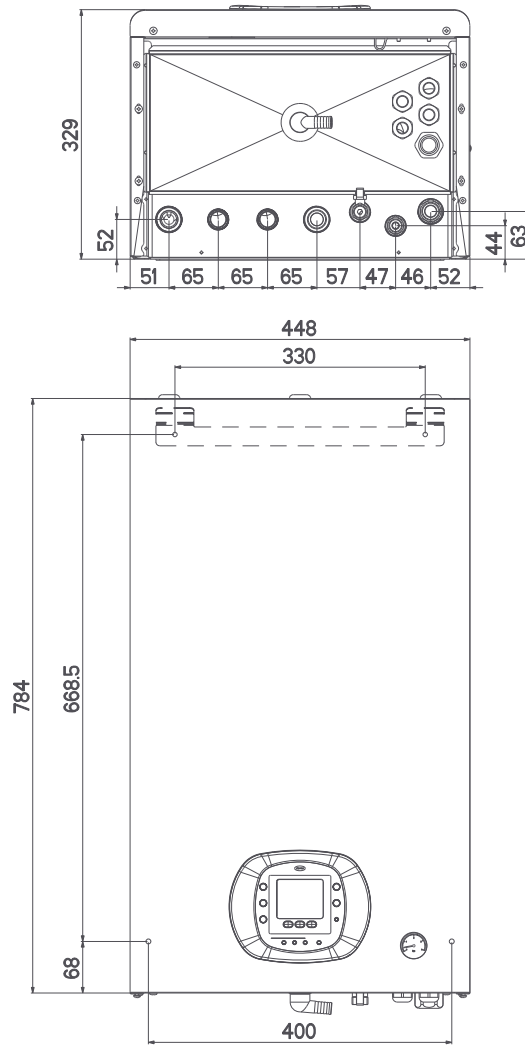

**CLEARANCES, INDOOR UNITS**

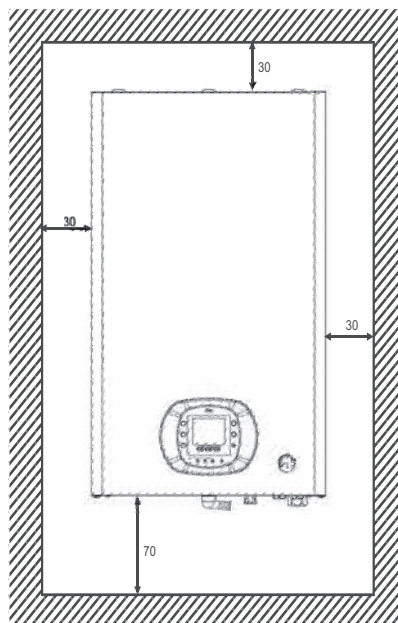

Note: All dimensions are in millimetres.

HEATING CAPACITIES IN ACCORDANCE WITH EN14511-3:2013

38AW/80AW units

LWT °C	Outside air dry-bulb (wet-bulb) temperature, °C																							
	-20 (-21)							-15 (-16)							-7 (-8)									
	Qh			COP			q	Qh			COP			q	Qh			COP			q			
	kW			kW/kW			l/s	kW			kW/kW			l/s	kW			kW/kW			l/s			
	Nom	Min	Max	Nom	Min	Max	Nom	Nom	Min	Max	Nom	Min	Max	Nom	Nom	Min	Max	Nom	Min	Max	Nom	Min	Max	Nom
38AW 050/80AWH 065 - 80AWX 065	35	2.44	0.61	2.44	2.40	2.40	2.40	0.116	2.80	0.79	3.50	2.25	2.50	2.10	0.134	3.49	0.85	4.20	2.50	2.70	2.40	0.167		
38AW 065/80AWH 065 - 80AWX 065		2.34	0.59	2.34	2.40	2.40	2.40	0.112	3.50	0.70	4.15	2.25	2.65	2.00	0.167	3.72	0.82	4.50	2.50	2.88	2.27	0.178		
38AW 090/80AWH 115 - 80AWX 115		4.04	2.02	4.04	2.02	2.02	2.02	0.193	5.35	2.32	6.12	2.31	2.42	1.94	0.256	6.15	2.79	7.04	2.97	3.09	2.49	0.294		
38AW 115/80AWH 115 - 80AWX 115		4.00	2.00	4.00	2.00	2.00	2.00	0.191	6.00	2.30	7.20	1.90	2.40	1.50	0.287	6.90	2.76	8.10	2.45	3.05	2.30	0.330		
38AW 120/80AWH 150 - 80AWX 150		4.71	0.93	4.71	1.85	1.49	1.85	0.225	5.31	1.28	6.25	2.33	1.97	2.19	0.254	7.54	2.88	10.64	3.17	2.69	3.04	0.360		
38AW 150/80AWH 150 - 80AWX 150		5.54	0.94	5.54	1.74	1.47	1.74	0.265	6.25	1.29	7.65	2.19	1.93	2.13	0.229	8.85	2.89	11.20	2.97	2.65	2.88	0.423		
38AW 050/80AWH 065 - 80AWX 065	45	1.42	0.53	1.42	2.00	2.00	2.00	0.068	2.70	0.60	3.10	1.94	2.15	1.80	0.129	3.04	0.74	3.45	2.08	2.29	1.90	0.145		
38AW 065/80AWH 065 - 80AWX 065		1.37	0.51	1.37	1.90	1.90	1.90	0.065	3.09	0.60	3.65	1.90	2.20	1.70	0.147	3.26	0.72	3.93	2.04	2.35	1.85	0.156		
38AW 090/80AWH 115 - 80AWX 115		3.98	1.99	3.98	1.89	1.89	1.89	0.190	4.53	2.27	4.53	2.10	2.10	2.10	0.216	5.78	2.75	6.94	2.38	2.51	2.04	0.276		
38AW 115/80AWH 115 - 80AWX 115		3.94	1.97	3.94	1.87	1.87	1.87	0.188	4.58	2.29	4.58	2.12	2.12	2.12	0.219	6.80	2.72	8.29	2.00	2.49	1.85	0.325		
38AW 120/80AWH 150 - 80AWX 150		4.64	0.92	4.64	1.73	1.38	1.73	0.222	5.23	1.26	6.16	2.18	1.84	2.05	0.250	6.21	2.66	8.75	2.27	2.18	2.27	0.297		
38AW 150/80AWH 150 - 80AWX 150		5.46	0.93	5.46	1.63	1.37	1.63	0.261	6.16	1.27	7.54	2.05	1.80	1.99	0.294	8.05	2.66	9.30	2.37	2.02	2.16	0.384		
38AW 050/80AWH 065 - 80AWX 065	55	-	-	-	-	-	-	-	1.03	0.62	1.03	1.70	1.70	1.70	0.049	2.43	0.71	3.29	1.78	1.81	1.74	0.116		
38AW 065/80AWH 065 - 80AWX 065		-	-	-	-	-	-	-	1.00	0.60	1.00	1.70	1.70	1.70	0.048	3.10	0.68	3.72	1.64	1.92	1.51	0.148		
38AW 090/80AWH 115 - 80AWX 115		-	-	-	-	-	-	-	4.20	2.10	4.20	1.72	1.72	1.72	0.201	5.20	2.52	6.37	1.70	1.97	1.60	0.248		
38AW 115/80AWH 115 - 80AWX 115		-	-	-	-	-	-	-	4.16	2.08	4.16	1.70	1.70	1.70	0.199	6.24	2.50	7.21	1.57	1.95	1.45	0.298		
38AW 120/80AWH 150 - 80AWX 150		-	-	-	-	-	-	-	4.80	1.16	5.65	1.77	1.50	1.66	0.229	5.79	2.32	7.80	1.86	1.87	2.05	0.277		
38AW 150/80AWH 150 - 80AWX 150		-	-	-	-	-	-	-	5.65	1.16	6.92	1.66	1.46	1.61	0.270	6.73	2.32	8.30	1.96	1.82	1.88	0.322		
38AW 050/80AWH 065 - 80AWX 065	60	-	-	-	-	-	-	-	-	-	-	-	-	-	-	2.40	0.69	3.22	1.52	1.55	1.49	0.115		
38AW 065/80AWH 065 - 80AWX 065		-	-	-	-	-	-	-	-	-	-	-	-	-	-	3.00	0.66	3.48	1.63	1.75	1.34	0.143		
38AW 090/80AWH 115 - 80AWX 115		-	-	-	-	-	-	-	-	-	-	-	-	-	-	4.99	2.31	5.84	1.48	1.70	1.38	0.238		
38AW 115/80AWH 115 - 80AWX 115		-	-	-	-	-	-	-	-	-	-	-	-	-	-	5.72	2.29	6.59	1.35	1.69	1.25	0.273		
38AW 120/80AWH 150 - 80AWX 150		-	-	-	-	-	-	-	-	-	-	-	-	-	-	5.34	2.26	7.20	1.61	1.72	1.78	0.255		
38AW 150/80AWH 150 - 80AWX 150		-	-	-	-	-	-	-	-	-	-	-	-	-	-	6.07	2.25	7.49	1.65	1.47	1.58	0.290		

LWT °C	Outside air dry-bulb (wet-bulb) temperature, °C																							
	-3(-4)							0 (-1)							2 (1)									
	Qh			COP			q	Qh			COP			q	Qh			COP			q			
	kW			kW/kW			l/s	kW			kW/kW			l/s	kW			kW/kW			l/s			
	Nom	Min	Max	Nom	Min	Max	Nom	Nom	Min	Max	Nom	Min	Max	Nom	Nom	Min	Max	Nom	Min	Max	Nom	Min	Max	Nom
38AW 050/80AWH 065 - 80AWX 065	35	3.60	0.96	4.46	2.80	2.95	2.70	0.172	3.80	1.00	4.70	3.00	3.22	2.90	0.182	3.90	1.15	4.90	3.10	3.27	3.00	0.186		
38AW 065/80AWH 065 - 80AWX 065		4.28	0.92	5.05	2.80	3.12	2.49	0.204	4.64	1.00	5.50	3.00	3.30	2.66	0.222	4.88	1.05	5.80	3.10	3.35	2.71	0.233		
38AW 090/80AWH 115 - 80AWX 115		6.33	2.87	7.24	3.23	3.30	2.41	0.302	6.95	3.15	7.96	3.44	3.48	2.89	0.332	7.22	3.27	8.26	3.58	3.59	3.00	0.345		
38AW 115/80AWH 115 - 80AWX 115		7.10	2.84	8.30	2.66	3.27	2.48	0.339	7.80	3.12	8.50	2.83	3.44	2.65	0.373	8.10	3.24	9.00	2.95	3.55	2.76	0.387		
38AW 120/80AWH 150 - 80AWX 150		7.56	3.08	10.70	3.19	2.74	3.04	0.361	7.60	3.29	10.89	3.21	2.77	3.10	0.363	8.50	3.39	11.57	3.70	2.84	3.15	0.406		
38AW 150/80AWH 150 - 80AWX 150		8.88	3.09	11.21	2.99	2.70	2.88	0.424	8.93	3.29	11.40	3.01	2.74	2.93	0.427	9.50	3.39	12.12	3.15	2.80	2.98	0.454		
38AW 050/80AWH 065 - 80AWX 065	45	3.10	0.84	3.89	2.29	2.48	2.20	0.148	3.24	0.91	4.23	2.45	2.62	2.30	0.155	3.40	0.96	4.45	2.55	2.66	2.35	0.162		
38AW 065/80AWH 065 - 80AWX 065		3.75	0.81	4.44	2.25	2.54	2.03	0.179	4.07	0.88	4.81	2.40	2.68	2.17	0.194	4.28	0.92	5.06	2.50	2.73	2.21	0.205		
38AW 090/80AWH 115 - 80AWX 115		5.87	2.79	7.04	2.50	2.71	2.23	0.280	6.72	3.19	8.06	2.66	2.85	2.38	0.321	7.14	3.39	8.57	2.77	2.95	2.48	0.341		
38AW 115/80AWH 115 - 80AWX 115		6.90	2.76	8.80	2.19	2.68	2.04	0.330	7.90	3.16	10.00	2.33	2.82	2.19	0.377	8.40	3.36	10.70	2.43	2.92	2.28	0.401		
38AW 120/80AWH 150 - 80AWX 150		6.23	2.85	9.50	2.29	2.22	2.28	0.298	6.27	3.03	9.76	2.31	2.25	2.30	0.299	7.50	3.13	11.41	2.70	2.30	2.68	0.358		
38AW 150/80AWH 150 - 80AWX 150		8.07	2.84	10.09	2.39	2.06	2.30	0.385	8.11	3.03	10.37	2.41	2.09	2.34	0.388	9.10	3.12	12.11	2.60	2.14	2.55	0.435		
38AW 050/80AWH 065 - 80AWX 065	55	2.74	0.80	3.72	1.92	1.96	1.86	0.131	2.98	0.87	4.03	2.03	2.07	1.95	0.142	3.13	0.92	4.24	2.07	2.11	1.98	0.15		
38AW 065/80AWH 065 - 80AWX 065		3.55	0.77	4.20	1.81	2.08	1.66	0.17	3.86	0.83	4.56	2.00	2.19	1.77	0.184	4.06	0.88	4.80	2.01	2.23	1.80	0.194		
38AW 090/80AWH 115 - 80AWX 115		5.83	2.83	7.14	1.86	2.13	1.75	0.279	6.48	3.14	7.94	1.98	2.24	1.87	0.31	6.85	3.32	8.38	2.07	2.31	1.95	0.327		
38AW 115/80AWH 115 - 80AWX 115		7.00	2.80	7.98	1.72	2.10	1.60	0.334	7.78	3.11	9.03	1.83	2.22	1.71	0.372	8.22	3.29	9.50	1.91	2.29	1.79	0.393		
38AW 120/80AWH 150 - 80AWX 150		6.35	2.48	8.56	1.87	1.91	2.06	0.304	6.39	2.65	8.79	1.88	1.93	2.08	0.305	7.49	2.73	8.89	2.28	1.98	2.25	0.358		
38AW 150/80AWH 150 - 80AWX 150		6.75	2.48	9.10	1.98	1.86	1.90	0.322	6.79	2.64	9.35	2.05	1.89	1.95	0.324	7.96	2.72	9.83	2.40	1.95	2.14	0.38		
38AW 050/80AWH 065 - 80AWX 065	60	2.70	0.78	3.68	1.65	1.68	1.59	0.129	2.94	0.85	4.00	1.74	1.77	1.67	0.14	3.09	0.90	4.20	1.77	1.80	1.69	0.148		
38AW 065/80AWH 065 - 80AWX 065		3.39	0.75	3.92	1.78	1.90	1.47	0.162	3.67	0.81	4.26	1.83	1.95	1.57	0.176	3.87	0.85	4.48	1.86	1.98	1.60	0.185		
38AW 090/80AWH 115 - 80AWX 115		5.44	2.52	6.37	1.63	1.84	1.52	0.26	6.10	2.83	7.14	1.73	1.93	1.61	0.291	6.27	2.91	7.34	1.80	2.00	1.68	0.3		
38AW 115/80AWH 115 - 80AWX 115		6.24	2.50	7.46	1.49	1.83	1.41	0.298	7.00	2.80	8.00	1.58	1.91	1.50	0.334	7.20	2.88	8.20	1.65	1.98	1.54	0.344		
38AW 120/80AWH 150 - 80AWX 150		5.86	2.42	7.89	1.62	1.76	1.79	0.28	5.90	2.57	8.11	1.63	1.78	1.81	0.282	7.00	2.65	8.31	2.04	1.82	2.02	0.334		
38AW 150/80AWH 150 - 80AWX 150		6.09	2.41	8.21	1.66	1.50	1.59	0.291	6.12	2.57	8.44	1.72	1.52	1.64	0.293	7.77	2.65	9.60	2.32	1.86	2.07	0.371		

## HEATING CAPACITIES IN ACCORDANCE WITH EN14511-3:2013

### 38AW/80AW units

38AW/80AW units	LWT °C	Outside air dry-bulb (wet-bulb) temperature, °C																							
		7 (6)						10 (9)						20 (19)											
		Qh			COP			q	Qh			COP			q	Qh			COP			q			
		kW			kW/kW			l/s	kW			kW/kW			l/s	kW			kW/kW			l/s			
	Nom	Min	Max	Nom	Min	Max	Nom	Nom	Min	Max	Nom	Min	Max	Nom	Nom	Min	Max	Nom	Min	Max	Nom	Min	Max	Nom	
38AW 050 / 80AWH 065 - 80AWX 065	35	5.01	1.46	6.30	4.15	4.18	4.00	0.239	5.43	1.59	7.00	4.48	4.56	4.20	0.259	6.86	2.00	8.70	5.74	5.85	5.40	0.328			
38AW 065 / 80AWH 065 - 80AWX 065		6.55	1.40	8.00	4.15	4.28	3.53	0.313	7.06	1.52	9.00	4.48	4.67	3.85	0.337	8.91	1.92	10.90	5.74	5.99	5.10	0.426			
38AW 090 / 80AWH 115 - 80AWX 115		9.27	4.64	11.73	4.48	4.76	4.18	0.443	10.20	5.11	12.90	4.69	5.00	4.38	0.487	12.90	6.46	16.32	5.14	5.46	4.80	0.616			
38AW 115 / 80AWH 115 - 80AWX 115		11.50	4.60	13.40	4.10	4.71	3.91	0.549	12.65	5.06	14.85	4.29	4.95	4.10	0.604	16.00	6.40	19.00	4.70	5.41	4.48	0.764			
38AW 120 / 80AWH 150 - 80AWX 150		12.00	6.00	15.02	4.65	4.06	4.57	0.573	12.86	6.50	17.47	5.41	4.50	4.99	0.614	16.14	7.70	20.24	6.54	5.38	6.00	0.771			
38AW 150 / 80AWH 150 - 80AWX 150		15.01	5.99	16.05	4.30	4.01	4.25	0.717	16.13	6.49	18.66	4.96	4.44	4.70	0.771	20.24	7.69	21.12	6.00	5.31	5.49	0.967			
38AW 050 / 80AWH 065 - 80AWX 065	45	4.37	1.28	5.92	3.41	3.60	2.80	0.209	4.74	1.39	6.42	3.74	3.90	3.10	0.227	5.99	1.75	8.11	4.79	4.95	4.01	0.286			
38AW 065 / 80AWH 065 - 80AWX 065		5.70	1.23	7.20	3.34	3.49	2.87	0.272	6.19	1.34	7.97	3.65	3.81	3.14	0.296	7.82	1.69	10.07	4.67	4.88	4.02	0.373			
38AW 090 / 80AWH 115 - 80AWX 115		8.70	4.56	11.53	3.45	3.83	3.37	0.416	9.57	5.02	12.68	3.70	4.03	3.53	0.457	12.09	6.34	16.01	4.05	4.40	3.86	0.578			
38AW 115 / 80AWH 115 - 80AWX 115		11.30	4.52	13.52	3.32	3.79	3.15	0.540	12.43	4.97	14.60	3.46	3.99	3.30	0.594	15.70	6.28	18.80	3.78	4.35	3.60	0.750			
38AW 120 / 80AWH 150 - 80AWX 150		11.20	5.54	13.90	3.70	3.31	3.40	0.535	11.97	6.01	16.17	4.07	3.67	3.78	0.572	15.03	7.12	18.72	4.92	4.38	4.58	0.718			
38AW 150 / 80AWH 150 - 80AWX 150		14.02	5.53	15.76	3.40	3.07	3.12	0.670	14.92	5.99	16.42	3.78	3.40	3.62	0.713	18.72	7.10	20.65	4.58	4.07	4.21	0.894			
38AW 050 / 80AWH 065 - 80AWX 065	55	4.17	1.22	5.65	2.64	2.69	2.58	0.199	4.53	1.32	6.13	2.88	2.94	2.81	0.216	5.72	1.67	7.74	3.69	3.76	3.61	0.273			
38AW 065 / 80AWH 065 - 80AWX 065		5.43	1.17	6.70	2.64	2.85	2.35	0.259	5.86	1.27	7.30	2.98	3.11	2.56	0.28	7.41	1.60	9.25	3.82	3.99	3.40	0.354			
38AW 090 / 80AWH 115 - 80AWX 115		8.00	4.18	10.56	2.62	3.00	2.64	0.382	8.80	4.60	11.61	2.74	3.16	2.77	0.42	10.74	5.61	14.18	3.00	3.45	3.03	0.513			
38AW 115 / 80AWH 115 - 80AWX 115		10.35	4.14	11.40	2.59	2.97	2.47	0.495	11.39	4.55	12.35	2.71	3.13	2.59	0.544	13.90	5.56	14.73	2.97	3.42	2.83	0.664			
38AW 120 / 80AWH 150 - 80AWX 150		10.81	4.84	13.25	3.08	2.85	3.01	0.517	11.76	5.24	15.56	3.32	3.16	3.24	0.562	14.76	6.22	17.77	4.02	3.78	3.92	0.705			
38AW 150 / 80AWH 150 - 80AWX 150		12.02	4.83	14.83	3.19	2.73	2.85	0.574	13.07	5.24	17.41	3.44	2.95	3.02	0.624	16.40	6.21	19.88	4.16	3.50	3.60	0.784			
38AW 050 / 80AWH 065 - 80AWX 065	60	4.12	1.19	5.60	2.26	2.30	2.21	0.197	4.48	1.29	6.09	2.47	2.51	2.41	0.214	5.67	1.63	7.50	3.16	3.22	3.00	0.271			
38AW 065 / 80AWH 065 - 80AWX 065		5.15	1.13	6.00	2.42	2.53	2.08	0.246	5.59	1.23	6.50	2.64	2.76	2.30	0.267	7.06	1.55	8.45	3.39	3.54	3.00	0.337			
38AW 090 / 80AWH 115 - 80AWX 115		7.65	3.83	9.67	2.28	2.59	2.28	0.366	8.42	4.21	10.64	2.39	2.73	2.39	0.402	9.30	4.65	11.76	2.61	2.98	2.61	0.444			
38AW 115 / 80AWH 115 - 80AWX 115		9.48	3.79	10.89	2.24	2.57	2.13	0.453	10.43	4.17	11.52	2.34	2.70	2.23	0.498	11.52	4.61	12.16	2.56	2.95	2.44	0.551			
38AW 120 / 80AWH 150 - 80AWX 150		10.52	4.70	12.89	2.85	2.63	2.79	0.503	11.44	5.10	15.14	3.07	2.91	3.00	0.547	14.04	6.04	16.89	3.72	3.48	3.63	0.671			
38AW 150 / 80AWH 150 - 80AWX 150		11.67	4.69	14.39	3.00	2.61	2.72	0.557	12.69	5.09	16.90	3.20	2.82	2.88	0.606	15.59	6.03	18.89	3.80	3.34	3.44	0.745			

#### Legend

<b>LWT</b>	Leaving Water Temperature, °C
<b>Qh</b>	Heating Capacity, kW
<b>Nom</b>	Nominal
<b>Min</b>	Minimum
<b>Max</b>	Maximum
<b>COP</b>	Coefficient of Performance
<b>q</b>	Condenser water flow rate, l/s

#### Application Data

Standard units, refrigerant: R-410A  
 Condenser entering/leaving water temperature difference: 5 K  
 Condenser fluid: water  
 Fouling Factor: 0.02 K/W

Performance in accordance with EN 14511-3: 2013

**COOLING CAPACITIES IN ACCORDANCE WITH EN14511-3:2013**

**38AW/80AW units**

	LWT oC	Outside air Temperature, oC																				
		5						15						25								
		Qc			EER			q	Qc			EER			q	Qc			EER			q
		kW			kW/kW			l/s	kW			kW/kW			l/s	kW			kW/kW			l/s
	Nom	Min	Max	Nom	Min	Max	Nom	Nom	Min	Max	Nom	Min	Max	Nom	Nom	Min	Max	Nom	Min	Max	Nom	
38AW 050 / 80AWX 065	5	4.57	1.21	5.20	7.74	8.83	7.44	0.219	4.16	1.11	4.73	4.95	5.57	4.76	0.199	3.75	1.00	4.26	3.44	3.88	3.31	0.179
38AW 065 / 80AWX 065		5.98	1.61	8.28	7.71	8.56	7.06	0.286	5.44	1.47	7.54	4.92	5.36	4.50	0.26	4.90	1.32	6.79	3.43	3.74	3.13	0.234
38AW 090 / 80AWX 115		7.02	3.65	8.19	5.46	6.47	5.22	0.336	6.46	3.36	7.54	4.59	5.45	4.40	0.309	6.02	3.14	7.02	3.64	4.40	3.48	0.288
38AW 115 / 80AWX 115		8.03	3.62	10.60	5.12	6.41	4.13	0.384	7.39	3.33	9.76	4.31	5.39	3.48	0.353	6.88	3.10	9.28	3.41	4.36	2.82	0.329
38AW 120 / 80AWX 150		12.15	6.19	15.44	6.05	4.67	5.20	0.58	11.52	5.82	14.56	5.27	4.25	4.53	0.55	10.54	5.45	13.43	4.24	3.72	3.65	0.504
38AW 150 / 80AWX 150		15.04	6.20	15.39	4.81	4.79	4.71	0.719	14.05	5.82	14.37	4.36	4.36	4.27	0.671	13.08	5.45	13.36	3.81	3.73	3.65	0.625
38AW 050 / 80AWX 065	7	4.94	1.18	5.61	7.98	9.74	7.62	0.236	4.50	1.07	5.11	5.27	6.43	5.03	0.215	4.05	0.97	4.60	3.65	4.46	3.49	0.194
38AW 065 / 80AWX 065		6.44	1.54	8.49	7.98	9.74	7.36	0.308	5.87	1.40	7.73	5.27	6.43	4.86	0.28	5.29	1.26	6.97	3.65	4.46	3.37	0.253
38AW 090 / 80AWX 115		7.46	3.88	8.70	5.83	6.87	5.58	0.357	6.87	3.57	8.01	4.90	5.78	4.69	0.328	6.40	3.33	7.46	3.86	4.68	3.70	0.306
38AW 115 / 80AWX 115		8.53	3.84	11.26	5.47	6.80	4.39	0.408	7.85	3.54	10.37	4.60	5.73	3.69	0.375	7.31	3.30	9.86	3.62	4.63	3.00	0.349
38AW 120 / 80AWX 150		12.95	6.63	16.43	6.20	4.93	5.34	0.619	12.25	6.23	15.53	5.45	4.48	4.69	0.585	11.25	5.83	14.27	4.47	3.92	3.85	0.537
38AW 150 / 80AWX 150		15.58	6.63	16.23	5.11	5.03	4.94	0.744	14.64	6.23	15.25	4.65	4.57	4.50	0.7	13.70	5.83	14.27	4.06	4.00	3.93	0.655
38AW 050 / 80AWX 065	10	5.48	1.12	6.23	8.34	11.11	7.88	0.262	5.00	1.02	5.68	5.76	7.73	5.44	0.239	4.51	0.92	5.12	3.97	5.33	3.75	0.215
38AW 065 / 80AWX 065		7.14	1.42	8.80	8.39	11.52	7.82	0.341	6.51	1.29	8.02	5.79	8.05	5.41	0.311	5.88	1.16	7.23	3.99	5.54	3.73	0.281
38AW 090 / 80AWX 115		8.12	4.22	9.47	6.38	7.47	6.10	0.388	7.47	3.89	8.71	5.37	6.29	5.14	0.357	6.96	3.62	8.12	4.20	5.08	4.02	0.333
38AW 115 / 80AWX 115		9.28	4.18	12.26	5.98	7.40	4.77	0.443	8.54	3.85	11.28	5.04	6.22	4.02	0.408	7.96	3.59	10.73	3.94	5.03	3.26	0.38
38AW 120 / 80AWX 150		14.16	7.28	17.89	6.44	5.31	5.55	0.677	13.34	6.84	16.99	5.72	4.83	4.93	0.637	12.31	6.40	15.68	4.82	4.22	4.16	0.588
38AW 150 / 80AWX 150		16.39	7.27	17.48	5.56	5.38	5.30	0.783	15.52	6.83	16.56	5.08	4.90	4.83	0.742	14.64	6.39	15.62	4.45	4.28	4.24	0.699
38AW 050 / 80AWX 065	15	6.39	1.02	7.26	8.93	13.39	8.32	0.305	5.83	0.93	6.62	6.56	9.90	6.11	0.278	5.26	0.84	5.98	4.50	6.78	4.19	0.251
38AW 065 / 80AWX 065		8.31	1.22	9.32	9.06	14.49	8.59	0.397	7.59	1.11	8.50	6.66	10.73	6.32	0.363	6.85	1.01	7.68	4.56	7.35	4.33	0.327
38AW 090 / 80AWX 115		4.80	4.80	4.80	8.47	8.47	8.47	0.229	8.48	4.41	9.89	6.14	7.13	5.88	0.405	7.90	4.11	9.21	4.76	5.76	4.56	0.378
38AW 115 / 80AWX 115		4.75	4.75	4.75	8.38	8.38	8.38	0.227	9.70	4.37	12.81	5.76	7.06	4.55	0.463	9.03	4.07	12.18	4.47	5.70	3.69	0.432
38AW 120 / 80AWX 150		16.17	8.36	19.90	6.83	5.94	5.90	0.773	15.17	7.85	18.94	6.16	5.40	5.33	0.725	14.08	7.35	18.04	5.40	4.72	4.67	0.673
38AW 150 / 80AWX 150		17.75	8.34	19.57	6.32	5.98	5.88	0.848	16.99	7.84	18.75	5.79	5.44	5.39	0.812	16.20	7.33	17.88	5.09	4.76	4.74	0.774
38AW 050 / 80AWX 065	18	6.93	0.96	7.88	9.28	14.75	8.58	0.331	6.33	0.88	7.19	7.05	11.20	6.52	0.302	5.72	0.79	6.50	4.81	7.64	4.45	0.273
38AW 065 / 80AWX 065		9.01	1.10	9.63	9.46	16.26	9.04	0.431	8.23	1.01	8.79	7.18	12.35	6.86	0.393	7.44	0.91	7.94	4.90	8.43	4.69	0.355
38AW 090 / 80AWX 115		5.14	5.14	5.14	9.07	9.07	9.07	0.245	9.09	4.73	10.60	6.61	7.63	6.32	0.434	8.47	4.41	9.87	5.10	6.17	4.88	0.405
38AW 115 / 80AWX 115		5.09	5.09	5.09	8.98	8.98	8.98	0.243	10.39	4.68	13.72	6.20	7.55	4.87	0.496	9.68	4.37	13.05	4.78	6.11	3.95	0.462
38AW 120 / 80AWX 150		17.38	9.01	20.98	7.06	6.32	6.11	0.83	16.26	8.46	20.39	6.43	5.75	5.57	0.777	15.15	7.92	19.45	5.75	5.02	4.98	0.724
38AW 150 / 80AWX 150		18.56	8.99	20.83	6.77	6.33	6.24	0.887	17.87	8.44	20.06	6.22	5.76	5.73	0.854	17.14	7.89	19.24	5.47	5.04	5.04	0.819

## COOLING CAPACITIES IN ACCORDANCE WITH EN14511-3:2013

### 38AW/80AW units

	LWT oC	Outside air Temperature, oC													
		35							45						
		Qc			EER			q	Qc			EER			q
		kW			kW/kW			l/s	kW			kW/kW			l/s
		Nom	Min	Max	Nom	Min	Max	Nom	Nom	Min	Max	Nom	Min	Max	Nom
38AW 050 / 80AWX 065	5	3.29	0.88	3.79	2.45	2.77	2.37	0.157	3.5	0.77	4.01	1.51	2	1.41	0.167
38AW 065 / 80AWX 065		4.4	1.18	6.03	2.45	2.67	2.23	0.21	4.61	1.03	6.14	1.44	1.92	1.26	0.22
38AW 090 / 80AWX 115		5.6	2.91	6.53	2.89	3.53	2.77	0.268	5.04	2.62	5.87	2.5	3.04	2.39	0.241
38AW 115 / 80AWX 115		6.4	2.88	8.63	2.71	3.49	2.28	0.306	5.76	2.59	7.77	2.35	3.01	1.99	0.275
38AW 120 / 80AWX 150		9.72	4.89	12.26	3.16	2.87	2.86	0.465	8.99	4.23	11.14	2.33	2.22	2.26	0.429
38AW 150 / 80AWX 150		12.02	4.89	12.3	2.98	2.94	2.92	0.574	10.94	4.24	11.17	2.35	2.28	2.3	0.523
38AW 050 / 80AWX 065	7	3.57	0.86	4.09	2.60	3.17	2.48	0.171	3.14	0.75	3.57	1.87	2.29	1.79	0.15
38AW 065 / 80AWX 065		4.73	1.12	6.19	2.60	3.17	2.4	0.226	4.1	0.98	5.4	1.87	2.29	1.73	0.196
38AW 090 / 80AWX 115		5.95	3.09	6.94	3.07	3.74	2.94	0.284	5.35	2.78	6.24	2.66	3.23	2.54	0.256
38AW 115 / 80AWX 115		6.80	3.06	9.17	2.88	3.71	2.42	0.325	6.12	2.75	8.25	2.49	3.19	2.11	0.292
38AW 120 / 80AWX 150		10.30	5.23	13.13	3.41	3.02	3.02	0.492	9.42	4.53	11.93	2.56	2.34	2.38	0.45
38AW 150 / 80AWX 150		12.60	5.23	13.13	3.17	3.08	3.08	0.602	11.47	4.53	11.93	2.5	2.39	2.43	0.548
38AW 050 / 80AWX 065	10	3.99	0.82	4.54	2.82	3.78	2.65	0.191	2.6	0.71	2.91	2.42	2.72	2.36	0.124
38AW 065 / 80AWX 065		5.23	1.04	6.43	2.82	3.93	2.65	0.25	3.35	0.9	4.29	2.53	2.83	2.43	0.16
38AW 090 / 80AWX 115		6.48	3.36	7.55	3.34	4.07	3.19	0.309	5.83	3.03	6.79	2.89	3.51	2.76	0.278
38AW 115 / 80AWX 115		7.4	3.33	9.98	3.13	4.03	2.63	0.354	6.66	3	8.98	2.71	3.47	2.3	0.318
38AW 120 / 80AWX 150		11.17	5.74	14.43	3.77	3.25	3.26	0.534	10.07	4.97	13.11	2.9	2.52	2.57	0.481
38AW 150 / 80AWX 150		13.47	5.73	14.38	3.46	3.3	3.32	0.643	12.26	4.96	13.06	2.72	2.56	2.62	0.586
38AW 050 / 80AWX 065	15	4.68	0.75	5.28	3.18	4.79	2.92	0.224	1.7	0.66	1.82	3.34	3.45	3.32	0.081
38AW 065 / 80AWX 065		6.05	0.9	6.84	3.18	5.2	3.06	0.289	2.09	0.78	2.44	3.63	3.74	3.59	0.1
38AW 090 / 80AWX 115		7.35	3.82	8.57	3.78	4.61	3.62	0.351	6.61	3.44	7.71	3.27	3.98	3.13	0.316
38AW 115 / 80AWX 115		8.4	3.78	11.33	3.55	4.57	2.98	0.401	7.56	3.4	10.2	3.07	3.94	2.6	0.361
38AW 120 / 80AWX 150		12.63	6.59	16.6	4.38	3.64	3.66	0.603	11.15	5.7	15.08	3.47	2.82	2.89	0.533
38AW 150 / 80AWX 150		14.92	6.57	16.45	3.95	3.67	3.72	0.713	13.57	5.68	14.94	3.09	2.85	2.93	0.648
38AW 050 / 80AWX 065	18	5.10	0.71	5.72	3.40	5.4	3.08	0.244	1.16	0.62	1.16	3.89	3.89	3.89	0.055
38AW 065 / 80AWX 065		6.55	0.81	7.09	3.40	5.96	3.31	0.313	1.33	0.71	1.33	4.29	4.29	4.29	0.064
38AW 090 / 80AWX 115		7.88	4.09	9.18	4.05	4.94	3.88	0.376	7.08	3.68	8.26	3.5	4.26	3.35	0.339
38AW 115 / 80AWX 115		9.00	4.05	12.14	3.80	4.89	3.19	0.43	8.1	3.65	10.92	3.29	4.21	2.79	0.387
38AW 120 / 80AWX 150		13.50	7.1	17.9	4.74	3.87	3.9	0.645	11.8	6.14	16.26	3.82	3	3.08	0.564
38AW 150 / 80AWX 150		15.79	7.07	17.7	4.24	3.89	3.96	0.754	14.35	6.12	16.08	3.31	3.02	3.12	0.686

**Legend**

<b>LWT</b>	Leaving Water Temperature, °C
<b>Qc</b>	Cooling Capacity, kW
<b>Nom</b>	Nominal
<b>Min</b>	Minimum
<b>Max</b>	Maximum
<b>EER</b>	Energy Efficiency Ratio, kW/kW
<b>q</b>	Evaporator water flow rate, l/s

**Application Data**

Standard units, refrigerant: R-410A  
 Evaporator entering/leaving water temperature difference: 5 K  
 Evaporator fluid: Water  
 Fouling Factor: 0.m<sup>2</sup> K/W

Performance in accordance with EN 14511-3:2013

## PHYSICAL DATA, TWO-ZONE KIT

<b>Dimensions</b>		
Unit H x L x D	mm	485 x 450 x 330
Packaging H x L x D	mm	565 x 530 x 410
<b>Unit weight</b>		
Gross weight	kg	22
	kg	27
<b>Hydraulic data</b>		
Water connections	in	1" male
Operating water pressure	kPa (bar)	100 (1)
Maximum pressure	kPa (bar)	300 (3)
<b>Hydraulic components</b>		
Pump	Two water-cooled pumps, variable speed, 75 kPa static pressure	
Three-way valve	One modulating valve, 6.3 Kv, switching time (90°) 240 seconds, 230-V, 3-point SPDT actuator	
Collector volume	l	1
Draining valve	√	
<b>Outside air operating range, heating and cooling</b>		
See Comfort module		

## ELECTRICAL DATA, TWO-ZONE KIT

<b>Power supply</b>	V-ph-Hz	230-1-50
<b>Voltage range</b>	V	207-253
<b>Power input</b>	W	260

## SOUND LEVELS, TWO-ZONE KIT

		Without comfort module	With comfort module
<b>Sound power level</b>	dB(A)	44	46
<b>Sound pressure level*</b>	dB(A)	30	32

\* Measured at 2 m distance, in accordance with UNI EN ISO 3741.

## AVAILABLE STATIC PRESSURE, TWO-ZONE KIT

Zone with modulating valve

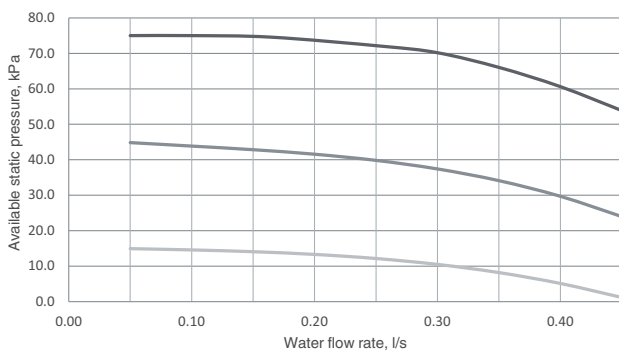

Zone without modulating valve

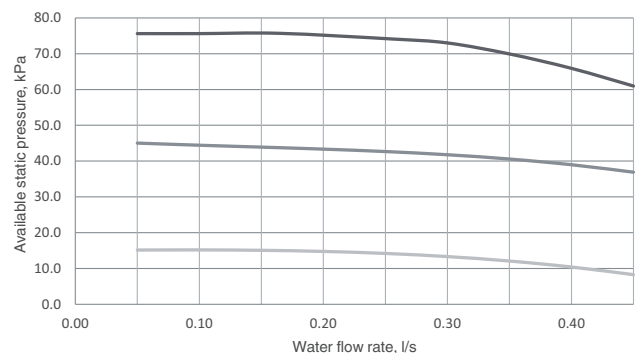

- High water pump speed
- Medium water pump speed
- Low water pump speed

## PRESSURE, CIRCULATING PUMP 80AW

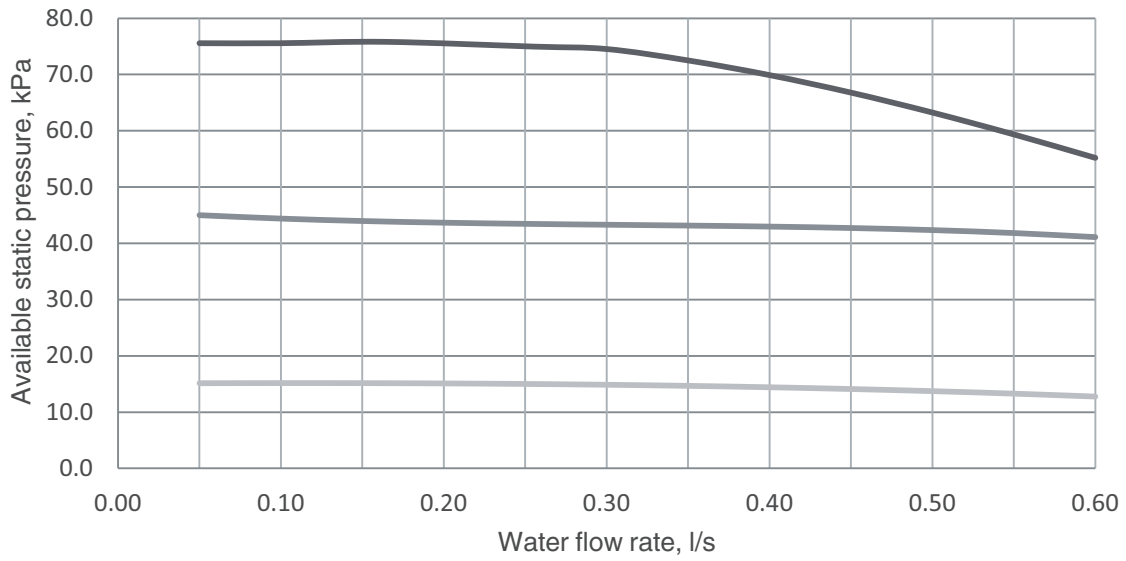

- High water pump speed
- Medium water pump speed
- Low water pump speed

## DIMENSIONS (MM), TWO-ZONE KIT

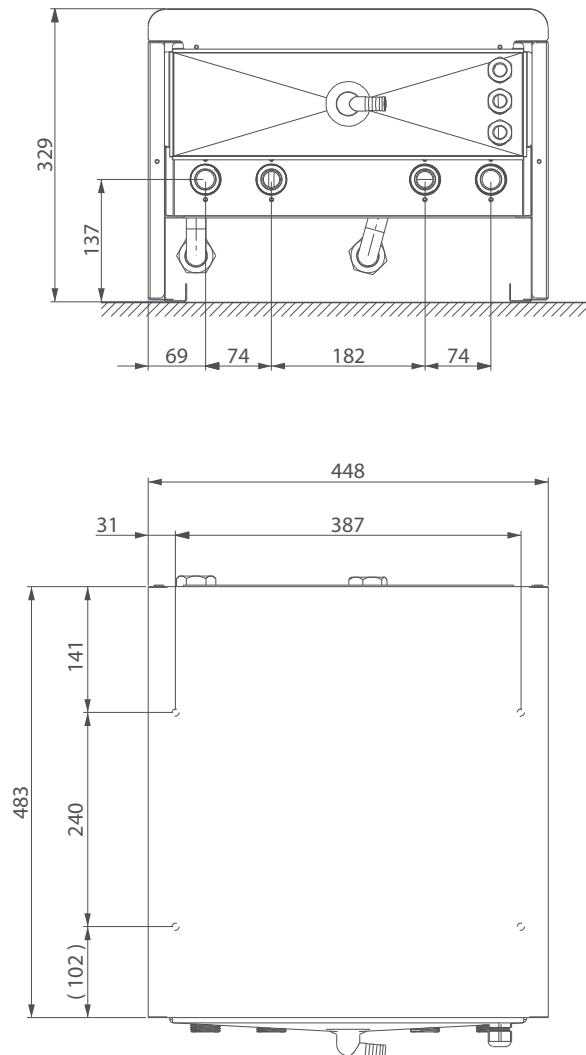

**CLEARANCES (MM), TWO-ZONE KIT**

**Connected to the comfort module**

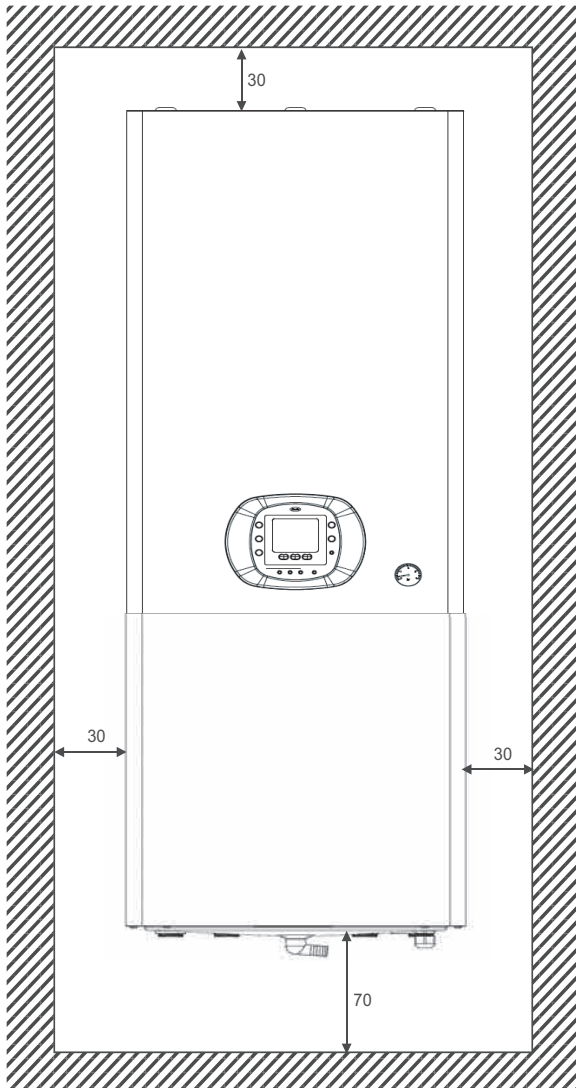

**Detached from the comfort module**

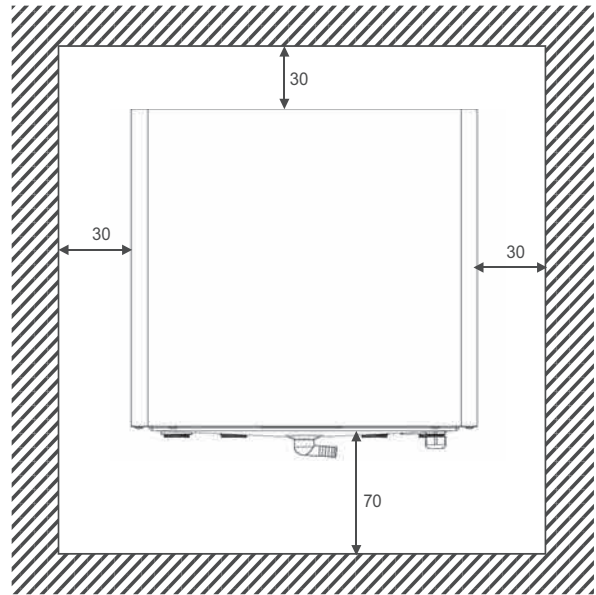

## PHYSICAL DATA, DOMESTIC HOT WATER (DHW) MODULE

		60STS 020E03	60STD 020E03	60STS 030E03	60STD 030E03
Water tank size	l	212	212	291	291
Number of coils		1	2	1	2
Electric heater backup	kW	3.3, single-phase	3.3, single-phase	3.3, single-phase	3.3, single-phase
Voltage	V	230 ± 10%	230 ± 10%	230 ± 10%	230 ± 10%
Operating temperature range	°C	5 to 95	5 to 95	5 to 95	5 to 95
Operating pressure DHW module	bar	0 to 10	0 to 10	0 to 10	0 to 10
Operating pressure heat exchangers	bar	0 to 6	0 to 6	0 to 6	0 to 6
Ambient operating temperature range	°C	5 to 45 °C	5 to 45 °C	5 to 45 °C	5 to 45 °C
Storage temperature range	°C	-20 to +75 °C	-20 to +75 °C	-20 to +75 °C	-20 to +75 °C
Lower heat exchanger	m <sup>2</sup>	1.2	1.2	1.5	1.5
Upper heat exchanger	m <sup>2</sup>		0.5		1.1
Diameter	mm	600	600	600	600
Height	mm	1215	1215	1615	1615



## ELECTRICAL DATA, DOMESTIC HOT WATER (DHW) MODULE

Model	60ST-020/60ST-030	
Maximum operating current	A	15
Power supply	V-ph-Hz	230-1-50
Voltage range	V	207-253

Cable type and size (4): H05VV-F	3G x 2.5 mm <sup>2</sup>
Cable type and size (5): FROH2R	2 x 1 mm <sup>2</sup>
Cable type and size (6): FROH2R	2 x 0.5 mm <sup>2</sup>

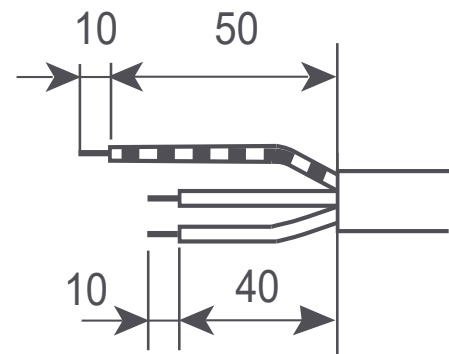
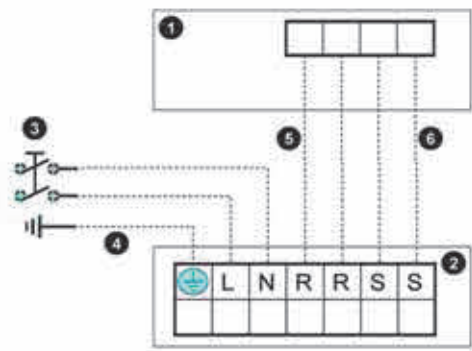
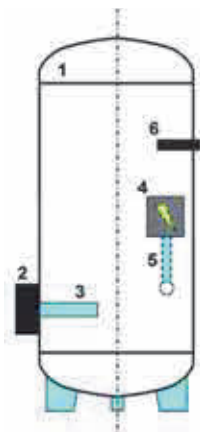

- B Main unit
- C Domestic hot water tank control box
- D Circuit breaker
- E Mains supply connecting cable
- F Booster heater activation cable
- G Temperature sensor cable
- ⏏ Earth
- L Live power supply
- N Neutral power supply

**DIMENSIONS (MM), DOMESTIC HOT WATER (DHW) MODULE**

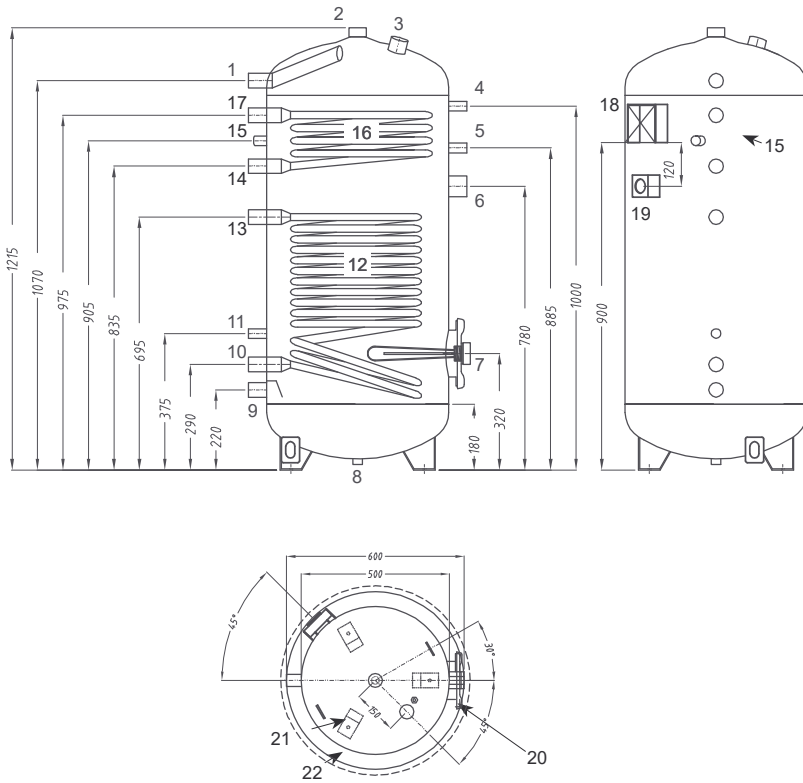

**Legend**

- 1 Water outlet (hot water)
- 2 Water outlet (hot water)
- 3 Anode connection
- 4 Connection for temperature sensor/pressure gauge
- 5 Connection for temperature sensor/pressure gauge
- 6 Connection
- 7 Electric heater (flange-mounted)
- 8 Fastening hole
- 9 Water inlet (cold water)
- 10 Lower coil outlet
- 11 Connection for temperature sensor/pressure gauge
- 12 Lower coil
- 13 Lower coil inlet
- 14 Upper coil outlet
- 15 Temperature sensor
- 16 Upper coil
- 17 Upper coil inlet
- 18 Control box
- 19 Cable holder
- 20 M6 nut earth
- 21 Insulation
- 22 Aesthetical cover

**TYPICAL INSTALLATION DIAGRAMS, DOMESTIC HOT WATER (DHW) MODULE**

**System without solar panel and tanks**  
60STS 020E03 or 60STS 030E03

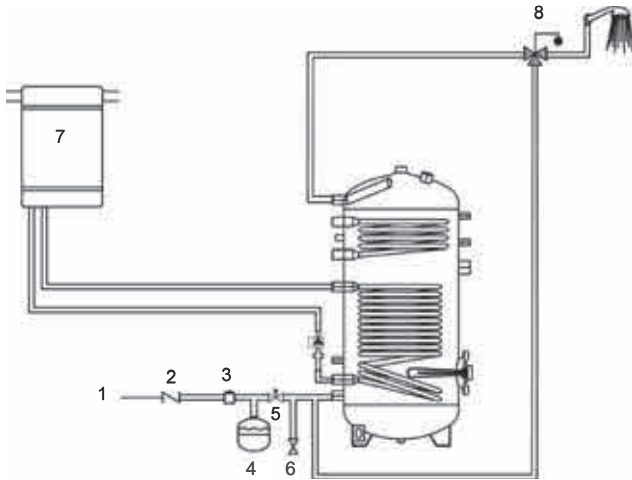

**System with solar panel and tanks**  
60STD 020E03 or 60STD 030E03

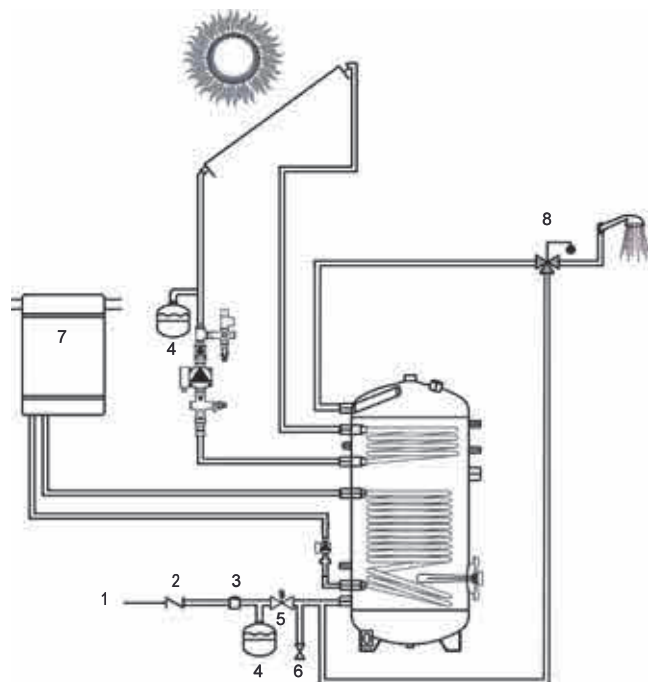

**Legend**

- 1 Water circuit
- 2 Check valve
- 3 Pressure reduction device
- 4 Expansion tank
- 5 Safety valve
- 6 Drain valve
- 7 Boiler
- 8 Thermostatic valve