

COANDA EFFECT CASSETTE

- Optimised Coanda Effect diffusion
- Indoor comfort
- Air quality
- Responsiveness of the system and individual adjustment
- Low energy consumption
- Acoustic comfort
- Design
- Ease of maintenance

42KY

Cooling capacity 1-6 kW
Heating capacity 2-10 kW

Energy performance, comfort and indoor air quality: Carrier's new 42KY cassette is the all-in-one solution to meet heating and cooling requirements for commercial buildings and provide optimum comfort for users.

This low consumption (LEC) variable speed active comfort unit makes it possible to adapt the indoor temperature automatically and independently to the preferences of occupants with very quick response times.

Optimisation of the Coanda Effect diffusion, to meet the requirements of the standard NF EN ISO 7730, ensures perfect control of thermal phenomena that can cause discomfort. Carrier's new 42KY cassette makes it possible to eliminate the draughts that are felt with sweeping diffusion systems or those with direct airflow onto the occupant.

Eco-designed product that is 90% recyclable. The 42KY cassette has been developed to limit its impact on the environment throughout its life cycle.



CARRIER participates in the ECP programme for FC/FCP
Check ongoing validity of certificate:
www.eurovent-certification.com

OPERATION AND ADVANTAGES

Use

The air treatment unit is fitted within the suspended ceiling, at the edge of the room, with the outlet facing the windows. It has all the economical advantages that come from installing and operating a central heated and chilled water production unit. The location facilitates hydraulic connection via the suspended ceiling of the adjoining corridor, and gravity draining of condensate (no pump).

The 42KY cassette must be suspended from the ceiling with four 6 mm or 8 mm threaded rods (not supplied), that are fixed to the four mounting brackets of the device with elastic anti-vibration mounts or a nut/washer assembly fitted either side of the mounting bracket.

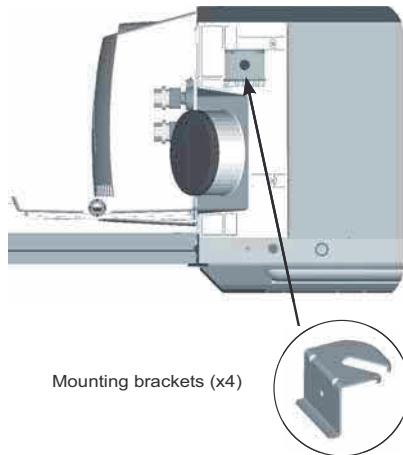

Mounting brackets (x4)



Mounting principle
2 methods

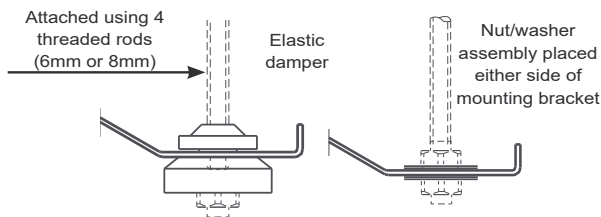

Diffuser mounting system with 4 captive screws

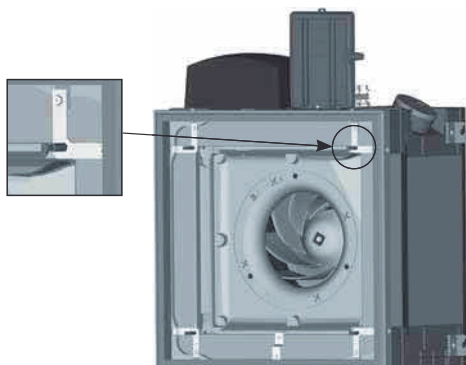

Operating principle

The centrifugal turbine draws air through a perforated metal intake grille. The air is filtered, then heated or cooled through a temperature exchange coil fed with either hot or chilled water. The air is then pulsed horizontally at 180° or 360°, by means of the Coanda Effect in the room to be treated.

The Coanda effect

Coanda effect diffuser:

The single slot peripheral outlet with its narrow opening and specific internal profile will increase the initial speed of the air as it leaves the diffuser. The high speed of the moving flow of air causes an area of low pressure which keeps it close to the ceiling, (there is no direct blast on occupants) and the ambient air is drawn in by induction to be reinjected in the air stream. The air mix rate, the range and the coverage of the air flow are improved, which reduces thermal phenomena that cause discomfort in the occupied area (residual air flow rate, asymmetric temperatures, radiation caused by walls, etc.).

"Anti cold shower" system

The one-way 180° diffuser is fitted with an "anti cold shower" system that maximises comfort by preventing cold air from falling between two cassettes.

The system incorporates two deflectors in the insulation which offsets the air stream slightly in the lateral axis. When the units are placed side by side in the same room, the air flows do not oppose one another and cross over in parallel, which avoids any cold air draughts.

This patented system removes the discomfort caused by draughts without having to reduce the outlets and with no increased noise levels, while maintaining the air flow necessary for the thermal requirements.

with anti "cold shower" system



without anti "cold shower" system



OPERATION AND ADVANTAGES

Fresh air inlet spigot

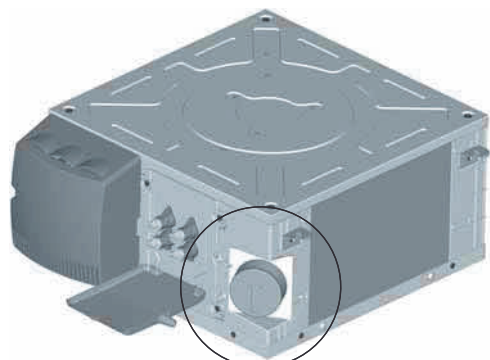

Ø 100 mm spigot, max. air flow 90 m³/h recommended. Network balancing system not supplied by Carrier.

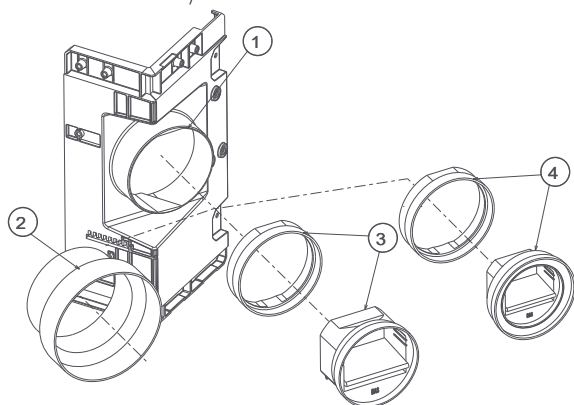

- 1) Fresh air inlet on device
- 2) Ø100 / Ø125 mm adapter
- 3) 60/75/90 m³/h air flow controller kit
- 4) 15/30/45 m³/h air flow controller kit

Innovative design

- Next generation chassis that combines high density EPS for its thermal and phonic properties, ABS PC and a ribbed galvanised sheet steel base to stiffen the assembly.
- Chassis with unique dimensions for all sizes, adapted to the suspended ceiling grid size 600 x 600 mm.
- Hydraulic, air and electrical connections on the same side to facilitate installation and access for maintenance operations.
- Fresh air inlet with 100 mm sleeve integrated to the chassis with removable plug.

Range

The 42KY one-way cassette range includes 3 models that cover a flow rate of 250 to 770 m³/h which meet the most stringent of sound level requirements.

The 42KY is available as:

- 2-tube system, with heating or cooling mode.
- 2-tube + 2-wire system, with heating + cooling/cooling + electric mode.
- 4-tube system, with heating and cooling mode.

Advantages

- The use of a heat transfer fluid is an ecological and durable solution.
- Individual adjustment of the indoor temperature.
- Responsive system.
- Large power range.
- Coanda effect diffusion over 180 or 360° for even coverage and perfect control of the thermal phenomena that can cause discomfort.
- Acoustic comfort.
- LEC low consumption motor.
- G3 filter.
- Optimised hydraulic coil.
- Condensate drain by gravity avoiding the need for a drain pump.
- Modern and elegant design for perfect integration.
- Environmentally responsible product.
- Ease of maintenance.

Greater comfort

Optimised Coanda Effect diffusion for perfect control of thermal phenomena that can cause discomfort and make the room feel draughty.

Compliance with energy requirements

- Specially developed temperature exchange coils to meet the requirements of low energy buildings.
- Optimised temperature exchange coils to limit cost and consumption in comparison with the other components of the installation.
- LEC low consumption motor.
- Reduction in power of the electric heating coils to match the requirements of new buildings.

Eco-design

Raw materials

30% saving in weight and 21% saving in volume thanks to a compact and well thought out architecture.

Use of easily recyclable materials (EPS and ABS).

Transport

Raw material suppliers selected from those that are less than 100 km from our manufacturing and packaging factory, enabling a 50% gain in volumes transported (reduction in CO₂ emissions).

Recycling and ease of disassembly

90% recyclable products.

Materials can be completely separated and fixings have been reduced by 40% to allow

greater efficiency at recycling plants.



OPERATION AND ADVANTAGES

Ease of installation and operation

- The 42KY cassette is designed to be easy to fit and not require many on-site operations:
- Fitting template provided with each unit to mark out the anchoring points on the ceiling.
- Optimised weight and size to facilitate handling during installation.
- Mounting brackets equipped with anti-slip system to hold the threaded rods when attaching and levelling the unit.
- Safety system to suspend the diffuser leaving the technician's hands free to tighten the mounting bolts.

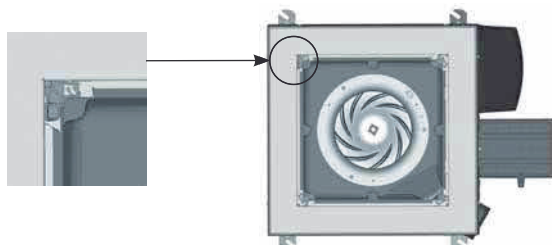

- Technical plate containing all connections (electrical, air and hydraulic) on one face.
- Fresh air inlet sleeve with plug integrated directly to the chassis (no fitting necessary).
- Large electrical box with single latch that can house all the control systems of the CARRIER range.
- Access to internal components without the need to open suspended ceilings, easy to open filter hatch grille that is hinged to facilitate maintenance operations.
- Diffusion panels supplied in individual packaging, making it easier to fit the unit with no risk of damaging or soiling visible parts during installation.

CODES

Product ref.	Range				Size	Motor	Coils	Control	Valves	Elec heater	Valve servomotors	Sensors	Condensate drainage	Grille adaptation	Coil protection	Modif. index
	4	2	K	Y	1	9	C	-	G	A	-	A	P	T	-	A
Digit	1	2	3	4	5	6	7	8	9	10	11	12	13	14	15	16

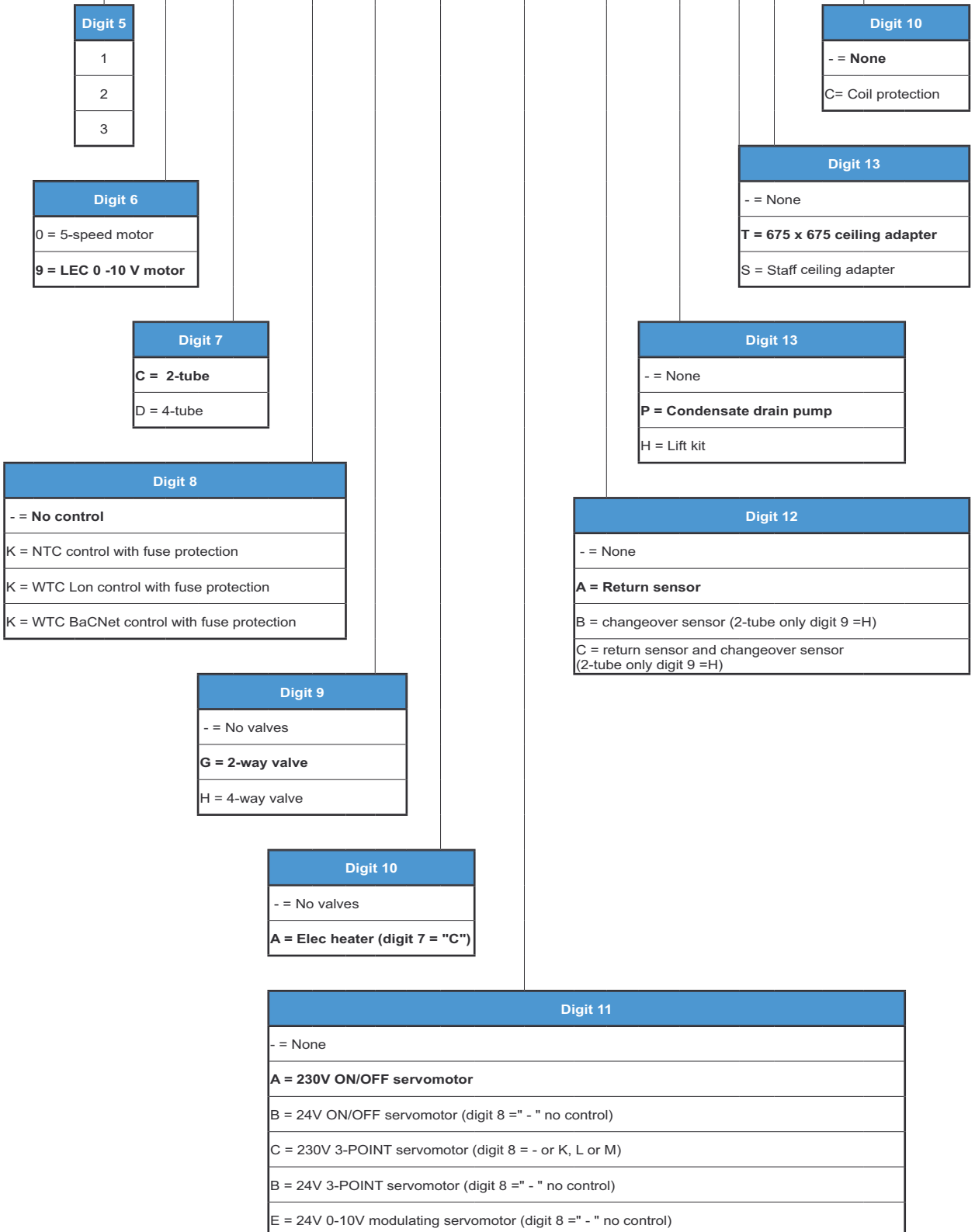

TECHNICAL DESCRIPTION

Return/supply interface

Coanda Effect diffusion through a single slot with a narrow opening and specific internal profile.

- 180° diffusion (1-way) or 360°C diffusion (4-way)
- In sheet metal painted in RAL 9010 to be fitted over the chassis with exactly the same dimensions as a standard suspended ceiling tile.
- Perforated metal return grille with hinge-mounted filter housing that requires no tools to open it.
- PSE insulation, M1 fire resistance with very low heat transfer coefficient.
- Flat G3 filter on metal frame.

Chassis

- Unique chassis and reduced footprint for all sizes fitted in place of a suspended ceiling tile, either 600 x 600 mm or 675 x 675 mm (optional).
- Ribbed galvanised steel motor support base panel, 10/10th thick.
- High-density PSE casing integrating thermal and acoustic functionalities. 15 mm thick base and 25 to 30 mm thick vertical sides that make up the casing.
- Low emission of TVOCs and no halogenated compounds.
- ABS corner reinforcements fitted with open galvanised steel mounting brackets with one-way system for assembly of threaded rods.
- M1 fire rating.
- Hydraulic, air and electrical connections on the same side of the technical panel at the rear of the unit providing a single access point.
- Galvanised 0.8 mm sheet metal frame finished in RAL 9010 to which the diffusion interface is fixed.

Water coil

- 1 hot water or cold water circuit (2-tube system).
- 1 hot water circuit + 1 cold water circuit (4-tube system).
- One-piece coupling with 40 mm center to center distance with integrated sealed flush fitting female revolving unions and gaskets, for easy fitting of the control valves.
- One, two or three row circular coil with low pressure drop.
- Copper tubes, one-piece aluminium fins (1.6 mm pitch).
- Bleeding and draining.
- Rated pressure of 16 bar (at 20°C).
- Test pressure: 24 bar.
- Max hot water inlet temperature:
 - 4-tube application: 80°C,
 - 2-tube application: 70°C,
 - 2-tube/2-wire application: 55°C (min air flow rate: 200m³/h).
- Min cold water inlet temperature: 6°C.

Electric heater (2-tube + electric system)

- 230V/1/50 single-tube electrical elements inserted into the aluminium housing.
- 2 temperature limiters, manually and automatically reset, inserted in the aluminium block with easy access that does not require the suspended ceiling to be opened, via the return/supply air interface.
- Heater element power supply on the connection terminal inside the electrics box.
- Option to deactivate a heater element on site by means of a shunt on the terminal to reduce the electrical power.
- Condensate drain pan
- Single-piece all-climate primary pan in high density watertight EPS, naturally tilted and can be removed from underneath with no need to open the suspended ceiling.
- M1 fire rating class.
- PC ABS auxiliary pan (configured to prevent standing water) to be used to catch condensate from valves from the primary pan.
- Gravity drain: height 70mm.
- Drainage bushing: external Ø 15 to 20 mm.

Fan motor assembly

LEC motor (low energy consumption)

Low energy motor making it possible to reduce electrical consumption by up to 85%.

- Sealed, tropicalised, with protected shaft.
- Progressive control with 0-10V control signal.
- Internal automatic heat protection with serial opening on winding.
- Mounted on rubber mounts.
- 230V/1Ph/50 Hz power supply (60Hz compatible).

Note: The minimum voltage to start up the motor is 2V.

Or

Asynchronous motor

5 factory-wired speeds connected to a terminal strip for customisation.

- Sealed, tropicalised, with protected shaft.
- Permanent capacitor.
- Ball bearings.
- Internal automatic heat protection with serial opening on winding.
- Resilient mounts.
- 230V/1Ph/50 Hz power supply (60Hz compatible).
- High efficiency and power factor.

Fan(s)

- Balanced centrifugal impeller (Ø 282 mm) with airfoil blades.
- Polymer impeller.
- Single-point mounting system with foolproofing device.

TECHNICAL DESCRIPTION

Electrics box

- Large ABS electrics box, with a hinge to keep it open and screw closure.
- Protection rating IP20.
- Terminal block on DIN rail in accordance with EN 50022, depth 7.5 mm.
- Junction block located with tension clamp. Cross section 0.5 to 2.5 mm² - Max current: 24A – Shock resistance: 8 kV. Cable routing for customer connections.

Fresh air inlet sleeve

Connecting sleeve for fresh air inlet, Ø100 mm, integrated to the chassis with removable plug.

Filtration

- Regenerative flexible polyester fibre filter element.
- Positioned at the fan inlet.
- EN779 efficiency Class: G3.
- On rigid metal frame.
- Accessed via the hinged inlet grille.
- Low energy impact.
- M1 fire rating.
- A protected air stream which prevents particles being drawn into suspended ceilings.
- Uniform treatment of the room thanks to optimised diffusion using the Coanda effect.
- Suitable mixing rate.

Device mounting

- Open mounting brackets, factory-fitted, made from galvanised steel, 15/10th thick, with check valve for securing the threaded rods during fitting and levelling.

Packaging

- Strapped cardboard crate for the casing.
- Fitting template and direction of fitting printed on the cardboard.
- Return/supply air interface supplied separately in protective cardboard packaging.
- Delivered on a plastic-wrapped pallet.

Control systems

- A-B-C-D type electronic thermostats.
- NTC / Aquasmart Evolution networked electronic control.
- WTC LON or BACnet networked electronic control.

Options (factory assembled)

- Condensate drain pump.
- Lift kit.
- Finishing trim frame for 675 x 675 mm suspended ceiling tiles.
- Finishing trim frame for STAFF ceilings.
- Hydraulic coil with protected fins for aggressive / corrosive areas (locations close to the sea or to chemical industries).

Accessories (available separately)

- Vibration damping rubber mounts for mounting brackets.
- Self-regulating conditioned fresh air inlet module (3 flow rates adjustable using a set of shims).
- Ø 100-125 mm sleeve adapter.
- Condensate drain pump kit with high safety device.
- 80 mm riser kit for gravity drainage without condensate drain pump.
- Finish counter frame kit for 675 mm suspended ceiling tile.

INTEGRATION INTO THE SUSPENDED CEILING

Mounting position with 600 x 600 mm suspended ceiling on T-shaped profile

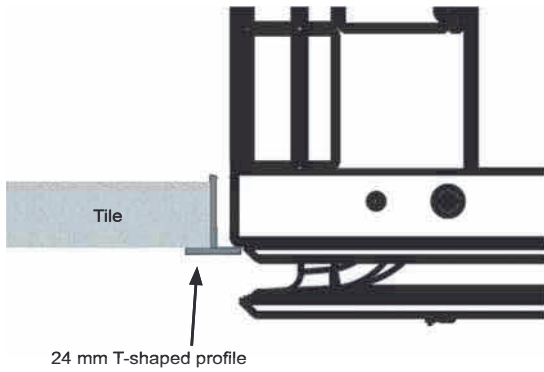

Mounting position with 600 x 600 mm suspended ceiling on T-shaped profile with 8 mm shadowgap

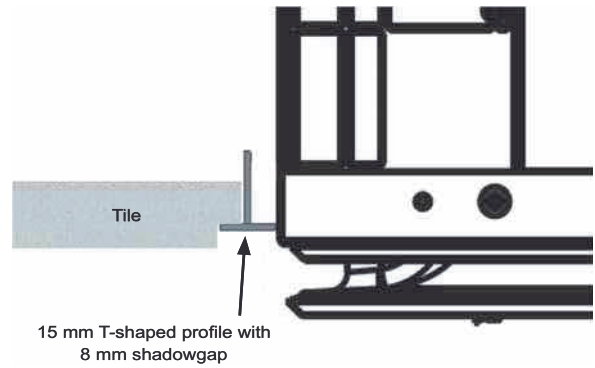

DIMENSIONS

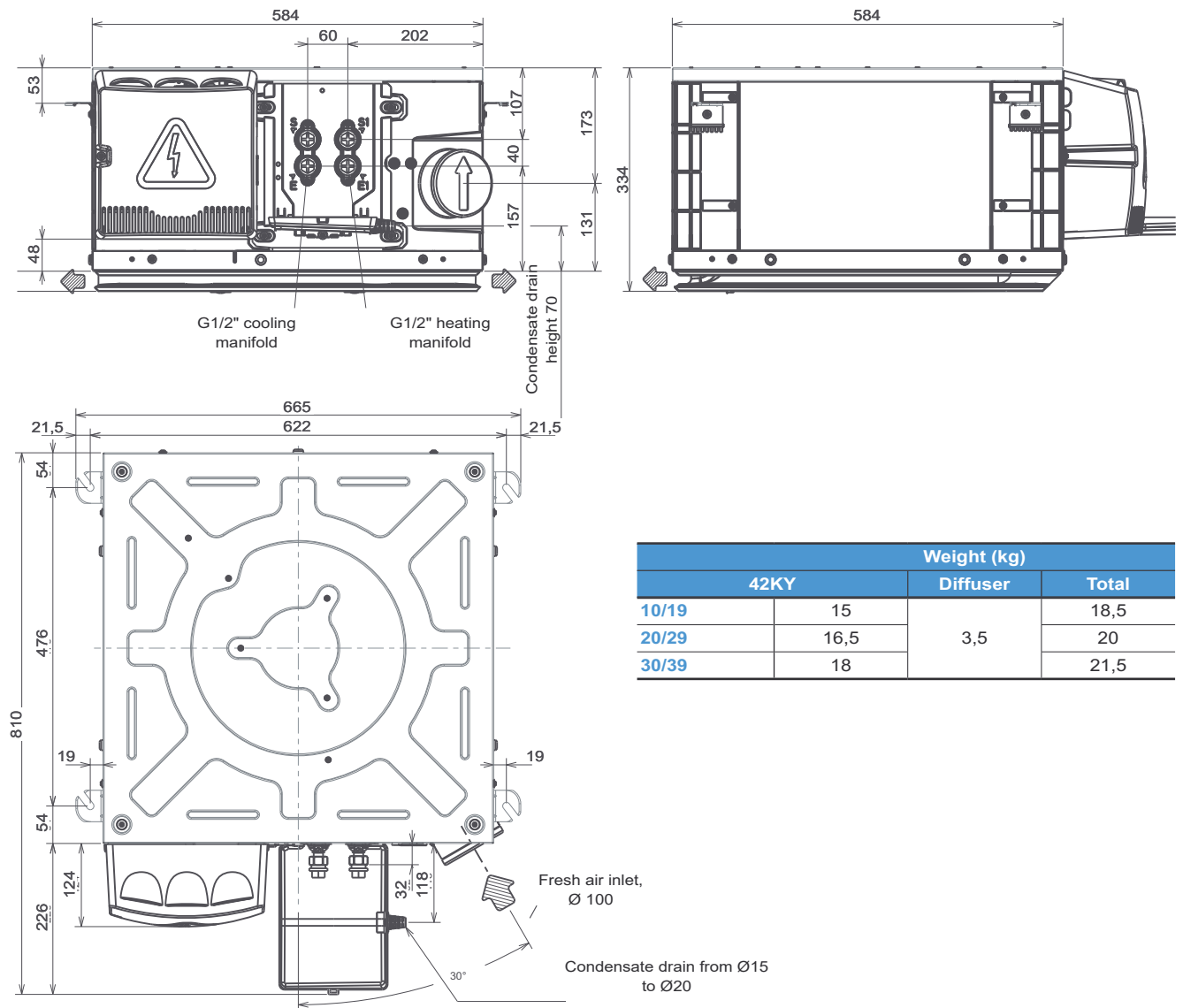

Weight (kg)			
	42KY	Diffuser	Total
10/19	15	3,5	18,5
20/29	16,5		20
30/39	18		21,5

SPECIFICATIONS FOR UNITS UNDER EUROVENT CONDITIONS

2 pipes application

Model	Speed	Voltage	Input Power	Air flow	Heating capacity	Pressure drop	Cooling capacity		Lw	LP	Comfort level (ISO or NR)	Average air temperature rise in K Auxiliary electric heater 230/1/50	
							Total W	Sensible W					
		v	W	m³/h	W	kPa			dB(A)	dB(A)			
42KY10C-----	HS		45	440	2 000	1 700	1 550	49	49	37	32		
	MS		41	380	1 800	1 530	1 390	46	46	34	29		
	LS		34	235	1 350	1 190	1 030	37	37	25	19		
42KY19C-----	HS	4,9	17	440	2 070	1 700	1 550	49	49	37	32		
	MS	3,4	8	310	1 650	1 370	1 220	46	42	34	29		
	LS	2,5	5	235	1 400	1 190	1 040	37	37	25	19		
42KY20C-----	HS		45	420	2 700	2 600	2 030	51	51	39	34		
	MS		41	360	2 300	2 280	1 750	47	47	35	30		
	LS		34	215	1 550	1 580	1 150	35	35	23	18		
42KY29C-----	HS	4,9	17	420	2 700	2 590	2 020	51	51	39	34		
	MS	4,2	12	360	2 300	2 280	1 760	47	47	35	30		
	LS	2,5	5	215	1 550	1 580	1 150	35	35	23	18		
42KY20C--A----	HS		45	420	2 390	2 050	1 800	51	51	39	34	900W (2R)	6,4
	MS		41	360	2 200	1 870	1 580	47	47	35	30		7,4
	LS		34	215	1 600	1 420	1 090	35	35	23	18		12,4
42KY29C--A----	HS	4,9	17	420	2 390	2 040	1 790	51	51	39	34	900W (2R)	6,4
	MS	4,2	12	360	2 200	1 870	1 590	47	47	35	30		7,4
	LS	2,5	5	215	1 600	1 420	1 090	35	35	23	18		12,4
42KY30C-----	HS		77	660	4 150	4 340	3 260	58	51	46	40		
	MS		56	525	3 350	3 540	2 620	51	47	39	34		
	LS		40	405	2 600	2 840	2 070	45	35	33	27		
42KY39C-----	HS	6,7	38	660	4 150	4 350	3 270	58	51	46	40		
	MS	5,3	21	525	3 350	3 540	2 630	51	47	39	34		
	LS	3	6	290	1 900	2 210	1 570	38	35	26	19		
42KY30C--A----	HS		77	660	4 050	3 833	3 009	58	58	46	40	1200W (2R)	5,4
	MS		56	525	3 300	3 169	2 442	51	51	39	34		6,8
	LS		40	405	2 720	2 600	1 955	45	45	33	27		8,8
42KY39C--A----	HS	5,3	21	525	3 320	2 260	2 890	51	58	39	34	1200W (2R)	6,8
	MS	4,6	15	460	2 950	2 610	2 010	48	51	36	30		7,7
	LS	3	6	290	2 110	1 910	1 400	38	40	26	19		12,3

4-tube

Model	Speed	Voltage	Input Power	Air flow	Heating capacity	Pressure drop	Cooling capacity		Lw	LP	Comfort level (ISO or NR)
							Total W	Sensible W			
		v	W	m³/h	W	kPa			dB(A)	dB(A)	
42KY20D-----	HS		45	420	2 400	2 050	1 800	51	39	34	32
	MS		41	360	2 200	1 870	1 580	47	35	30	29
	LS		34	215	1 700	1 420	1 090	35	23	18	19
42KY29D-----	HS	4,9	17	420	2 400	2 040	1 790	51	39	34	40
	MS	4,2	12	360	2 200	1 870	1 590	47	35	30	34
	LS	2,5	5	215	1 700	1 420	1 090	35	23	18	19
42KY30D-----	HS		77	660	3 000	3 833	3 009	58	46	40	40
	MS		56	525	2 600	3 169	2 442	51	39	34	34
	LS		40	405	2 200	2 600	1 955	45	33	27	27
42KY39D-----	HS	5,3	21	525	2 600	2 260	2 890	51	39	34	34
	MS	4,6	15	460	2 400	2 610	2 010	48	36	30	30
	LS	3	6	290	1 900	1 910	1 400	38	26	19	19

EUROVENT Conditions

- Cooling mode: water temperature: 7/12°C, inlet air temperature: 27°C - 19°C (WB)
- Heating mode (2T): water temperature: 45°/40°C, inlet air temperature: 20°C
- Heating mode (4T): water temperature: 65°/55°C, inlet air temperature: 20°C
- The sound pressure levels (Lp) and ISO NR level are based on hypothetical attenuation of the room of 12 dB(A)

TECHNICAL SPECIFICATIONS

Coil capacity (L)

42KY cassette		10/19	20/29	30/39
2-tube coil		0.4	0.8	1.1
2-tube coil + electric heater		-	0.6	1
4-tube coil	Cooling	-	0.6	1
	Heating	-	0.2	0.2

Diameters of coil couplings

Coil connection type: flush fit female threaded union nuts

Valve connection type: install flush fit male threaded unions

42KY cassette		10/19	20/29	30/39
2-tube coil		G 1/2"	G 1/2"	G 1/2"
2-tube coil + electric heater		-	G 1/2"	G 1/2"
4-tube coil	Cooling	-	G 1/2"	G 1/2"
	Heating	-	G 1/2"	G 1/2"

Motor electrical specifications

42KY	Motor information	AC asynchronous motor			LEC motor		
		10	20	30	19	29	39
Input power (W)	V5	70	70	101	38	38	56
	V4	45	45	77	17	17	38
	V3	41	41	56	12	12	21
	V2	38	38	47	8	8	15
	V1	34	34	40	5	5	11
Input current (A)	V5	0,30	0,30	0,32	0,18	0,18	0,40
	V4	0,21	0,21	0,29	0,09	0,09	0,28
	V3	0,19	0,19	0,24	0,07	0,07	0,17
	V2	0,18	0,18	0,22	0,04	0,04	0,13
	V1	0,17	0,17	0,21	0,02	0,02	0,10

NB: Specifications given for a 230 V +/-10% - 50 Hz power supply.

- For operation at 60Hz, the power input and rotation speed values are generally higher.

- Motor operating range: min. return T°C: 0°C, max. return T°C: 40°C Unit information plate

The information plate shows all the information needed to identify the unit and its configuration. This plate is placed on the technical side that has all the connections, above the fresh air inlet.

- ① Code
- ② Serial number
- ③ Description of the unit
- ④ Rated motor power
- ⑤ Motor rotation speed
- ⑥ Coil type
- ⑦ Wiring diagram reference
- ⑧ Motor speed wiring
- ⑨ Maximum operating pressure
- ⑩ Electric heater specifications (if fitted)

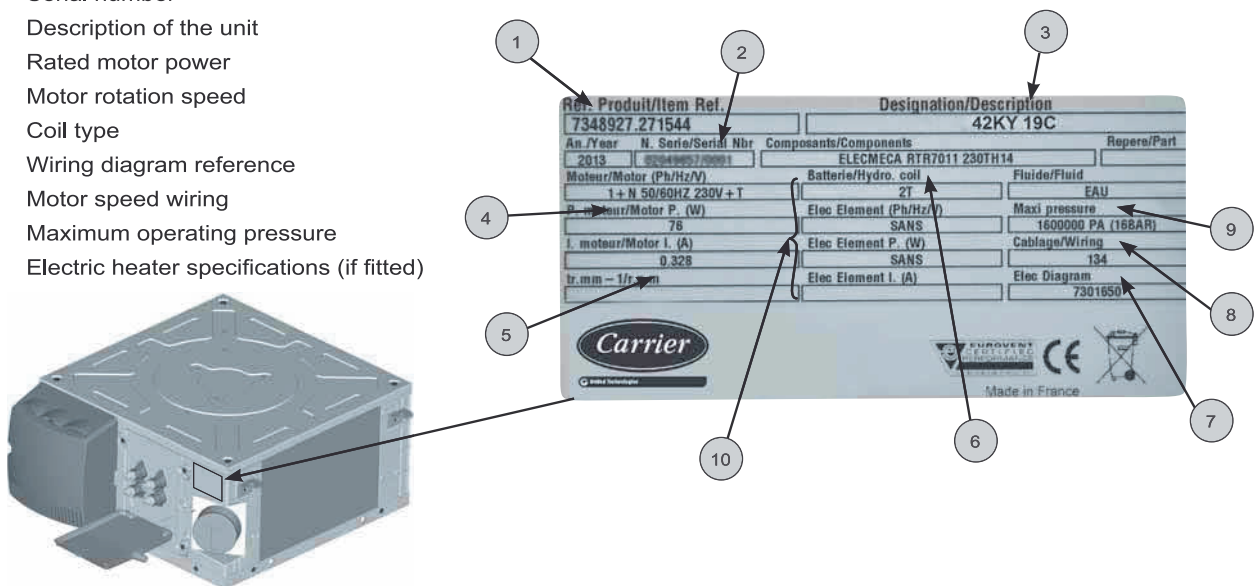

AIR TREATMENT

TECHNICAL SPECIFICATIONS

Electrical heaters

2 single-tube 230/1/50 electrical elements inserted into the aluminium housing and bent around the hydraulic coil.

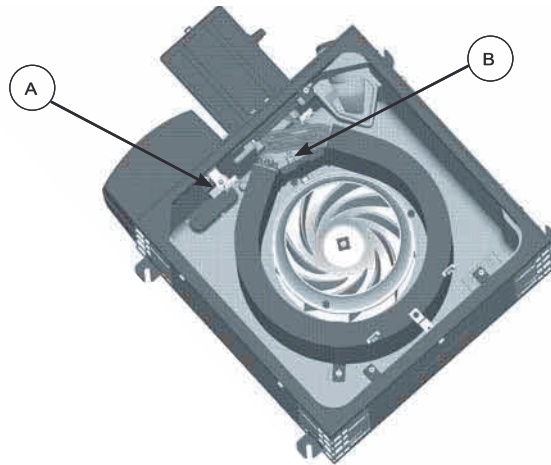

Remove shunt to deactivate a heater (reduction of 300w)

- (A) Temperature limiter with manual reset
- (B) Temperature limiter with automatic reset

Electrical heater specifications - Input voltage 230V - 1 ph - 50Hz

42KY cassette	10/19	20/29	30/39
Electrical power (W)	-	900	1200
Input current (A)	-	3.6	4.8

Limitations of use

42KY cassette	Operating pressure max. 16 Bar	Minimum water inlet temperature: 6°C
		Maximum water inlet temperature:
		4-tube coil: 80°C
		2-tube coil: 70°C
Indoor temperature	-	Minimum temperature: 5°C
	-	Maximum temperature: 40°C
Power supply	Nominal usage limitations	Min 207 - Max 253 V for units without electrical heater
		Min 216 - Max 244 V for units with electrical heater

OPTIONS (FACTORY ASSEMBLED)

Condensate drain pump

The pump discharge must be connected to the wastewater pipe by a flexible tube with an internal diameter of 6 mm (not supplied).

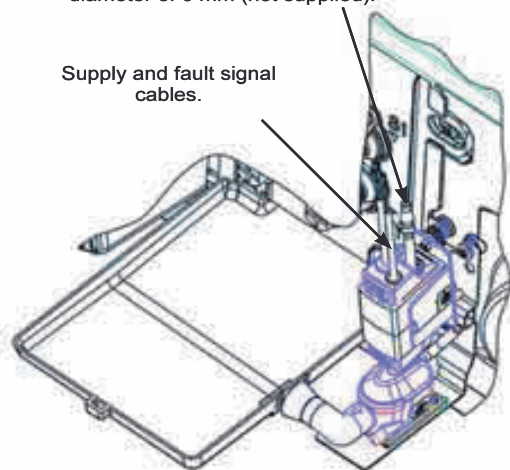

Maximum flow rate	10.4 l/h
Maximum discharge height	7 m (flow rate 4 l/h)
Maximum pressure	10 m (flow rate 0 l/h)
Sound level at 1 m in accordance with EN ISO 3744 and 4871 (measurements taken at LNE, pump in water, outside of application)	20.2 dBA
Power supply	230V +10%/-15% - 50/60Hz - 19W
Electric insulation class	Class 1
Detection levels	ON: 14.7 mm, OFF: 10.7 mm, AL: 17 mm
Safety switch	NF: 5A resistance - 250V AgNI 90/10 gold-plated contacts.
Thermal protection (overheating)	70°C (automatic restart)
Operating cycle (operating factor)	100%
Protection (as per NF EN 60529)	IP64
Safety standard	CE
RoHS directive	Compliant
WEEE directive	Compliant

Pump performance Water flow in litres per hour (-15% / +20%)				
Discharge height	Horizontal length of the discharge pipe			
	5 metres	10 metres	20 metres	30 metres
1 metre	10.4	9.1	8.3	7.3
2 metres	8.5	7.8	7	6.4
3 metres	7.9	7.1	6.3	5.8
4 metres	7	6	5.3	4.9

Operating limit:

Drain: flexible tube int. Ø 6 mm, end piece Ø 8.8 mm. This accessory must be paired with a valve control to allow the upper safety limit to control the valve's closure (stopping condensate).

$$\text{Condensate flow rate (l/h)} = \frac{\text{Total capacity} - \text{Sensible capacity (W)}}{680}$$

Accessories (available separately)

Description	
Condensate drain pump kit	
Elastic dampers (4 per device)	
Lift kit	
Self adjusting module kit, diameter 100 mm	15/30/45 m ³ /h
	60/75/90 m ³ /h
AN adapter kit, diameter 100/125 mm	
Frame kit for suspended ceiling 675x675	
LEC motor speed control 3 speed ON/OFF unit kit (only for thermostat or controllers not from CARRIER that have 3 x 230V speed outputs)	
Description	
Condensate drain pump	
Lift kit	
Frame for 675 x 675 suspended ceiling tiles	
Finishing trim frame for STAFF ceilings	
Hydraulic coil with protected blades	