

NEW

PACKAGED ROOFTOP HEAT PUMPS AND SEPARATED GAS MODULE OPTION



High efficiency
Superior reliability
Compact system
Energy recovery
Variable speed EC fans

50FF/FC

Cooling capacity 22-90 kW
Heating capacity 21-89 kW

The new 50FC packaged rooftop range consists of autonomous compact air-air units of horizontal design, rooftop type, for **reversible heat pump** operation.

The range of available capacities in the series allows for the air conditioning of medium and large surface areas which are common in shopping malls, food retail, logistics and many other commercial and industrial applications.

50FC units are designed for optimized part-load management in achieving the highest levels of seasonal efficiency, exceeding the limits set by regulation.

With its mono-block lightweight construction, the units feature a self-supporting frame, designed to ease the installation and maintenance works.

The units integrate the latest technological innovations:

- Multi-scroll compressors.
- Electronic expansion valves.
- Variable speed EC fans.
- Auto-adaptative microprocessor control.

For maximum adaptability, a number of options is available to meet any operating requirement:

- Exhaust air energy recovery.
- Economizer.
- Indoor air quality management.
- Installation roofcurbs.
- Auxiliary heating modules.
- Extended operation limits.



CARRIER participates in the ECP programme for RT
Check ongoing validity of certificate:
www.eurovent-certification.com

FEATURES AND ADVANTAGES

Carrier's new range of packaged rooftop air conditioning units 50FC has been designed to set high standards in performance. The series offers design flexibility, ease of installation, quality and superior reliability thanks to the number of technological improvements and the available options that allow for seamless integration in the building.

Designed to withstand outdoors installation, it can operate all-year-round performing at the highest levels of seasonal efficiency thanks to the management of the new control inside.

The high efficiency cooling circuits have been developed as to eliminate any leaks caused by any vibration modes and designed with state-of-the-art components including electronic expansion valves in all the circuits. The refrigerant circuits come fitted with pressure transducers and temperature sensors which allow for accurate control on the operation conditions together with the management of the fans speed.

The cabinet has been designed and tested for the most demanding conditions. With double skin insulated side panels as standard, all the sheet metal work comes in powder-coated finishes outdoors and indoors. The self-supporting structure has been conceived also to reduce weight and to optimize transportation capabilities. Thorough transportation tests have been also conducted as to validate the two-height stackable feature.

Ease of maintenance is also granted thanks to the great accessibility to components through removable side panels, access doors fitted with dual hinges with locking functions or removable outdoor fans covers. The condensates drain pan is now removable for easy cleansing.

Additional energy savings are possible thanks to multiple options such as economizers, exhaust air energy recovery or indoor air quality sensors. This can also be combined with scheduling functions or BMS integration through many standardized protocols.



Design flexibility

All 50FC units are field-convertible to horizontal air flow. Being able to convert a unit from vertical airflow to horizontal makes it easy to overcome job site complications.

- Vertical supply/return units are ideal for new construction or retrofit to existing installations. The low unit profile is maintained when the unit is installed on the accessory roofcurb.

The ducts can be attached directly to the roofcurb to allow all ductwork to be completed before the unit is positioned.

- Horizontal units are ideal for replacement or applications such as through-the-wall where sound must be attenuated before the duct penetrates the roof. Ducts connect directly to the unit. Horizontal units may be curb or slab mounted.

Easy and fast installation

The unit is connected directly to an air distribution ductwork without additional elements or equipment, pipes, cables, etc. taking no floor space at all. This design reduces the cost of installation, facilitates a quick connection and ensures reliable operation.

A vast number of options integrated in the unit meet many operating requirements.

Superior reliability

- Excellent full and part load efficiencies are achieved by using tandem scroll compressors. The compressors are equipped with crankcase heaters and protected by electronic sensors and logic to control minimum on and off times and reverse rotation.
- All units are tested at various stages on the production line for circuit leakage, electrical compliance and refrigerant pressures.

Advanced technology and performance

In tertiary sector installation, a high percentage of the annual air conditioning energy consumption comes from the use of fans for transporting air. Using fans which are more efficient has a direct impact on reducing consumption.

- Electronic plug-fans in the indoor circuit with direct drive and variable speed offer the following advantages:
 - Elimination of friction losses during transmission thanks to the direct drive.
 - Greater aerodynamic efficiency of the rotor (reactive blades with an optimized profile), running at very high operating pressures.
 - Greatly increased motor efficiency. Permanent magnets DC motors activated using electronic switching integrated into the motor itself.
 - Variable speed to ensure a constant supply air flow rate, independent of the filters clogging level.
 - Measuring the flow rate through a calibrated section at the fan intake and a differential pressure sensor allows the control to handle the flow rate reliably and precisely in both on CAV and VAV systems.
- Electronic axial fans in the outdoor circuit which adapt the rotation speed to the installation's requirements, reducing electricity consumption, the sound level at part load and improving the unit's average seasonal efficiency.

Environmental care

- Making an environmentally responsible decision is possible when using R-410A refrigerant.

This refrigerant is an HFC refrigerant that does not contain chlorine that is damaging to the ozone layer, and unaffected by the Montreal Protocol. R-410A refrigerant is a safe, non-toxic, efficient and environmentally balanced for the future.

- Also, to reduce the environmental impact, this new series is not requiring any wooden pallets for handling, thus eliminating not only the waste disposal but avoiding the cut of trees.

KEY FOR CONFIGURATION

A	B	C	D	E	F	G	H	I	J	K	L	M	N	O	P	Q	R	S	T	U	V	W
50FC	020	A	4	A	B1	LL	000	S	N	A	H	S	000	0000	0000	0	0	AA00	00	A00	000	AA00

A: Unit type

50FC: air/air heat pump

B: Unit model

1 circuit: 020 / 028 / 037 / 040 / 045 / 047
2 circuits: 052 / 058 / 062 / 070 / 074 / 086 / 093

C: Version of the series

A: Current version

D: Electrical power

4: 400V / 3ph + N / 50Hz
5: 400V / 3ph / 50Hz

E: Type of refrigerant

A: R410A

F: Flow + Assembly

B1: Standard.
B2: Standard. Economizer, 2 dampers
B3: Standard. Economizer, 3 dampers
BX: Standard. Axial fan in return section
BP: Standard. EC plug-fan in return section
BA: Standard. Cooling recovery circuit with EC plug-fan in return section
BT: Standard. Return top box with EC plug-fan
BB: Standard. Cooling recovery circuit with EC plug-fan in return top box
BW: Standard. Heat recovery wheel module
R1: In-line.
R2: In-line. Economizer, 2 dampers
RP: In-line. EC plug-fan in return section
RW: In-line. Heat recovery wheel module

G: Coil coating : Outdoor - Indoor

LL – Outdoor coil	-	Indoor coil
L: Aluminium	L: Aluminium	
P: Polyurethane	P: Polyurethane	
N: Inera®	N: Inera®	
C: Copper	C: Copper	
Y: Blygold®	Y: Blygold®	

H: Heating

000: Without auxiliary heating
BAx: Gas burner, 3 power outputs:
x = F (Low) / M (Nominal) / S (High)
BBx: Boiler with hot water coil, 3 power outputs:
x = F (Low) / M (Nominal) / S (High)
RAX: Electrical heaters, 3 power outputs:
x = F (Low) / M (Nominal) / S (High)
HAX: Hot water coil, 2 options:
x = S(Standard) / F(Very low outdoor T)

I: Protection for low outdoor temperature

S: Without protection
A: Freeze protection OAT lower than -10°C
B: Freeze protection OAT lower than -14°C
C: Freeze protection OAT lower than -10°C + spring shut-off dampers
D: Freeze protection OAT lower than -14°C + spring shut-off dampers

J: Supply fan

N: 3 available pressures
F (Low) / N (Nominal) / S (High)

K: Air filtration + droplet eliminator

A: G4
B: G4+ droplet eliminator
C: G4 low pressure drop
D: G4 low pressure drop + droplet eliminator
E: G4 + M6
F: G4 + M6 + droplet eliminator
G: G4 + F7
H: G4 + F7 + droplet eliminator
I: G4 + F9
J: G4 + F9 + droplet eliminator
K: G4 l.p.d. + F7
L: G4 l.p.d. + F7 + droplet eliminator
M: G4 l.p.d. + F9
N: G4 l.p.d. + F9 + droplet eliminator
O: M6 + F7
P: M6 + F7 + droplet eliminator
Q: M6 + F9
R: M6 + F9 + droplet eliminator
S: F7 + F9
T: F7 + F9 + droplet eliminator
U: F9 + F9
V: F9 + F9 + droplet eliminator

L: Outdoor fan

L: AC (2-speed)
H: EC (electronic)

M: Insulation

S: Standard insulation
M: Euroclass A2-s1, d0 (M0) insulation

N: Indoor unit

000 – Without optional accessories
A: Condensate drain pan in stainless steel
A: Room overpressure management
A: Filter fouling detector

O: Outdoor unit

0000 - Without optional accessories
A: Unused
A: Outdoor coil protection grid
A: Antivibration mounts
A: Droplet eliminator at the fresh air intake

P: Heat recovery wheel

0000 - Without optional accessories
A: Filters G4
B: Filters G4 low pressure drop
C: Filters G4 + M6
A: Wheel speed with on/off control
B: Wheel speed with variable control
A: Channel spacing of 2,0 mm
B: Channel spacing of 2,5 mm
A: Material: Aluminium
B: Material: Aluminium with epoxy
C: Material: Hybrid wheel
D: Material: aluminium with silicagel

Q: Unused

R: Unused

S: Sensors

0000 - Without options
A: Smoke detection control unit
A: CO₂ sensor environment installation
B: CO₂ sensor ducted installation
C: CO₂ sensor on the pLAN network
A: 1 sensor RS485
B: 2 sensors RS485
C: 3 sensors RS485
D: 4 sensors RS485
E: 1 sensor NTC
A: Ambient temperature sensor
B: Dual ambient temp.+humidity sensor
C: Ambient sensor on the pLAN network

T: Economizer management + Outdoor hum.

00 – Without economizer + without sensor
A: Outdoor humidity sensor on the unit
B: Outdoor humidity sensor on pLAN network
A: Thermal management
B: Thermoenthalpic management
C: Enthalpic management

U: Terminal + Unit communication

000 – Without terminal + stand-alone unit + without card
A: Communication card RS485 Modbus/Carel
B: Communication card Ethernet PCoWeb
C: Communication card RS485 LonWorks®
D: Communication card Ethernet BACnet™
E: Communication card RS485 BACnet™
F: Communication card RS485 Konnex
0: Stand-alone unit
A: Master unit
B: Slave unit
A: Graphic terminal in the electrical cabinet
B: User terminal in the electrical cabinet
C: Graphic terminal in the cabinet + user terminal remote up to 100 m
D: User terminal in the cabinet + Graphic terminal remote up to 200 m
E: Graphic terminal in the cabinet + Graphic terminal remote up to 200 m

V: Miscellaneous item 1

000 – Without options
A: Management of an humidifier with on-off control
B: Management of an humidifier with proportional control
A: Electrical energy meter
B: Cooling capacity and electrical energy meter
A: Unused

W: Miscellaneous item 2

AA00 - Switching devices + std phase relay
A: Compressor soft starter
A: Varnish protection
B: High performance phase sequence relay
B: High grade switching devices

UNIT COMPONENTS

Casing

- Casing made of galvanised steel metal with polyester paint, white colour RAL 7035.
- New self-supporting frame that allow the transport of two stacked units and without the need for a wooden pallet.
- Removable panels for easy access to all components: electrical cabinet, compressors, fans, filters, etc.

Indoor unit

- Two configurations are available, depending on the indoor air flow direction: "Standard" (all models) and "In-line" (models 052 to 093).

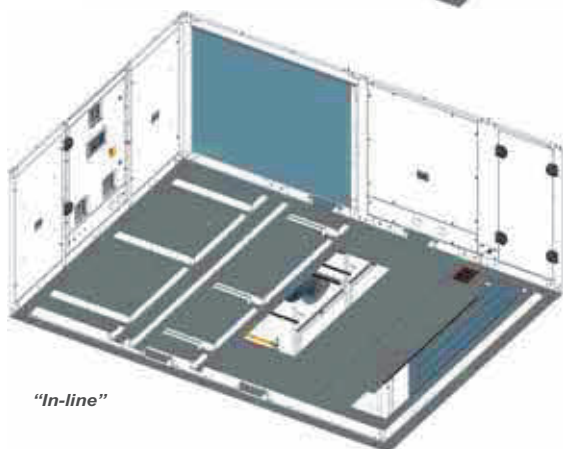
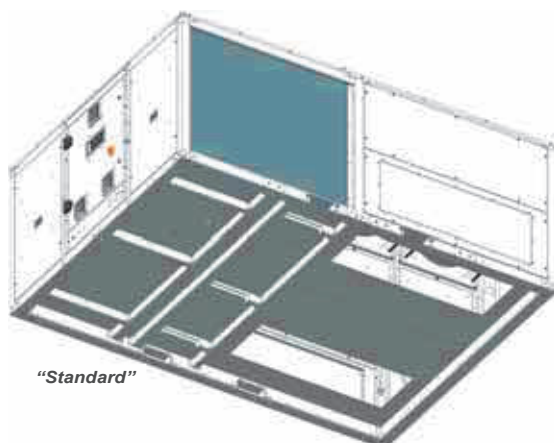

- Thermal and acoustic insulation, in double wall panels and registers, with Euroclass A2-s1, d0 (M0) fire classification.
- Coil with copper pipes and aluminium fins.
- EC electronic supply plug-fans directly coupled with variable control speed and flow rate controller.

- Reusable gravimetric air filters G4, mounted on a frame. Dual locking system mounted on the access panel to filters.
- Removable and isolated condensates drain pan for easy cleaning.

Outdoor unit

- Coil with copper pipes and aluminium fins.
- EC electronic axial fan(s) which adapt the rotation speed to the installation's requirements, thereby reducing electricity consumption, the sound level at partial charge and improving the unit's average seasonal efficiency.
- The cover with the motor fan(s) may be lifted to access the inside of the outdoor unit.

Cooling circuit

- Hermetic scroll-type compressors in tandem design that improves the management of stages and the part load efficiencies. Sound insulation, assembled over antivibration mounts. Control of phase equilibrium and the direction of rotation.
- Crankcase heater.
- Electronic expansion valve(s).
- Four-way cycle reversing valve(s) (heat pump units).
- Acid-resistant filter(s) dryer.
- Cooling design with 1-air volume (models 020 to 047) or 2-air volumes (models 052 to 093).

Protections

- High pressure pressostat(s).
- High and low pressure transducers.
- Compressor discharge temperature control.
- Main door switch.
- Magnetohermic protection switches for the power line of compressors and fan motors.
- Automatic switch in the control circuit.

Electrical cabinet

- Complete and fully wired electrical cabinet. Insulated access door to prevent condensation. Forced ventilation of the electrical cabinet. Protection IP54.
- Numeration of wired and identification of components in the electrical cabinet. It permits easy tracing and diagnostics.
- Hinges + quarter-turn latches on the removable access door.
- Electrical power supply with neutral.
- Main ground connection.
- Compressor and fan motor contacts.

OPERATING LIMITS

Inlet air conditions		Cooling
Indoor coil	Minimum temperature	13°C WB
	Maximum temperature	24°C WB
Outdoor coil	Minimum temperature	12°C (1)
	Maximum temperature	48°C

Inlet air conditions		Heating
Indoor coil	Minimum temperature	10°C
	Maximum temperature	27°C
Outdoor coil	Minimum temperature	-15°C WB (2)
	Maximum temperature	15°C WB

(1) With a condensation pressure control operating down to -10°C.

(2) When the outdoor temperature is usually below 5°C WB, the installation of a support element is recommended.

CONTROLS

“50FC” control

Factory-installed “50FC” control provide the capability for free standing operation or may be linked with a more extensive system. Factory-installed and programmed Modbus communication capability provides simple integration with the building BMS system.

The 50FC series may also be configured to communicate via LonWorks®, BACnet™ and Konnex protocols, if required by the application.

The “50FC” control also have the capability to communicate with our supervision solutions: **pCO Web**, **PlantWatchPRO3** and **PlantVisorPRO2**.

This communication flexibility allows simple system integration, as well as data collection, trending, monitoring and alarm displays. The control provides unparalleled service diagnostic information.

This control also manages a local connection between units through a pLAN network (Local Area Network), allowing data and information to be exchanged between units, for a maximum of 15 units.

The “50FC” control are your link to a world of simple and easy-to-use rooftop units that offer outstanding performance and value. With the sensors, it maintains control over all the components of the unit and helps optimise the performance of the refrigeration circuits as conditions change, resulting in the following features:

- Higher part load efficiency.
- Better control of temperature.
- Superior reliability.
- High ambient cooling operation at 48°C.
- Low ambient cooling operation at -15°C WB.

The main functions of this control are:

- Selection of set-point and operating mode: HEATING / COOLING / AUTO / VENTILATION.
- Continuous control of the operating parameters.
- Display of the values measured by the sensors.
- Compressors cycles.
- Defrosting management.
- Control of the supply air temperature.
- All-seasons operation via the condensation and evaporation pressure control.
- Set-point compensation based on the outdoor temperature.
- Hourly and weekly schedule.
- Fire protection.
- Diagnosis of faults and general alarm.
- Management of all the optional components available for the unit: economizer, back-up heating, CO2 air quality sensor, energy recovery,...

User interfaces

Graphic terminal

This terminal, fitted as standard on the electrical cabinet, is very easy to use. It provides detailed explanations of control in easy to understand English. No decoding is required.



Only 6, large, easy-to-use buttons are required to maneuver through the entire menus.

- This terminal is used to:
 - Carry out initial programming of the unit.
 - Modify operating parameters.

- Switch the unit ON / OFF.
- Select the operating mode and adjust the set-points.
- Display the variables controlled and sensor values measured.
- Display the current alarms and their historical record.

User terminal (optional)

This terminal can be installed on the electrical cabinet, instead of the graphic terminal. In this case, the remote connection of the graphic terminal is possible. Please consult the chapter “Factory options and accessories”.



- This terminal is used to:
 - Switch the unit ON / OFF.
 - Select the operating mode and adjust the set-points.
 - Display the installation’s temperatures and humidity, outdoor temperature, supply air temperature, CO₂ sensor and opening of the outdoor damper.
 - Display alarms codes.

Supervision solutions

Different solutions of supervision are available bases on the dimensions of the installation for unit fitted with A BMS card (Ethernet pCO Web or RS485 Carel / Modbus).

pCO Web

- It is the solution for the management and supervision of a single unit if this incorporates the Ethernet pCO Web card.

PlantWatchPRO3

- This is a solution designed for the monitoring of small and medium-size installations, capable of manage up to 30 units. Suitable for technical environments, no parts are in movement. It’s available in two versions: panel and wall.

Includes: 7 “ touch display, buzzer for notifications, 1 USB port and 1 SD card slot for downloading reports, charge devices models and applying service packs.

For this option, each unit needs one RS485 Carel / Modbus board.

PlantVisorPRO2

- This is the solution for the management and supervision of air-conditioning installations with up to 300 units. It offers advanced monitoring and maintenance functions and allows zones and groups to be created to simplify the management of the installation. It also allows energy meters to be integrated to monitor the installation electricity consumption.

PlantVisorPRO2 is available in two versions:

- **Box:** comprised of CPU and, optionally, by monitor and keyboard.
- **Touch:** this includes CPU and touchscreen in a single device.

For this option, each unit needs one RS485 Carel / Modbus board.

These systems are used to manage the installation remotely. All the information on the system can be accessed via a simple Internet connection. The online interface, the same one used by the local user, enables monitoring and complete configuration of the installation: from the office or anywhere else the user happens to be.

To control multiple sites remotely, there are special tools dedicated to centralized management, such as **RemotePRO** and **RemoteValue**.

PHYSICAL DATA (EN-14511-2018)

50FC		020	028	037	040	045	047	052	058	062	070	074	086	093
Cooling capacities														
Cooling capacity (1)	kW	22,31	27,78	33,44	36,90	41,50	43,92	53,22	57,80	60,39	68,26	72,22	80,66	90,18
Power input (3)	kW	7,00	8,98	10,25	11,79	13,40	14,26	16,53	18,38	19,38	21,27	22,89	25,77	28,94
EER performance		3,19	3,09	3,26	3,13	3,10	3,08	3,22	3,14	3,12	3,21	3,15	3,13	3,12
SEER		4,03	4,04	4,07	4,06	4,05	4,03	4,12	4,17	4,17	4,11	4,06	4,07	4,07
ηs		158%	159%	160%	159%	159%	158%	162%	164%	164%	161%	160%	160%	160%
Heating capacities														
Heating capacity (2)	kW	21,88	27,72	33,05	36,61	41,82	44,56	50,71	55,79	58,57	67,68	71,77	80,38	89,66
Power input (3)	kW	5,82	7,99	9,09	10,21	12,00	12,95	14,43	16,01	16,89	18,97	20,27	22,91	25,90
COP performance		3,76	3,47	3,64	3,59	3,49	3,44	3,51	3,48	3,47	3,57	3,54	3,51	3,46
SCOP		3,47	3,46	3,45	3,45	3,46	3,46	3,57	3,59	3,52	3,52	3,55	3,59	3,58
ηs		136%	136%	135%	135%	135%	135%	140%	141%	138%	138%	139%	141%	140%
Outdoor circuit fan														
Electronic axial fan														
Nominal air flow	m ³ /h	9.000	14.500	17.000	17.000	17.000	17.750	31.000	31.000	31.000	33.000	33.000	34.500	35.000
Available static pressure	mm.w.c	5												
Number / Diameter	mm	1 / 630					1 / 800					2 / 800		
Motor output	kW	0,9					2,6					2 x 2,6		
Maximum speed	r.p.m.	1.140					1.020					1.020		
Maximum absorbed current	A	1,6					3,9					7,8		
Indoor circuit supply fan														
Electronic plug-fan														
Nominal air flow	m ³ /h	5.100	6.500	8.500	8.750	9.000	9.000	12.000	12.500	12.500	15.500	15.500	16.000	16.000
Available static pressure	mm.w.c	12	12	12	15	15	15	20	20	20	20	20	20	25
Number / Diameter	mm	1 / 500		1 / 500				2 / 500				2 / 500		
Motor output	kW	1 x 2,65		1 x 2,83				2 x 2,65				2 x 2,83		
Power input	kW	0,62	1,01	1,79	1,90	2,00	2,04	2,04	2,20	2,20	3,53	3,53	3,42	3,75
Speed	r.p.m.	1.700												
Maximum absorbed current	A	4,2		4,3				8,4				8,6		
Compressor														
Scroll														
No. compressors / stages / circuits		2 / 2 / 1						4 / 4 / 2						
Oil type		Copeland 3MAF 32cST, Danfoss POE 160SZ, ICI Emkarate RL 32CF, Mobil EAL Artic 22CC												
Volume of oil	l	2,5	2,5	3,3	3,5	3,5	3,5	5,0	5,0	5,8	6,6	6,9	7,1	7,1
Electrical characteristics														
Mains voltage		400 V / III ph / 50 Hz (±10%)												
Power supply		3 Wires + Ground + Neutral												
Maximum absorbed current	A	18,9	26,5	26,4	29,9	33,6	34,0	48,1	53,5	53,2	56,3	60,2	68,8	73,8
Refrigerant														
R-410A														
Global warming potential (4)	GWP	2.088												
Charge	kg	8,0	8,3	11,0	11,0	11,3	11,6	12,5	12,8	13,0	20,0	20,3	20,3	20,5
Environment impact	tCO ₂ eq	16,7	17,3	23,0	23,0	23,6	24,2	26,1	26,7	27,1	41,8	42,4	42,4	42,8
Weight														
B1 assembly	kg	585	610	675	680	685	690	990	995	1.040	1.155	1.160	1.165	1.170

- (1) Cooling capacity calculated in accordance with the EN-14511-2018 standard given for indoor temperature conditions 27°C, 19°C WB and 35°C outdoor temperature.
- (2) Heating capacity calculated in accordance with the EN-14511-2018 standard given for indoor temperature conditions 20°C and 6°C WB outdoor temperature.
- (3) Total power input by compressors and motorised fans under nominal conditions, calculated in accordance with the EN-14511-2018 standard.
- (4) Climatic warming potential of a kilogram of fluorinated greenhouse gas in relation to a kilogram of carbon dioxide over a period of 100 years.

COMPLIANCE

- Machinery Directive 2006/42/EC (MD)
- Electromagnetic Compatibility Directive 2014/30/EU (EMC)
- Low Voltage Directive 2014/35/EU (LVD)
- Pressure Equipment Directive 2014/68/EU (Category 2) (PED)
- RoHS Directive 2011/65/EU (RoHS)
- Eco-design Directive 2009/125/EC (ECO-DESIGN)
- Energy Labelling Directive 2017/1369/EU (ECO-LABELLING)
- Harmonised Standard: EN 378-2:2012 (Refrigerating systems and heat pumps - Safety and environmental requirements).

FACTORY OPTIONS AND ACCESSORIES

Summary table

Category	Description	Factory installed option	Field installed accessory	Models
Electrical power Flow + Assembly	400 V / 3 ph / 50 (without neutral)	X		All
	B2: Standard. Economizer, 2 dampers	X		All
	B3: Standard. Economizer, 3 dampers	X		All
	BX: Standard. Axial fan in return section	X		All
	BP: Standard. EC plug-fan in return section	X		All
	BA: Standard. Cooling recovery circuit with EC plug-fan in return section	X		All
	BT: Standard. Return top box with EC plug-fan	X		All
	BB: Standard. Cooling recovery circuit with EC plug-fan in return top box	X		All
	BW: Standard. Heat recovery wheel module	X		All
	R2: In-line. Economizer, 2 dampers	X		052 to 093
	RP: In-line. EC plug-fan in return section	X		052 to 093
	RW: In-line. Heat recovery wheel module	X		052 to 093
Coil coating	Coils with copper-made pipes and fins	X		All
	INERA® coils with aluminium alloy fins and copper pipes	X		All
	Coils with polyurethane pre-coated aluminium fins and copper pipes	X		All
	Blygold® coating	X		All
Heating	Auxiliary hot water coil : Standard or Very low outdoor temperature	X		All
	Auxiliary electrical heaters	X		All
	Warm air heater module with gas burner (supplied installed inside a pre-assembly roofcurb)		X	All
	Gas-fired condensing boiler with hot water coil	X (*)		All
Protection low temperature	Freeze protection OAT lower than -10°C	X		All
	Freeze protection OAT lower than -14°C	X		All
	Freeze protection OAT lower than -10°C + spring shut-off dampers	X		All
	Freeze protection OAT lower than -14°C + spring shut-off dampers	X		All
Supply fan	High available pressure of the supply fan	X		All
	Low available pressure of the supply fan	X		All
Air filtration + droplet eliminator	Droplet eliminator after the indoor air coil	X	X	All
	Low pressure drop G4 filters	X	X	All
	G4 filters + M6, F7 or F9 folded filters	X	X	All
	Low pressure drop G4 filters + F7 or F9 folded filters	X	X	All
	Double stage of folded filters: M6+F7, M6+F9, F7+F9 or F9+F9	X	X	All
Outdoor fan	Two-speed direct-driven axial fans	X		All
Insulation	Thermal and acoustic insulation, Euroclass A2-s1, d0 (M0), in ceramic fibre	X		All
Indoor unit	Condensates drain pan in stainless steel	X	X	All
	Room overpressure management	X		All
	Filter fouling detection with differential pressure switch	X		All
Outdoor unit	Outdoor coil protection grid	X	X	All
	Droplet eliminator at the fresh air intake	X	X	All
	Antivibration mounts made of rubber	X	X	All
Heat recovery wheel	Selection of the heat recovery wheel (BW assembly): wheel materials, channel cross section, air filtration and type of speed control	X		All
	Selection of the heat recovery wheel (RW assembly): wheel materials, channel cross section, air filtration and type of speed control	X		All
Sensors	NTC ambient temperature sensor connected to the control board or up to four sensors with RS485 communication	X	X	All
	Dual ambient temperature-humidity sensor with RS485 communication. Up to four sensors	X	X	All
	CO2 sensor: environment or ducted installation or installed on a pLAN network	X	X	All
	Smoke detection control unit in accordance with the NF S 61-961 standard	X	X	All
Economizer management + Outd. humidity	Economizer management: thermal, enthalpic or thermoenthalpic	X	X	All
	Outdoor air humidity sensor: supplied with the unit or installed on a pLAN network	X	X	All
Terminal + Unit communication	User terminal installed in the electrical cabinet	X	X	All
	Graphic terminal installed in the electrical cabinet + user terminal remote up to 100 m	X	X	All
	User terminal installed in the electrical cabinet + graphic terminal remote up to 200 m	X	X	All
	Graphic terminal installed in the electrical cabinet + Graphic terminal remote up to 200 m	X	X	All
	Unit configuration: stand-alone, master or slave	X	X	All
	Communication cards: RS485 Modbus/Care!; Ethernet PCoWeb; RS485 LonWorks®; Ethernet BACnet™; RS485 BACnet™; RS485 Konnex	X	X	All
Miscellaneous item 1	Management of an humidifier with on-off or proportional control	X		All
	Electrical energy meter	X		All
	Cooling capacity and electrical energy meter	X		All
Miscellaneous item 2	Compressor soft-starter	X		All
	Varnish protection for components on the electrical cabinet: control board, cards and terminals	X		All
	High performance phase sequence relay	X		All
	High grade switching devices	X		All
Roofcurb	Pre-assembly roofcurbs with adjustable height		X	"Standard"
	Adaptation roofcurbs for replacing units on renovation		X	"In-line"

(*) Part of this option must be installed on-site.

FACTORY OPTIONS AND ACCESSORIES (CONT.)

Assembly + indoor air flow direction (B: "Standard" & R: "In-line")

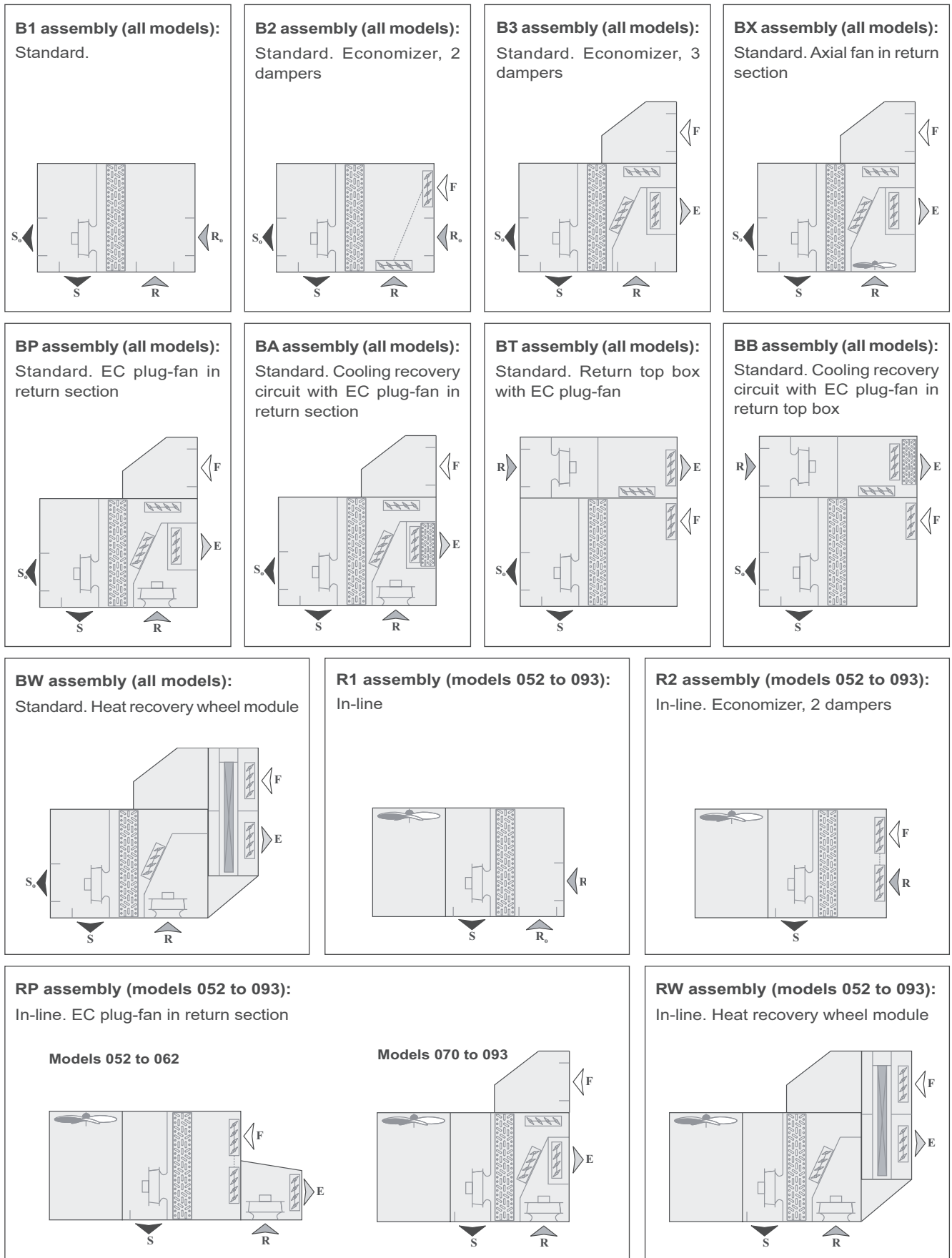

S: standard supply S_o: on-site supply configuration R: standard return R_o: on-site return configuration F: fresh air intake E: air exhaust

AIR TREATMENT

FACTORY OPTIONS AND ACCESSORIES (CONT.)

Active recovery (BA and BB assemblies)

The unit is fitted with a thermodynamic circuit dedicated to the recovery of the extracted air energy, with independent and proportional control, adapted to the air renewal requirements in order to raise the COP, EER and seasonal efficiency.

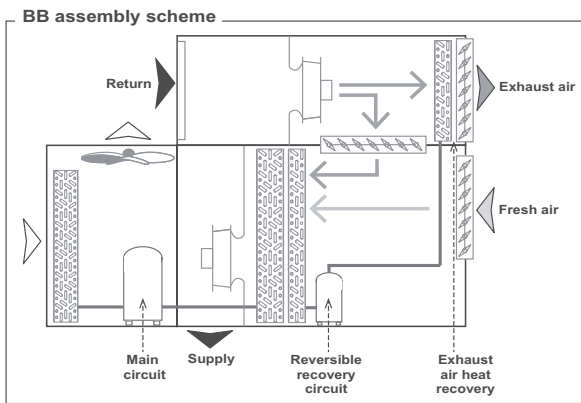
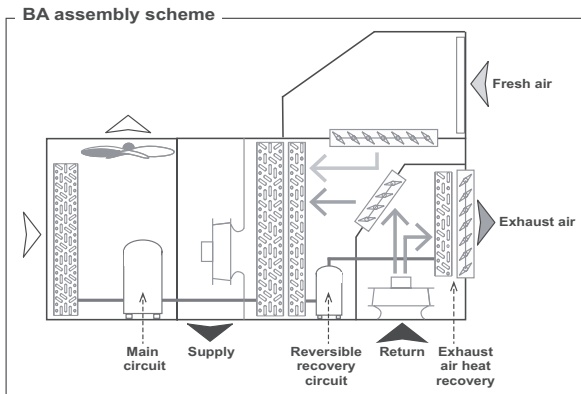

Passive recovery (BW and RW assemblies)

The heat recovery wheel is used to transfer the sensible and latent heat from the air-conditioned room's return air to the fresh air used for ventilation, before it's discharged outdoors. The return air circulates in half of the heat recovery unit and the ventilation air circulates in the other half, in the opposite direction. As the rotor rotates, very fine channels of air which form the matrix come into contact with the fresh air and the return air in turn, thereby transferring heat and humidity from one to the other.

The efficiency of energy recovery depend on the wheel selected: wheel material, channel cross section, air filtration and type of speed control.

The heat recovery wheel is fitted into a module placed on one side of the unit (assemblies BW and RW). This module is supplied disassembled with the unit, for installation on site.

Electrical power

- These units can be supplied for the following power supply voltages:
 - 400 V / 3 ph + N / 50 Hz (standard)
 - 400 V / 3 ph / 50 Hz (optional)

Coils coating

- Coil with copper-made pipes and fins. Upon request.
- INERA® coils with aluminium alloy fins of high performance and great resistance to the corrosion, and copper pipes.

- Coils with polyurethane precoated aluminium fins and copper pipes.

- Blygold® coating.

Note: These coating can be applied to various coils (outdoor, indoor and hot water coil) according to the combinations available in our "Selection Software".

Heating

The unit only can incorporate one of these heating elements:

- **Auxiliary electrical heaters**, with two power stages and on/off control, for assembly and connection inside the unit.
 - Up to 3 values of total power available for each model:

50FC	020 to 047	052 to 062	070 to 093
RAF (Low)	12 kW	12 kW	18 kW
RAM (Nominal)	18 kW	18 kW	27 kW
RAS (High)	unavailable	27 kW	36 kW

- **Auxiliary hot water coil**, with three-way valve and proportional control, for assembly inside the unit.

- The unit incorporates a freeze protection thermostat.
- There are two configuration types available:
 - Standard (HAS), the only safety system is the freeze protection thermostat.
 - Very low outdoor temperature (HAF), with freeze protection technology based on the water temperature. This protection is made up of a circulation pump, two sensors inserted in the input and the output of the coil, as well as an electrical heating for the piping layout. Important: this option is mandatory for an outdoor temperature lower than -20°C WB. Consult for percentages of glycol water above 20%.

Note: on units with this option, air supply only may be lateral (factory-configured).

- **Gas-fired condensing boiler with hot water coil.** Natural or propane gas boiler with modulating actuator, in accordance with the Gas Directive 2009/142/EC, mounted on the side of the unit.

- The boiler is connected to the water circuit of the auxiliary coil.

- Up to 3 values of total power available for each model:

50FC	020 to 047	052 to 062	070 to 093
BBF (Low)	unavailable	Condexa PRO 50 (coming soon)	Condexa PRO 50 (coming soon)
BBM (Nominal)	Condexa PRO 40 (coming soon)	Condexa PRO 70	Condexa PRO 70
BBS (High)	Condexa PRO 70	Condexa PRO 100	Condexa PRO 100

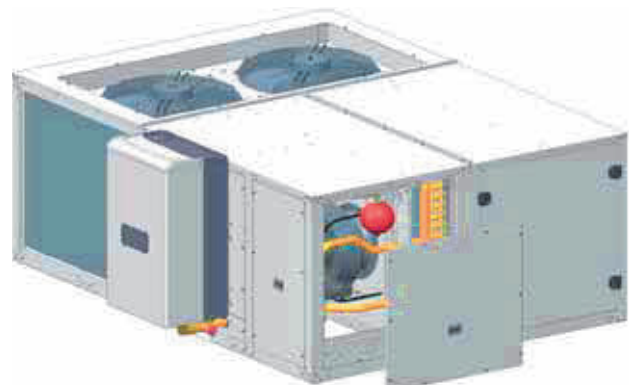

FACTORY OPTIONS AND ACCESSORIES (CONT.)

- **Warm air heater module with gas burner** with modulating actuator, in accordance with the Gas Directive 2009/142/EC, installed inside a pre-assembly roofcurb.
 - Condensation boiler with premixing and modulation technology that allows outputs close to 109% with regard to the lower heating value (LCV).
 - Up to 3 values of total power available for each model:

50FC	020 to 047	052 to 062	070 to 093
BAF (Low)	PCH020	unavailable	unavailable
BAM (Nominal)	PCH034	PCH065	PCH080
BAS (High)	PCH045	PCH080	PCH105

Note: It's recommended to use the clogged filter pressostat (optional) in units with gas burner.

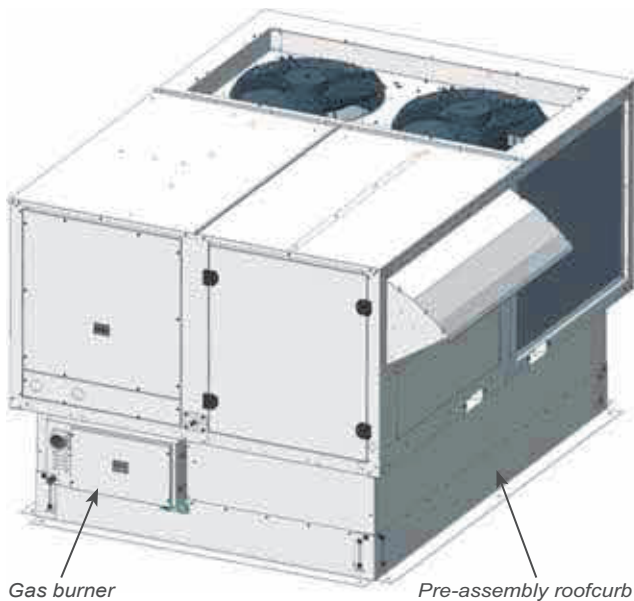

Protection for low outdoor temperature

- Freeze protection OAT lower than -10°C . Mandatory for an outdoor temperature lower than -10°C WB.
 - Electrical heater for protection of the components of the electrical cabinet.
 - Compressor with protection for low temperature.
- Freeze protection OAT lower than -14°C . Mandatory for an outdoor temperature lower than -14°C WB.

In addition to the options of -10°C , this includes:

 - Reinforced electrical heater for protection of the components of the electrical cabinet.
 - Electrical heater for anti-freeze protection of dampers of the economizer (if applicable).
 - Protective kit of the gas burner for low temperature (if applicable).
- Freeze protection OAT lower than -10°C + spring shut-off dampers in case of a power failure.
- Freeze protection OAT lower than -14°C + spring shut-off dampers in case of a power failure.

Supply fan

- There are 3 optional fans depending on the available pressure:
 - Low pressure (F): all models except for 070 and 074.

- Nominal pressure (N): all models.
- High pressure (S): models 052 to 093.

Important: our "Selection Software" will choose the supply fan with lower consumption for the available pressure required.

Air filtration + Droplet eliminator

Options to improve indoor air quality:

- G4 gravimetric filters with low pressure drop.
- G4 gravimetric filters + M6, F7 or F9 folded opacimetric filters.
- G4 gravimetric filters with low pressure drop + F7 or F9 folded opacimetric filters.
- Double-stage of folded opacimetric filters (M6+F7, M6+F9, F7+F9 or F9+F9).
- Droplet eliminator after the indoor air coil. Recommended in cases where a high moisture content in the air is foreseen or when the air flow is high.

Note: with hot water coil it is not possible to assemble the droplet eliminator.

Outdoor fan

- Two-speed direct-driven axial fan(s). Watertight motor class F, IP54 and internal thermal protection. Dynamically balanced propellers and outdoor protective grille.

Insulation

- Thermal and acoustic insulation in ceramic fibre, Euroclass A2-s1, d0 (M0) fire classification.

Note: panels and registers of the indoor unit always include thermal and acoustic insulation, with Euroclass A2-s1, d0 (M0) fire classification.

Indoor unit

- Condensate drain pan in stainless steel for corrosion protection.
- Room overpressure management (available in BP, BT, BW, RP and RW assemblies). In installations with different air flow in supply and return, to prevent the entry of outdoor air or to eliminate odours from inside, the fresh air damper and the exhaust damper will be managed independently.
- Filter fouling detection with differential pressure switch.

Outdoor unit

- Outdoor coil protection grid.
- Droplet eliminator at the fresh air intake. This one and the thermoenthalpic free-cooling are necessary in cases where a high moisture content in the air is foreseen.
- Antivibration mounts made of rubber.

Heat recovery wheel

- The heat recovery wheel is fitted into a module placed on one side of the unit (BW and RW assemblies).

The efficiency of energy recovery depend on the wheel selected: wheel material, channel cross section, air filtration and type of speed control.

FACTORY OPTIONS AND ACCESSORIES (CONT.)

Sensors

- Ambient temperature sensor(s). There are 3 options:
 - One NTC sensor connected to the control board.
Note: An ambient sensor with RS485 communication is required for installation at more than 30 meters.
 - Up to four sensors with RS485 communication.
 - Sensor(s) installed on the master unit of the local network (pLAN).
- Dual ambient temperature-humidity sensor(s). Up to four sensors with RS485 communication or installed on the pLAN network. This sensor is compulsory in units with enthalpic or thermoenthalpic free-cooling (optional). In this case, the outdoor air humidity sensor is also added.
- CO₂ sensor for air quality control. There are 3 options:
 - Sensor for installation in the environment.
 - Sensor for ducted installation.
 - Sensor installed on the master unit of the local network (pLAN).
- Smoke detection control unit in accordance with the NF S 61-961 standard.

Economizer management + outdoor humidity

- The economizer allows to make best use of outdoor air conditions when these are more favourable than the return air conditions. This allows the cooling capacity to be reduced. The percentage of outdoor air can vary between 0% and 100%.
The economizer management can be:
 - Thermal, by comparing the temperatures.
 - Enthalpic, by comparing the enthalpies. Recommended in cases where a high moisture content in the air is foreseen.
 - Thermoenthalpic, by comparing the enthalpies and correcting for temperature. This is the optimum solution as it takes the variability of the climate into account.
- Outdoor air humidity sensor (compulsory in units with optional enthalpic or thermoenthalpic free-cooling). There are 2 options:
 - Sensor supplied with the unit.
 - Sensor installed on another unit of the local network (pLAN).

Terminal + unit communication

- By default, the electronic control is supplied with a graphic terminal installed in the electrical cabinet of the unit, but these other configurations also are available:
 - User terminal installed in the electrical cabinet, instead of the graphic terminal.
 - Graphic terminal installed in the electrical cabinet and user terminal remote up to 100 meters.
 - User terminal installed in the electrical cabinet and graphic terminal remote up to 200 meters (two TCONN bypass cards must be used from 50 to 200 meters).
 - Graphic terminal installed in the electrical cabinet and graphic terminal remote up to 200 meters (two TCONN bypass cards must be used from 50 to 200 meters).
 - Control without terminal (for units with shared terminal in a pLAN network).
- By default, the electronic control is configured for a stand-alone unit, but it is also possible to place it in a pLAN network (Local Area Network) as Master or Slave.
- This control allows the connection to a centralised technical management system by using a specific BMS card for some of the following communication protocols:

- RS485 serial cards for network communication with protocols: Carel, Modbus, LonWorks®, BACnet™ MSTP, Konnex.
- Ethernet pCO Web card for network communication with protocols: Modbus TCP/IP, BACnet™ Ethernet, TCP/IP, SNMP V1-2-3, FTP and HTTP.

Miscellaneous item 1

- Management of an humidifier with on-off or proportional control.
- Electrical energy meter for monitoring of the power consumption of the installation.
- Cooling capacity and electrical energy meter. In addition to the energy meter, the unit incorporates mixing and supply enthalpic sensors with RS485 communication that enable cooling and heating capacities to be calculated.

Miscellaneous item 2

- Compressor soft starter.
- High performance phase sequence relay, which allows the protection settings to be adjusted (highly recommended for installations with power system voltage instability, lag between current and voltage, high level of electromagnetic disturbances EMC, etc).
- High grade switching devices.
- Varnish protection for the components on the electrical cabinet: control board, cards and terminals.

Pre-assembly roofcurbs

- “Standard” assemblies can rest on pre-assembly roofcurbs with adjustable height, built in galvanised steel panelling with polyester paint and thermal insulation.
The levelling system uses angle pieces that allow adjustments in the X and Y axes.

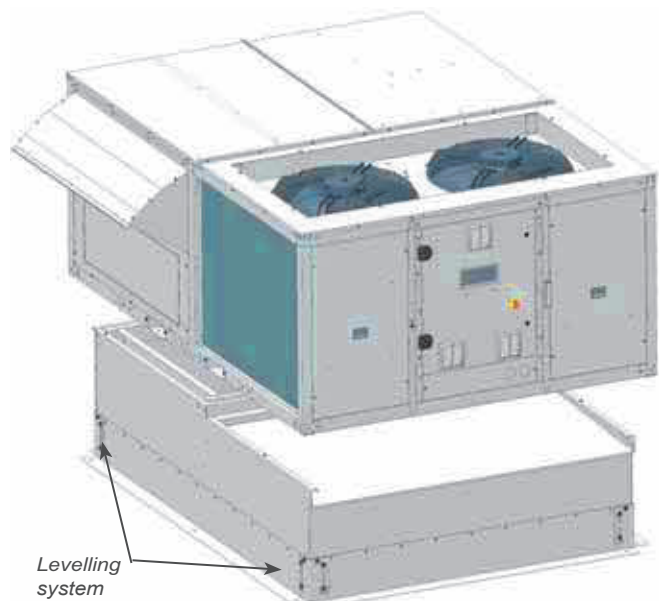

- “In-line” assemblies have a wide range of adaptation roofcurbs which are ready for replacing units on renovation from different manufacturers (upon request).

SOUND LEVELS dB(A)

Sound power level (LW)

50FC	020	028	037	040	045	047	052	058	062	070	074	086	093
63 Hz	55,2	60,8	61,4	60,9	61,3	63,1	64,3	64,5	64,9	64,8	64,6	64,6	65,3
125 Hz	64,2	66,7	68,9	66,1	70,0	71,1	69,6	69,9	71,5	72,4	71,3	71,4	74,0
250 Hz	71,8	74,8	76,1	72,9	76,3	76,4	77,0	77,7	78,9	79,7	78,4	77,9	79,3
500 Hz	70,2	76,7	76,4	76,8	77,1	78,3	79,5	80,1	80,4	79,9	80,1	80,2	80,9
1000 Hz	72,0	76,2	76,3	77,5	77,3	78,2	79,4	79,9	80,2	79,8	80,4	80,6	80,7
2000 Hz	69,7	73,5	74,3	75,3	74,1	75,5	77,0	77,4	77,8	77,7	78,3	78,1	77,7
4000 Hz	62,6	69,2	70,3	70,6	70,4	72,2	73,1	73,4	73,7	73,8	73,9	74,2	74,4
8000 Hz	59,0	63,7	65,5	65,8	65,6	67,5	67,9	68,2	68,6	68,9	69,1	69,4	69,6
Total dB(A)	77,5	82,0	82,5	82,5	83,0	84,0	85,0	85,5	86,0	86,0	86,0	86,0	86,5

Sound pressure level (LP)

Measurement conditions: in a clear field, measured at a distance of 5 metres, directivity 2 and at 1,5 metres from the ground.

50FC	020	028	037	040	045	047	052	058	062	070	074	086	093
Total dB(A)	51,0	55,5	56,0	56,0	56,5	57,5	58,3	58,8	59,3	59,3	59,1	59,1	59,6

Note: The sound pressure level depends on the installation conditions and, as such, it only indicated as a guide. Values obtained according to the ISO 3744 standard.

ELECTRICAL CONNECTIONS

No.	50FC	020 to 093
1	Main power supply	400 III ($\pm 10\%$)
2	Remote connection of graphic terminal (by default installed on the electrical cabinet) (1)	Telephone cable 6 wires standard (RJ12 connector)
4	Remote off/on (optional)	2 wires
5	General fault signal (optional)	2 wires
6	Circulation pump signal for HWC (antifreeze safety) (optional)	1 wire
7	Ambient sensor	NTC
8		RS485
9	CO2 sensor (optional)	3 wires

(1) In this case, it's possible to install the user terminal on the electrical cabinet.

(2) Up to four RS485 ambient sensors can be connected in series on the field-bus of the control board.

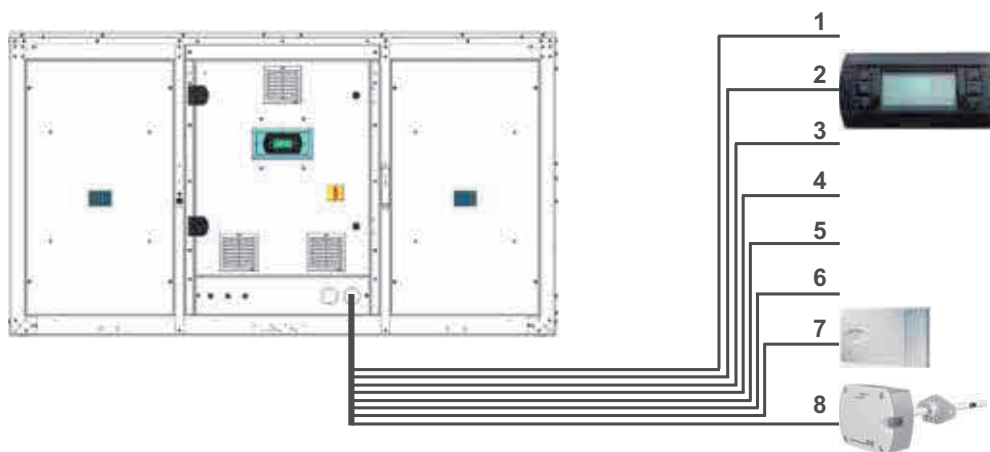

OPTIONS FOR THE OUTDOOR UNIT

Axial 2-speed outdoor fan

50FC	020	028	037	040	045	047	052	058	062	070	074	086	093
Nominal air flow (m ³ /h)	9.000	14.500	17.000	17.000	17.000	17.750	31.000	31.000	31.000	33.000	33.000	34.500	35.000
Available static pressure (mm.w.c.)	4												
Number (mm)	1	1					2						
Diameter (mm)	630	800					800						
Output (kW)	0,4 / 0,6	1,2 / 1,9					2 x (1,2 / 1,9)						
Maximum speed (r.p.m.)	690 / 840	670 / 880					670 / 880						
Max. absorbed current (A)	1,2	3,9					2 x 3,9						

OPTIONS FOR THE INDOOR UNIT

Droplet eliminator after the indoor air coil

Air flow at which it is recommended to install a droplet eliminator after the indoor coil.

50FC	020	028	037	040	045	047	052	058	062	070	074	086	093
Air flow (m ³ /h)	7.776	7.776	10.206	10.206	10.206	10.206	14.580	14.580	14.580	14.580	18.468	18.468	18.468

Note: for operating conditions with high dehumidification in the indoor coil (e.g. in installations close to the coast) it may be necessary to install a separator even if the flow is less than the previous one.

Note: with hot water coil it is not possible to assemble the droplet eliminator.

Supply plug-fan EC with high (S) or low (F) available pressure

50FC	020	028	037	040	045	047	052	058	062	070	074	086	093
Nominal air flow (m ³ /h)	5.100	6.500	8.500	8.750	9.000	9.000	12.000	12.500	12.500	15.500	15.500	16.000	16.000
Nominal available static pressure (mm.w.c.)	12	12	12	15	15	15	20	20	20	20	20	25	25
Low pressure (F)	Number / Diameter (mm)	1 / 500			--			--				2 / 500	
	Output (kW)	1,3			--			5,6				2 x 2,6	
	Speed (r.p.m.)	1.350			--			2.200				1.700	
	Max. absorbed current (A)	2,1			--			8,9				2 x 4,0	
High pressure (S)	Number / Diameter (mm)	--			2 / 500			2 / 500					
	Output (kW)	--			2 x 2,6			2 x 5,6					
	Speed (r.p.m.)	--			1.700			2.200					
	Max. absorbed current (A)	--			2 x 4,2			2 x 8,4					

Note: the value of power input according to the selected flow can be found at our "Selection Software".

Axial fan in return section (BX assembly)

50FC	020	028	037	040	045	047	052	058	062	070	074	086	093
Maximum air flow (m ³ /h)	5.100	6.500	8.500	8.750	9.000	9.000	12.000	12.500	12.500	15.500	15.500	16.000	16.000
Available static pressure (mm.w.c.)	5												
Number / Diameter (mm)	1 / 500		2 / 450				2 / 500			3 / 500			
Output (kW)	0,7		2 x 0,5				2 x 0,7			3 x 0,7			
Speed (r.p.m.)	1.390		1.360				1.390			1.390			
Maximum absorbed current (A)	1,4		2 x 1,0				2 x 1,4			3 x 1,4			

OPTIONS FOR THE INDOOR UNIT (CONT.)

EC plug-fan in return section (BP / BA / BT / BB / RP assemblies)

50FC		020	028	037	040	045	047	052	058	062	070	074	086	093
Nominal air flow	(m ³ /h)	5.100	6.500	8.500	8.750	9.000	9.000	12.000	12.500	12.500	15.500	15.500	16.000	16.000
Nominal available static pressure	(mm.w.c.)	12	12	12	15	15	15	20	20	20	20	20	25	25
Number / Diameter	(mm)	1 / 500						2 / 500						
Output	(kW)	2,6						2 x 2,6						
Speed	(r.p.m.)	1.700						1.700						
Maximum absorbed current	(A)	4,0						2 x 4,0						

Note: the value of power input according to the selected flow can be found at our "Selection Software".

EC plug-fan in return section (BW / RW assemblies)

50FC		020	028	037	040	045	047	052	058	062	070	074	086	093	
Nominal air flow	(m ³ /h)	5.100	6.500	8.500	8.750	9.000	9.000	12.000	12.500	12.500	15.500	15.500	16.000	16.000	
Nominal available static pressure	(mm.w.c.)	12	12	12	15	15	15	20	20	20	20	20	25	25	
Nominal pressure (N)	Number / Diameter	1 / 500						2 / 500							
	Output	2,6						2 x 2,6							
	Speed	1.700						1.700							
	Max. absorbed current	4,0						2 x 4,0							
High pressure (H)	Number / Diameter	--	1 / 500						--	2 / 500					
	Output	--	2,8						--	2 x 2,8					
	Speed	--	1700						--	1.700					
	Max. absorbed current	--	4,3						--	2 x 4,3					

Note: the value of power input according to the selected flow can be found at our "Selection Software".

Heat recovery wheel module (BW / RW assemblies)

This heat recovery wheel is used to transfer the sensible and latent heat from the air-conditioned room's return air to the fresh air used for ventilation, before it's discharged outdoors.

The return air circulates in half of the heat recovery unit and the ventilation air circulates in the other half, in the opposite direction. As the rotor rotates, very fine channels of air which form the matrix come into contact with the fresh air and the return air in turn, thereby transferring heat and humidity from one to the other.

The efficiency of the recovery depends on the following factors:

■ Wheel diameters:

- 800 mm: models 020 to 047
- 1200 mm: models 052 to 062
- 1500 mm: models 070 to 093

■ Matrix materials:

- Aluminium: sensible heat recovery.
- Epoxy coated aluminium: sensible heat recovery in aggressive environments.
- Hybrid wheel: enthalpic recovery.
- Silicagel coated aluminium: enthalpic recovery with high efficiency in the recovery of latent heat.

■ Channel cross section:

The wheel is formed of two panels of aluminium, one smooth and one fluted. The fluted panel can be provided in two different configurations:

- 2.0 mm cross section: the commonly-used cross section due to its high efficiency and moderate pressure drops.
- 2.5 mm cross section: low pressure drop. Designed for high frontal speeds with low pressure drops.

The heat recovery wheel is fitted into a module placed on one side of the unit.

This module features filters on the fresh air intake and the exhaust air outlet: gravimetric filters G4 (default option), G4 with low pressure drop or G4 + M6 (optional).

This assembly can be supplied, in option, with a speed drive for the wheel which avoids the risk of ice forming on the wheel during the defrost operation. The speed drive is compulsory with output temperatures on both sides of the wheel lower than 1°C or an average temperature on the wheel lower than 3°C.

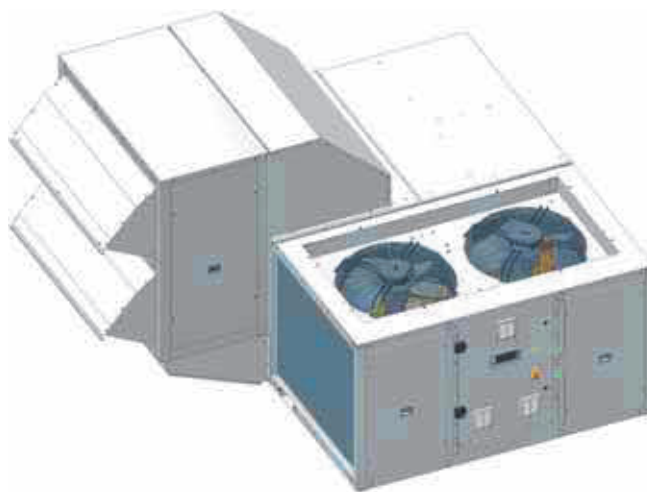

Important: the calculations for the selection of a heat recovery wheel according to the parameters described above should be done using our "Selection Software".

OPTIONS FOR THE INDOOR UNIT (CONT.)

Cooling recovery circuit (BA / BB assemblies)

Thermodynamic circuit dedicated to the recovery of the extracted air energy, with independent and proportional control, adapted to the air renewal requirements in order to raise the COP, EER and seasonal efficiency of the unit set.

- The circuit is composed of:
 - EC plug-fan in return section.
 - Air circuit comprised of coils with copper pipes and aluminium fins.
 - Electronic expansion valve.
 - Hermetic scroll-type compressor with sound insulation, assembled over antivibration mounts.
 - Crankcase heater.
 - Four-way cycle reversing valve.
 - Anti-acid dehydrator filter.
 - High and low pressure transducers.
 - Condensates drain pan.

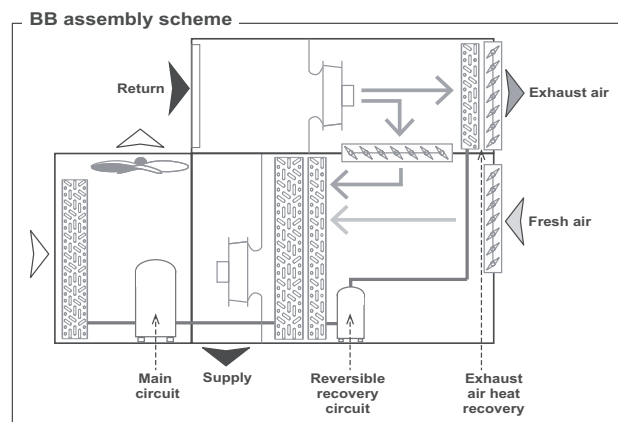
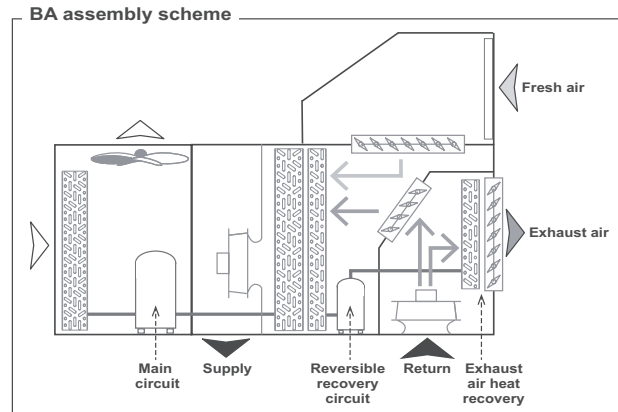

50FC	020 to 028	037 to 047	052 to 062	070 to 093
Compressor type	Scroll			
No. of compressors / circuits	1 / 1			
Max. absorbed current (A)	5,4	7,2	10,1	12,1
Oil type	Copeland 3MAF 32cST, Danfoss POE 160SZ, ICI Emkarate RL 32CF, Mobil EAL Artic 22CC			
Volume of oil (l)	0,7	1,2	1,7	1,8
Charge of R-410A (kg)	1,7	2,5	3,0	3,4
Environment impact (tCO ₂ eq)	3,5	5,2	6,3	7,1

Total cooling capacity with recovery circuit

50FC		020	028	037	040	045	047	052	058	062	070	074	086	093	
Nominal air flow	(m ³ /h)	5.100	6.500	8.500	8.750	9.000	9.000	12.000	12.500	12.500	15.500	15.500	16.000	16.000	
Outdoor temperature 35°C / 40% HR Indoor temperature 27°C / 50% HR	20% fresh air	Pft (kW)	29,6	36,2	45,7	49,4	54,2	56,5	70,4	75,4	77,8	90,6	94,5	103,2	112,4
		Pfs (kW)	23,7	29,6	38,1	40,2	42,4	43,3	55,9	59,0	59,9	72,1	73,6	78,1	81,6
		Pa (kW)	8,5	9,6	11,5	12,8	14,0	14,7	17,8	19,5	20,5	21,7	23,3	25,8	29,0
	40% fresh air	Pft (kW)	31,3	37,9	48,2	52,0	56,8	59,3	73,8	78,8	81,4	95,1	99,2	107,9	117,4
		Pfs (kW)	25,1	31,2	39,7	41,8	44,2	45,2	58,8	62,0	62,9	76,0	77,4	81,9	85,5
		Pa (kW)	8,1	9,3	10,9	12,3	13,5	14,2	17,1	18,9	19,9	20,9	22,5	25,1	28,3
	80% fresh air	Pft (kW)	33,7	40,3	51,9	55,7	60,7	63,2	78,8	84,1	86,8	102,3	106,3	115,0	125,1
		Pfs (kW)	27,5	33,7	42,4	44,4	47,0	47,8	62,4	65,8	66,9	82,3	84,0	87,9	92,6
		Pa (kW)	7,9	9,1	10,6	12,1	13,4	14,0	16,8	18,5	19,6	20,6	22,2	24,9	28,2

Pft: Total gross cooling capacity (sum of the power of the main circuit and the recovery circuit)

Total heating capacity with recovery circuit

50FC		020	028	037	040	045	047	052	058	062	070	074	086	093	
Nominal air flow	(m ³ /h)	5.100	6.500	8.500	8.750	9.000	9.000	12.000	12.500	12.500	15.500	15.500	16.000	16.000	
Outdoor temperature 6°C BH Indoor temperature 20°C	20% fresh air	Pct (kW)	29,7	35,8	44,3	47,9	53,0	55,7	68,3	73,5	76,2	87,8	91,9	100,9	110,2
		Pa (kW)	6,7	7,9	9,3	10,3	11,6	12,4	14,7	16,2	17,1	18,8	20,1	22,6	25,8
	40% fresh air	Pct (kW)	31,1	37,1	46,2	49,8	55,0	64,4	71,0	76,2	79,0	91,1	95,2	104,2	113,7
		Pa (kW)	6,4	7,5	8,9	9,9	11,1	11,9	14,1	15,5	16,4	18,0	19,3	21,7	24,7
	80% fresh air	Pct (kW)	32,8	39,0	47,8	52,3	57,7	60,4	74,8	80,1	83,0	95,6	99,8	108,9	118,7
		Pa (kW)	5,9	6,8	8,1	9,0	10,1	10,9	12,9	14,1	14,9	16,5	17,6	19,8	22,5

Pct: Total gross heating capacity (sum of the power of the main circuit and the recovery circuit)

OPTIONS FOR THE INDOOR UNIT (CONT.)

Auxiliary electrical heaters

Auxiliary electrical heaters, with two power stages and on/off control, for assembly and connection inside the unit.

■ Up to 3 values of total power available for each model:

50FC	020 to 047	052 to 062	070 to 093
RAF (Low)	12 kW	12 kW	18 kW
RAM (Nominal)	18 kW	18 kW	27 kW
RAS (High)	unavailable	27 kW	36 kW

■ Characteristics:

Total power (kW)	12	18	27	36
Stages power (kW)	6 + 6	9 + 9	9 + 18	18 + 18
Current (400 V / III ph) (A)	17,3	26,0	39,0	52,0
Power supply	400 V / III ph			

Auxiliary hot water coil

Auxiliary hot water coil, with three-way valve and proportional control, for assembly and connection inside the unit. This option always incorporates a freeze protection thermostat.

50FC		020	028	037	040	045	047	052	058	062	070	074	086	093
Air pressure drop (mm.w.c.)		2,4	3,5	3,5	3,6	4,3	4,3	3,4	3,6	3,6	3,5	3,7	3,7	3,7
Water 80/60°C and inlet air 20°C	Heating capacity (kW)	27,6	32,0	47,6	48,4	49,2	49,2	95,8	98,3	98,3	129,0	129,0	131,5	131,5
	Water flow (m³/h)	1,4	1,6	2,1	2,1	2,1	2,1	2,7	2,8	2,8	3,6	3,6	3,7	3,7
	Water pressure drop (m.w.c)	0,2	0,3	0,5	0,5	0,5	0,5	0,5	0,5	0,5	0,9	0,9	1,0	0,9
Water 90/70°C and inlet air 20°C	Heating capacity (kW)	34,2	39,8	58,7	59,8	90,8	90,8	118,5	121,5	121,5	158,7	158,7	161,9	161,9
	Water flow (m³/h)	1,7	2,0	2,6	2,6	2,6	2,6	3,4	3,4	3,4	4,5	4,5	4,6	4,6
	Water pressure drop (m.w.c)	0,3	0,4	0,7	0,7	0,8	0,8	0,7	0,7	0,7	1,3	1,4	1,4	1,4

Note: With droplet eliminator after the indoor air coil it is not possible to assemble the hot water coil.

Position of the hydraulic connections of the hot water coil

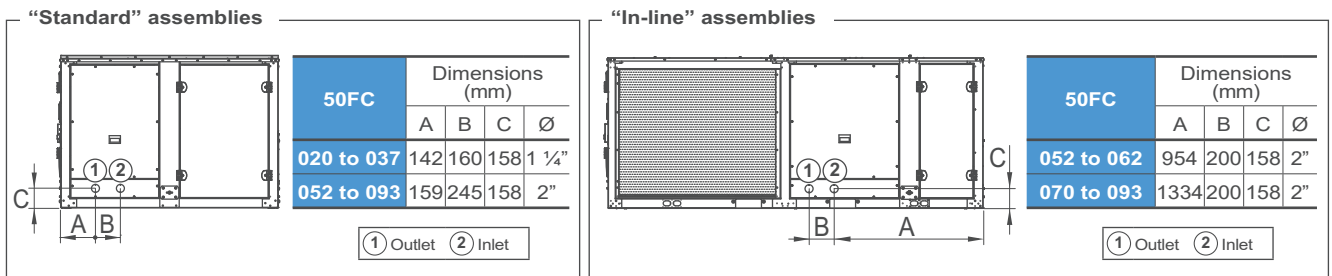

Note: The Input / Output connections of the coil are located inside the unit. The connection can be established via the unit base using flexible tubing or via the side panel. In the above diagrams, the position of the sheet metal precuts is shown on the side panel.

“Very low outdoor temperature” option (HAF)

Note: on units with the “Very low outdoor temperature” option, air supply only may be lateral (factory-configured).

- This anti-freeze safety incorporates:
 - Circulation pump.
 - Water temperature sensors located in the inlet and the outlet of the coil.
 - Electrical heating on the piping layout.

Important: this option is mandatory for an outdoor temperature lower than -20°C WB. Consult for percentages of glycol water above 20%.

■ Characteristics of the water circuit:

50FC		020 to 047	052 to 093
Circulation pump	Motor output (W)	90	140
	Max. absorbed current (A)	0,75	1,15

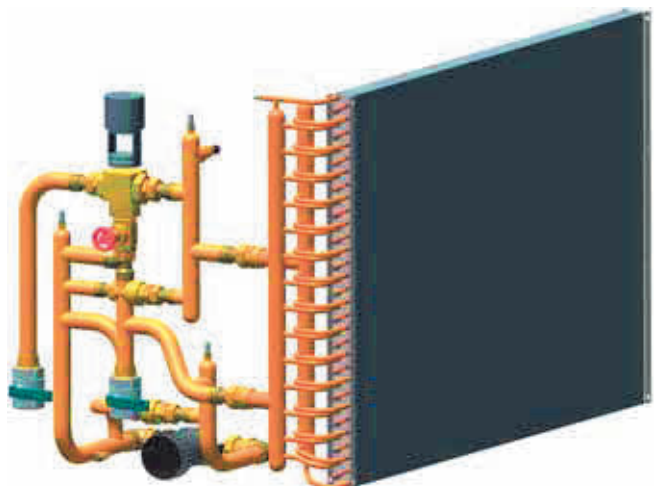

OPTIONS FOR THE INDOOR UNIT (CONT.)

Gas-fired condensing boiler with hot water coil

Gas-fired condensing boiler with modulating actuator, in accordance with the Gas Directive 2009/142/EC, mounted on the side of the unit.

EC certification: 0085CP0214.

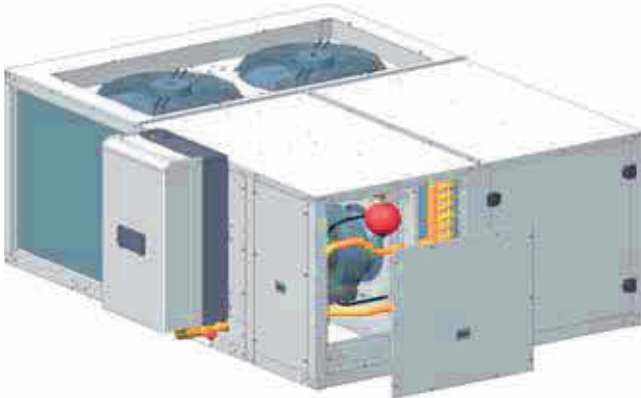

■ Up to 3 values of total power available for each model:

50FC	020 to 047	052 to 062	070 to 093
BBF (Low)	unavailable	Condexa PRO 50 (coming soon)	Condexa PRO 50 (coming soon)
BBM (Nominal)	Condexa PRO 40 (coming soon)	Condexa PRO 70	Condexa PRO 70
BBS (High)	Condexa PRO 70	Condexa PRO 100	Condexa PRO 100

■ The key features of the boiler are:

- Natural or propane gas boiler.
- Burner with premixing and modulation technology that allows outputs close to 109% (Hi performance).
- Heat exchanger made of stainless steel with a low carbon content.
- Proportional air / gas valve. Low NO_x emissions (class 5, according to standard EN 297).
- Condensate drain with siphon.
- Forced draught.
- Electronic ignition.
- Safety devices: safety thermostat, low water pressure safety switch, flowmeter, Delta-T control, smoke temperature sensor.
- NTC sensor for boiler water temperature regulation.
- Working temperature of water from -7°C to 100°C. Consult for percentages of glycol water above 20%.
- Electronic controller with microprocessor and Multifunction LCD display for boiler's control, configuration and diagnostics. Possibility of ModBus communication.
- The electronic control of the unit will only manage the boiler connection as heating support depending on the ambient conditions.

■ The boiler is connected to the hydraulic circuit of the auxiliary hot water coil. The water circuit, installed inside the unit, is composed of:

- Water coil.
- Circulation pump.
- Expansion vessel.
- Gate valves.
- Safety valve with a tare value of 4 bar.
- Automatic air bleeder valve.

■ Characteristics of the water circuit:

	50FC	020 to 047	052 to 093
Expansion vessel	Volume (l)	5	5
	Filling pressure (kg/cm ²)	1,5	1,5
Circulation pump	Motor output (W)	90	140
	Max. absorbed current (A)	0,75	1,15

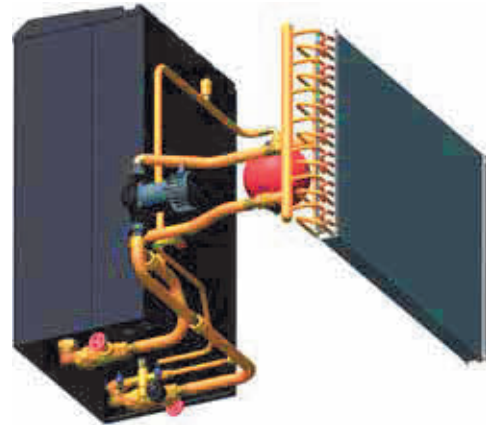

■ Type of gas used depending on the destination country:

Country	Category	Gas	Pressure (mbar)	Gas	Pressure (mbar)
Italy, Ireland, Great Britain, Portugal, Slovenia, Slovakia, Greece	I12H3+	G20	20	G30/G31	28-30/37
Spain	I12H3+	G20	18	G30/G31	28-30/37
Romania, Bulgaria, Turkey, Denmark, Estonia, Sweden, Norway, Latvia, Lithuania, Finland, Russia	I12H3B/P	G20	20	G30	30
Hungary	I12H3B/P	G20	25	G30	30
Poland	I12H3B/P	G20	25	G30	37
Croatia	I12H3B/P	G20	20	G30/G31	30
Holland	I12H3B/P	G25	25	G30	30
Czech Rep., Austria, Switzerland	I12H3B/P	G20	20	G30	50
Luxembourg	I12H3B/P	G20	20	G30	50
	I12E3P	G20	20	G31	37
Belgium	I2E(S)	G20/G25	20/25	--	--
	I3+	--	--	G30/G31	28-30/37
France	I12E+3+,	G20/G25	20/25	G30/G31	28-30/37
Malta, Cyprus, Iceland	I3B/P	--	--	G30	30
Germany	I12ELL3B/P	G20/G25	25	G30	50

OPTIONS FOR THE INDOOR UNIT (CONT.)

■ Technical characteristics of the boiler:

Model		Condexa PRO 40 (coming soon)	Condexa PRO 50 (coming soon)	Condexa PRO 70	Condexa PRO 100	
Type of equipment		B23 - B53 - B53P				
NOx Class (according to standard EN 297)		Val 5				
Boiler performance	Total thermal power (Hs)	kW		76/15	108/21,6	
	Total thermal power (Hi)	kW		68/14	97/19,4	
	Nominal power supplied to the water 100% (80°C - 60°C)	kW		66,7	95,2	
	Nominal power supplied to the water 100% (50°C - 30°C)	kW		73,5	105	
	Nominal power supplied to the water 100% (60°C - 40°C)	kW		71	101	
	Condensate hourly production 100% (50°C - 30°C) with G20	kg/h		8,5	12,3	
	Performance with nominal power (80°C - 60°C)	%		98,1	98,1	
	Performance with nominal power (50°C - 30°C)	%		108,1	108,2	
	Performance with nominal power Tm = 50°C (60°C - 40°C)	%		104,4	104,1	
	Performance with reduced load 30% (80°C - 60°C)	%		98,5	98,3	
	Performance with reduced load 30% (50°C - 30°C)	%		109	109	
	Performance with reduced load 30% Tm = 50°C (60°C - 40°C)	%		105,3	105	
	Losses in enclosure (Tm = 70°C)	%	0,1			
	Energy efficiency marking (Directive 92/42 EC)		★★★★			
Energy efficiency	Seasonal energy efficiency class in heating			A	A	
	Seasonal energy efficiency in heating	%		92,7	92,7	
Gas supply	Gas category	I12H3+				
	Natural Gas consumption (G20) (nominal / minimum)	m ³ /h		7,2/1,4	10,3/2,1	
Electrical data	Power supply	230 Vac - 50 Hz				
	Power input at 100%	W		77	203	
	Power input at 30%	W		30	31	
	Power input in stand-by	W		13	6	
	Ingress protection rating		IP X5D			
	Operating temperatures		de -15°C to +70°C			
Connections	Ø Gas supply			G1"	G1"	
	Ø Flue outlet	mm		DN80	DN110	
	Ø Condensate drain	mm		25	25	
Heating circuit	Control of heating temperature (min. / max.)	°C	20 / 80			
	Working pressure (max. / min.)	bar	6 / 0,7			

Location of the gas burner

50FC 020-028-037-040-045-047

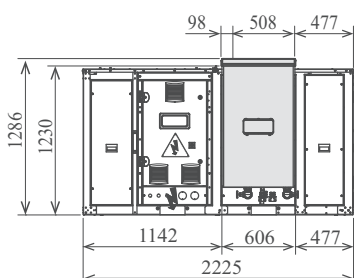
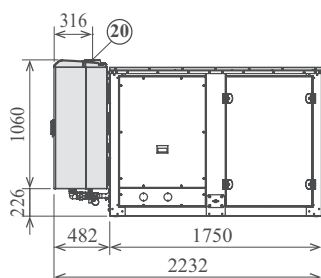
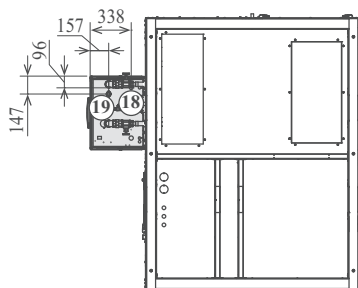

Legend

All dimensions are given in mm.

- 18 Boiler drainage Ø 25mm
Important: Siphon minimum height 300mm
- 19 Gas supply 1" M
- 20 Flue outlet (flue connection):
Condexa PRO 40 / 50 / 70: Ø 80mm

OPTIONS FOR THE INDOOR UNIT (CONT.)

50FC 052-058-062-070-074-086-093, "Standard"

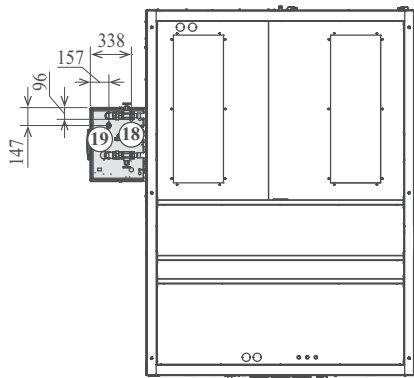

50FC	Dimensions (mm)		
	A	B	C
052 to 062	3.000	1.588	806
070 to 093	3.650	1.858	1.186

Legend

All dimensions are given in mm.

- (18) Boiler drainage Ø 25mm
Important: Siphon minimum height 300mm
- (19) Gas supply 1" M
- (20) Flue outlet (flue connection):
Condexa PRO 50 / 70: Ø 80mm
Condexa PRO 100: Ø 110 mm

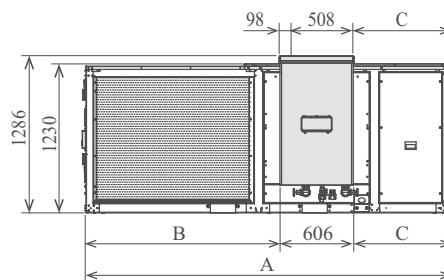
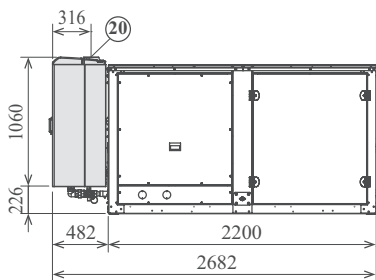

50FC 052-058-062-070-074-086-093, "In-line"

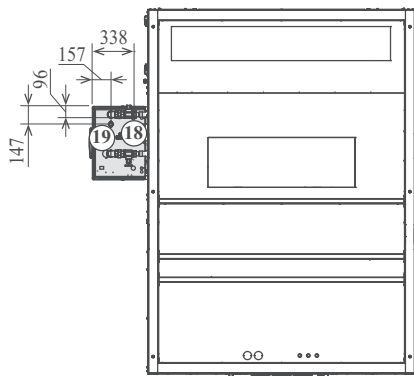

50FC	Dimensions (mm)		
	A	B	C
052 to 062	3.000	1.588	806
070 to 093	3.650	1.860	1.184

Legend

All dimensions are given in mm.

- (18) Boiler drainage Ø 25mm
Important: Siphon minimum height 300mm
- (19) Gas supply 1" M
- (20) Flue outlet (flue connection):
Condexa PRO 50 / 70: Ø 80mm
Condexa PRO 100: Ø 110 mm

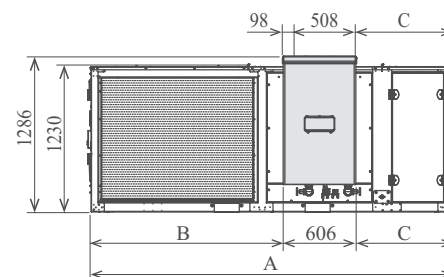
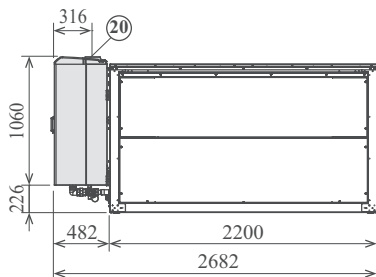

NOTES:

- Drawings are not contractually binding.
- Before designing an installation, consult the certified dimensional drawings, available on request.

IMPORTANT:

- The flue of the gas boiler is not supplied with the unit. Its design and installation is the responsibility of the installer and must comply with all the directives and regulations in force in the installation location.

OPTIONS FOR THE INDOOR UNIT (CONT.)

Warm air heater module with gas burner

Warm air heater module with gas burner with modulating actuator, in accordance with the Gas Directive 2009/142/EC, installed inside a pre-assembly roofcurb.

■ Up to 3 values of total power available for each model:

50FC	020 to 047	052 to 062	070 to 093
BAF (Low)	PCH020	unavailable	unavailable
BAM (Nominal)	PCH034	PCH065	PCH080
BAS (High)	PCH045	PCH080	PCH105

■ The key features of the boiler are:

- Natural or propane gas burner.
- Condensation boiler with premixing and modulation technology that allows outputs close to 109% (Hi performance).
- The premixed burner, in combination with the air/gas valve, ensures a "clean" combustion. Low NOx emissions (class 5, according to standard EN 297).
- The combustion chamber and the burner are entirely made of stainless steel.
- Electronic controller with microprocessor and multifunction LCD display, located inside the burner, for burner's control, configuration and diagnostics.
- The electronic control of the unit will only manage the burner connection as heating support depending on the ambient conditions.

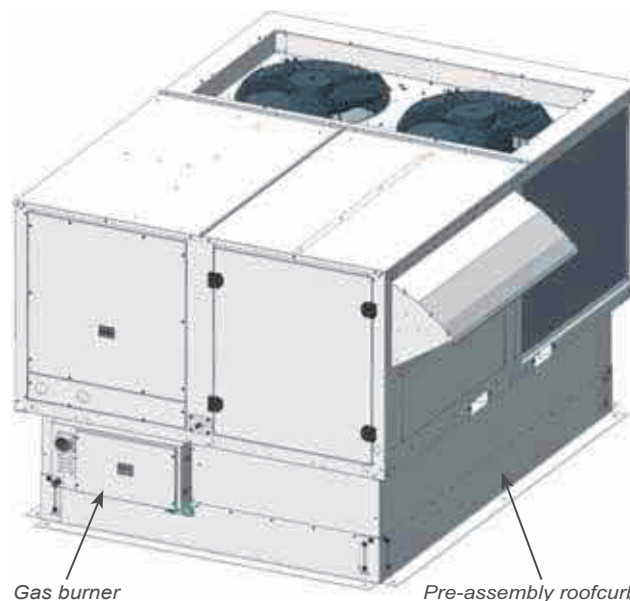

Note: It's recommended to use the clogged filter pressostat (optional) in units with gas burner.

Note: Drawings of roofcurb with gas burner can be consulted on pages 48 to 50.

Model		PCH020	PCH034	PCH045	PCH065	PCH080	PCH105							
Type of equipment		B23P - B53P - C13 - C43 - C53 - C63 - C83												
EC certification		PIN.		0694CP1457										
NOx Class		Val		5										
Heater performance	Range	Min.	Max	Min.	Max	Min.	Max	Min.	Max	Min.	Max	Min.	Max	
	Thermal output (Hi)	kW	4,75	19,00	7,60	34,85	8,50	44,00	12,40	65,00	16,40	82,00	18,00	100,00
	Useful thermal output	kW	4,97	18,18	8,13	33,56	9,00	42,40	13,40	62,93	17,77	80,03	19,63	97,15
	Hi performance (L.C.V.)	%	104,63	95,68	106,97	96,30	105,88	96,37	108,06	96,82	108,35	97,60	109,06	97,15
	Hs performance (H.C.V.)	%	94,26	86,20	96,37	86,76	95,39	87,36	97,36	87,22	97,62	87,93	98,25	87,52
	Flue losses with burner off (Hi)	%	0,4	4,3	0,6	3,7	0,5	3,7	0,2	3,2	0,3	2,4	0,2	2,8
	Flue losses with burner off (Hi)	%	<0,1											
	Losses in enclosure (1)		0%											
Max. condensation (2)	l/h	0,4		0,9		1,1		2,1		3,3		2,7		
Exhaust gases - Polluting emissions	Carbon monoxide - B1 - (0% of O2) (3)	ppm	< 5											
	Nitrogen oxides - NOx - (0% of O2) (4)		40 mg/kWh - 22,28 ppm		41 mg/kWh - 23,24 ppm		35 mg/kWh - 19,84 ppm		40 mg/kWh - 22,68 ppm		34 mg/kWh - 19,27 ppm		45 mg/kWh - 25,51 ppm	
	Available pressure at flue	Pa	80		90		100		120					
Electrical data	Power supply	230 Vac - 50 Hz single-phase												
	Power input	12	45	11	74	24	82	15	97	40	123	20	130	
	Power input in stand-by	<5												
	Ingress protection rating	IP X5D												
	Operating Temperatures	from -15°C to +40°C												
Connections	Ø gas connection	GAS		UNI/ISO 7/1- 3/4"										
	Ø intake/exhaust pipes	mm		80/80										

(1) Enclosure losses match those of the machine housing the PCH.

(2) Max. condensation produced acquired from testing 30%Qn.

(3) Value referenced to cat. H (G20)

(4) Weighted value to EN1020 ref. to class H (G20), referred to Hi (L.C.V.).

OPTIONS FOR THE INDOOR UNIT (CONT.)

■ Gas setting:

Gas type	Gas settings	PCH020		PCH034		PCH045		PCH065		PCH080		PCH105		
		min.	max.	min.	max.	min.	max.	min.	max.	min.	max.	min.	max.	
G20	Air supply pressure	mbar	20 [min 17-max 25]											
	Ø pilot nozzle	mm	0,7											
	Gas consumption (15°C-1013mbar)	m3/h	0,51	2,01	0,80	3,69	0,90	4,66	1,31	6,88	1,74	8,68	1,90	10,58
	Carbon dioxide - CO ₂ content	%	8,8	9,1	8,7	9,1	8,7	9,1	8,7	9,1	8,7	9,1	8,5	9,1
	Fumes temperature	°C	39	113	31	94	30	94	31	86	26,5	70	28	80
	Fume mass flow rate (max.)	kg/h	31		57		72		107		135		165	
	Gas butterfly valve	mm	5,8		7,4		7,5		11,0		12,2		15,8	
G25	Air supply pressure	mbar	25 [min 17-max 30] (20 for Germany)											
	Ø pilot nozzle	mm	0,7 (0,75 for Germany)											
	Gas consumption (15°C-1013mbar)	m3/h	0,59	2,34	0,93	4,29	1,05	5,41	1,53	8,00	2,02	10,1	2,21	12,30
	Carbon dioxide - CO ₂ content	%	8,8	9,0	8,6	9,0	8,8	8,9	8,8	9,2	8,6	8,9	8,8	9,0
	Fumes temperature	°C	39	113	31	94	30	94	31	86	26,5	70	28	80
	Fume mass flow rate (max.)	kg/h	--											
	Gas butterfly valve	mm	Not necessary											
G30	Air supply pressure	mbar	30 [min 25-max 35] - 50 [min 42,5-max 57,5]											
	Ø pilot nozzle	mm	0,51											
	Gas consumption (15°C-1013mbar)	m3/h	0,40	1,58	0,63	2,90	0,71	3,65	1,03	5,39	1,36	6,80	1,49	8,30
	Carbon dioxide - CO ₂ content	%	10,8	11,4	10,8	11,5	10,8	10,9	10,7	11,3	11,2	11,6	10,9	11,2
	Fumes temperature	°C	39	113	31	94	30	94	31	86	26,5	70	28	80
	Fume mass flow rate (max.)	kg/h	--											
	Gas butterfly valve	mm	3,7		5,0		5,2		6,5		7,0		9,3	
G31	Air supply pressure	mbar	30 [min 25-max 35] - 37 [min 25-max 45] - 50 [min 42,5-max 57,5]											
	Ø pilot nozzle	mm	0,51											
	Gas consumption (15°C-1013mbar)	m3/h	0,39	1,55	0,62	2,85	0,70	3,60	1,01	5,31	1,34	6,70	1,47	8,18
	Carbon dioxide - CO ₂ content	%	9,3	9,8	9,2	9,7	9,3	9,4	9,4	9,6	9,3	9,6	9,1	9,6
	Fumes temperature	°C	39	113	31	94	30	94	31	86	26,5	70	28	80
	Fume mass flow rate (max.)	kg/h	24		45		58		84		107		130	
	Gas butterfly valve	mm	3,7		5,0		5,2		6,5		7,0		9,3	

■ Type of gas used depending on the destination country:

Country	Category	Gas	Pressure (mbar)	Gas	Pressure (mbar)
Austria, Switzerland	I12H3B/P	G20	20	G30/G31	50
Belgium < 70kW	I2E(S)B,I3P	G20/G25	20/25	G31	37
Belgium > 70kW	I2E(R)B,I3P	G20/G25	20/25	G31	37
Germany	I12ELL3B/P	G20	20	G30/G31	50
Denmark, Finland, Greece, Sweden, Norway, Italy, Czech Republic, Estonia, Lithuania, Slovenia, Albania, Macedonia, Bulgaria, Romania, Croatia, Turkey	I12H3B/P	G20	20	G30/G31	30
Spain, United Kingdom, Ireland, Portugal, Slovakia	I12H3P	G20	20	G31	37
France	I12Esi3P	G20/G25	20/25	G31	37
Luxembourg	I12E3P	G20/G25	20	G31	37/50
Netherlands	I12L3B/P	G25	25	G30/G31	50
Hungary	I12HS3B/P	G20/G25.1	25	G30/G31	30
Cyprus, Malta	I3B/P	--	--	G30/G31	30
Latvia	I2H	G20	20		
Iceland	I3P	--	--	G31	37
Poland	I12E3B/P	G20/G2.350	20/13	G30/G31	37
Russia	I12H3B/P	G20	20	G30/G31	30

WEIGHT OVERVIEW

Weight of the various assemblies (kg)

50FC		020	028	037	040	045	047	052	058	062	070	074	086	093
B1 assembly		594	617	699	698	704	701	986	986	1.004	1.146	1.146	1.135	1.160
B2 assembly		609	632	718	718	718	720	1.018	1.024	1.037	1.181	1.181	1.190	1.195
B3 assembly		682	705	796	796	796	798	1.119	1.119	1.138	1.308	1.308	1.308	1.313
BX assembly		713	736	815	815	815	817	1.162	1.168	1.180	1.359	1.359	1.368	1.373
BP assembly		723	746	831	831	828	833	1.192	1.198	1.210	1.387	1.387	1.387	1.392
BA assembly		781	804	900	900	897	902	1.283	1.289	1.301	1.490	1.490	1.490	1.495
BT assembly		774	797	882	882	882	884	1.285	1.285	1.304	1.482	1.482	1.491	1.496
BB assembly		832	855	951	951	951	953	1.376	1.376	1.395	1.585	1.585	1.594	1.599
BW assembly	Machine	722	745	834	834	834	837	1.194	1.200	1.213	1.317	1.317	1.326	1.331
	Recovery module	254	254	254	254	254	254	348	348	348	454	454	454	454
	Total weight	976	999	1.088	1.088	1.088	1.091	1.542	1.548	1.561	1.771	1.771	1.780	1.785
R1 assembly		--	--	--	--	--	--	1.044	1.050	1.062	1.179	1.179	1.189	1.193
R2 assembly		--	--	--	--	--	--	1.082	1.088	1.101	1.216	1.216	1.225	1.230
RP assembly		--	--	--	--	--	--	1.252	1.258	1.270	1.405	1.405	1.414	1.419
RW assembly	Machine	--	--	--	--	--	--	1029	1035	1048	1358	1358	1367	1372
	Recovery module	--	--	--	--	--	--	719	719	719	454	454	454	454
	Total weight	--	--	--	--	--	--	1.749	1.755	1.767	1.812	1.812	1.822	1.826

Weight supplement from the main options (kg)

50FC		020	028	037	040	045	047	052	058	062	070	074	086	093	
Pre-assembly roofcurb (without gas burner)		145	145	145	145	145	145	205	205	205	237	237	237	237	
Pre-assembly roofcurb (with gas burner)	BAF (Low)	265	265	265	265	265	265	--	--	--	--	--	--	--	
	BAM (Nominal)	274	274	274	274	274	274	385	385	385	463	463	463	463	
	BAS (High)	284	284	284	284	284	284	411	411	411	483	483	483	483	
Electrical heaters	RAF (Low)	20	20	20	20	20	20	17	17	17	17	17	17	17	
	RAM (Nominal)	17	17	17	17	17	17	21	21	21	21	21	21	21	
	RAS (High)	--	--	21	21	21	21	25	25	25	25	25	25	25	
Hot water coil	Standard	Empty	33	33	37	37	37	37	51	51	51	58	58	58	58
		Service	40	40	46	46	46	46	67	67	67	78	78	78	78
	Very low outdoor T	Empty	41	41	45	45	45	45	71	71	71	78	78	78	78
		Service	49	49	55	55	55	55	89	89	89	100	100	100	100
Boiler + Hot water coil	Boiler		69	69	69	69	69	69	69	69	69	69	69	69	
	Water circuit	Empty	47	47	52	52	52	52	79	79	79	87	87	87	87
		Service	55	55	62	62	62	62	98	98	98	109	109	109	109
	Total service weight		124	124	131	131	131	131	167	167	167	178	178	178	178
Supply fan	Low pressure (F)		-7	-7	--	--	--	--	-21	-21	-21	-9	-9	-9	
	High pressure (S)		--	--	28	28	28	28	38	38	38	29	29	29	29
Droplet eliminator	Indoor coil		24	24	25	25	25	25	34	34	34	43	43	43	
	Fresh air intake		8	8	8	8	8	8	11	11	11	14	14	14	14